

INSTRUCTIONS FOR CANDIDATES

1. Total Number of Questions-100. Each Question is of three marks.
2. One mark will be deducted for every wrong answer.
3. No mark will be deducted for un-attempted questions.
4. Do not write on the Question Paper or make any mark on it.

Q1-3. Read the following passage carefully and answer the questions given below it:-

In spring, polar bear mothers emerge from dens with three months old cubs. The mother bear has fasted for as long as eight months but that does not stop the young from demanding full access to her remaining reserves. If there are triplets, the most persistent stands to gain an extra meal at the expense of others. The smallest of the cubs forfeits many meals to stronger siblings. Females are protective of their cubs but tend to ignore family rivalry over food. In 21 years of photographing polar bears, I have only once seen the smallest of triplets survive till autumn.

- Q1. Female polar bears give birth during
- (a) Spring
 - (b) Summer
 - (c) Autumn
 - (d) Winter
- Q2. Mother bear
- (a) Takes sides over cubs
 - (b) Lets the cubs fend for themselves
 - (c) Feeds only their favourites
 - (d) Sees that all cubs get an equal share
- Q3. With reference to the passage, the following assumptions have been made:-
- I. Polar bears fast as long as eight months due to non availability of prey.
 - II. Polar bears always give birth to triplets.
- Which of the assumptions given above is/ are true?
- (a) I only
 - (b) II only
 - (c) Both I and II
 - (d) Neither I nor II

Q4-9 Select the most appropriate word from the options against each number:-

As home entertainment, television is rapidly becoming more (4) than any other form. A news broadcast becomes more immediate when people (5) actually see the scene (6) question and the movement of the figures. Films could be viewed in the (7) of the home and a variety of shows are also available. One of the advantages of travel programmes is the (8) of faraway places which many viewers would not (9) see.

- Q4. (a) interesting (b) popular (c) powerful (d) purposeful
- Q5. (a) could (b) would (c) might (d) shall
- Q6. (a) of (b) with (c) as (d) in
- Q7. (a) surroundings (b) assistance (c) comfort (d) privilege
- Q8. (a) glimpses (b) image (c) portrait (d) picture
- Q9. (a) possible (b) rather (c) else (d) otherwise

Q10-13. Choose the word which is nearest in meaning to the given word:-

- Q10. Intransigent
- (a) Authoritative
 - (b) Impersonal
 - (c) Strenuous
 - (d) Unbending
- Q11. Intimidate
- (a) Mislead
 - (b) Misplace
 - (c) Frighten
 - (d) Demoralise
- Q12. Sporadic
- (a) Epidemic
 - (b) Whirling
 - (c) Occasional
 - (d) Stagnant
- Q13. Genesis
- (a) Style
 - (b) Beginning
 - (c) Movement
 - (d) Relevant

Q14-17. Choose the word which is nearly opposite in meaning to the given word:-

- Q14. Malevolent
 (a) Kindly (b) Vacuous (c) Ambivalent (d) Primitive
- Q15. Purgatory
 (a) Reward (b) Celestial (c) Flawless (d) Proximity
- Q16. Clemency
 (a) Corporal (b) Intolerance (c) Compromise (d) Sensibility
- Q17. Cajole
 (a) Nestle (b) Secede (c) Bully (d) Moisten

Q18-21. Choose the word that best defines the given phrases:-

- Q18. In weal and woe
 (a) By hook or crook (b) During illness
 (c) in prosperity and adversity (d) During the operation
- Q19. Globetrotters
 (a) People against global philosophy (b) People indulging in treachery
 (c) Intelligent minds (d) Travellers around the world
- Q20. A Curtain Lecture
 (a) To speak plainly (b) Vulgar Ideas
 (c) Private scolding of a husband by his wife (d) Hate others
- Q21. Square pegs in round holes
 (a) A genuinely helpful person (b) A Clever person
 (c) People in the wrong jobs (d) To be perplexed

Q22-25. Choose the correctly spelt word:-

- Q22. (a) Equanimity (b) Equannimity (c) Equanimmisty (d) Equinimity
- Q23. (a) Vetarinary (b) Vetenary (c) Veterinary (d) Vetniary
- Q24. (a) Konnoisseur (b) Conoisisseur (c) Connoisseur (d) Konoisseur
- Q25. (a) Munifisent (b) Muneficent (c) Munificent (d) Munificent

Q26-29. Which word or words explains the meaning of the following idioms:-

- Q26. In a jiffy
 (a) Outstanding (b) Suddenly (c) In a fix (d) Appropriate
- Q27. Upto the hilt
 (a) Completely (b) Upto the mark
 (c) Upto the final decision (d) None of these
- Q28. Man of Letters
 (a) Who writes too many letters (b) An important person
 (c) A politician (d) A literary person
- Q29. Sangfroid
 (a) Composure (b) Go on leave
 (c) Changed Suddenly (d) Make an attempt

Q30-65. Choose the most appropriate answer:-

- Q30. Which country among the following has been declared Ebola-free by WHO?
 (a) Sierra Leone (b) Liberia (c) Nigeria (d) Guinea
- Q31. How many Gold medals did India win in the Incheon Asian Games held in Oct 2014?
 (a) 10 (b) 11 (c) 12 (d) 8
- Q32. Who has been appointed as the new Finance Secretary of India?
 (a) Arvind Mayaram (b) Rajiv Mehrishi
 (c) Kaushik Basu (d) Dinesh Gupta

- Q33. Which among the following is India's first long range subsonic cruise missile?
 (a) Agni II (b) Prithvi (c) Dhanush (d) Nirbhay
- Q34. The branch of science that studies cells is called
 (a) Cytology (b) Entomology (c) Homoplastic (d) Hormonology
- Q35. How many Vice Presidents are elected at the start of its each regular session of UN General Assembly?
 (a) Nine (b) Fifteen (c) Two (d) Twenty one
- Q36. The highest civilian award of India 'Bharat Ratna' has been awarded to only two foreigners so far. One of them is Nelson Mandela. The other is
 (a) Marshal Tito (b) Mikhail Gorbachev
 (c) Khan Abdul Ghaffar Khan (d) Abdul Wali Khan
- Q37. Sir CV Raman was awarded Nobel Prize for his work connected with which of the following phenomenon of radiation?
 (a) Scattering (b) Diffraction (c) Interference (d) Polarisation
- Q38. In which city is the headquarters of Asian Development Bank located?
 (a) Manila (b) Singapore (c) Bangkok (d) Jakarta
- Q39. K-15 missile is
 (a) Submarine launched Ballistic Missile (SLBM)
 (b) Inter Continental Ballistic Missile (ICBM)
 (c) Medium Range Ballistic Missile (MRBM)
 (d) Short Range Ballistic Missile (SRBM)
- Q40. India agreed to UN Chief Ban Ki-Moon's offer to remain as a member of the advisory board of one of the following recently.
 (a) UNCCT (b) UNICEF (c) UNEP (d) UNCTAD
- Q41. Kaziranga National Park is famous for
 (a) One-horned Rhinos (b) Tigers
 (c) Swamp Dears (Barasingha) (d) Elephants
- Q42. Who was the first Indian to win an individual medal in Olympics?
 (a) Milkha Singh (b) PT Usha
 (c) Karnam Malleshwari (d) KD Jadhav
- Q43. Who among the following was the Congress President at Madras Session of 1927 when it boycotted the Simon Commission?
 (a) Maulana Abul Kalam Azad (b) MA Ansari
 (c) Lala Lajpat Rai (d) Subhash Chandra Bose
- Q44. Why did Kalinga prove to be a turning point in the life of Ashoka?
 (a) Ashoka annexed Kalinga
 (b) It was the starting point of the expansion of his empire
 (c) Ashoka became a zealous Buddhist
 (d) It enabled Mauryan Empire to reach its climax
- Q45. Which of the following wings was not part of the espionage system described by Kautilya?
 (a) Crime Branch (b) Special Branch
 (c) Political Branch (d) None of these
- Q46. Alauddin Khalji did not build
 (a) Siri Fort (b) Tomb of Jalaluddin
 (c) Hauz-i-Alai (d) Jamaat Khana Masjid
- Q47. Which of the following dynasties was ruling over North India at the time of Alexander's invasion?
 (a) Nanda (b) Maurya (c) Sunga (d) Kanva
- Q48. Which of the following Intercontinental Ballistic Missiles (ICBMs) is under development in India?
 (a) Agni-I (b) Agni-II (c) Agni-IV (d) Agni-VI

- Q49. Who among the following was adjudged as the Most Valuable Player of the 17th Asian Games held at Incheon, South Korea?
 (a) Mary Kom of India (b) Kosuke Hagino of Japan
 (c) Ning Zetao of China (d) None of these
- Q50. The opposition party status is accorded to a political party in the Lok Sabha only if it captures at least
 (a) 5% Seats (b) 10% Seats (c) 15% Seats (d) 20% Seats
- Q51. Who amongst the following is the author of the book 'A Bend in the River'?
 (a) Chetan Bhagat (b) VS Naipaul
 (c) Kiran Desai (d) Anita Desai
- Q52. 'Long Walk to Freedom' is a book written by
 (a) Sonia Gandhi (b) LK Advani
 (c) Nelson Mandela (d) Benazir Bhutto
- Q53. Which sports personality has been awarded the honorary rank of Group Captain by the IAF?
 (a) Kapil Dev (b) Sania Mirza
 (c) Saina Nehwal (d) Sachin Tendulkar
- Q54. A man travelled from a point A to B at the rate of 25 Kmph and walked back at the rate of 4 Kmph. If the whole journey took 5 hrs 48 minutes, the distance between A and B is
 (a) 30 Km (b) 24 Km (c) 20 Km (d) 51.6 Km
- Q55. A Train travelling at a uniform speed clears a platform 200 m long in 10 seconds and passes a telegraph post in 5 seconds. The speed of the train is
 (a) 36 km/h (b) 39 km/h (c) 72 km/h (d) 78 km/h
- Q56. The price of sugar increases by 20% due to the festive season. By what percentage should a family reduce the consumption of sugar so that there is no change in the expenditure?
 (a) 20% (b) $18\frac{1}{3}\%$ (c) $16\frac{2}{3}\%$ (d) $16\frac{1}{3}\%$
- Q57. A's salary is 20% lower than B's salary, which is 15% lower than C's salary. By how much percent is C's salary more than A's salary?
 (a) 44.05% (b) 45.05% (c) 46.05% (d) 47.05%
- Q58. The average weight of 5 men is increased by 2 Kg when one of the men whose weight is 60 Kg is replaced by a new man. The weight of the new man is
 (a) 50 Kg (b) 65 Kg (c) 68 Kg (d) 70 Kg
- Q59. A and B can do a piece of work in 18 days; B and C can do it in 24 days, A and C can do it in 36 days. In how many days B alone can finish the work?
 (a) 48 days (b) 45 days (c) $28\frac{4}{5}$ days (d) 144 days
- Q60. A, B and C can do a piece of work in 20, 30 and 60 days respectively. In how many days can A do the work if he is assisted by B and C on every third day?
 (a) 12 days (b) 15 days (c) 16 days (d) 18 days
- Q61. A man can row $9\frac{1}{3}$ Kmph in still water and finds that it takes him thrice as much time to row up than as to row down the same distance in the river. The speed of the current is
 (a) $3\frac{1}{3}$ Kmph (b) $3\frac{1}{9}$ Kmph (c) $4\frac{2}{3}$ Kmph (d) $4\frac{1}{3}$ Kmph
- Q62. The speed of a boat in still water is 10 Kmph. If it can travel 26 Km downstream and 14 Km upstream in the same time, the speed of the stream is
 (a) 2 Kmph (b) 2.5 Kmph (c) 3 Kmph (d) 4 Kmph
- Q63. If a sum becomes double in 16 years, how many times will it be in 8 years?
 (a) $1\frac{1}{2}$ times (b) $1\frac{1}{3}$ times (c) $1\frac{3}{4}$ times (d) $1\frac{1}{4}$ times

Q64. In how many years will a sum of Rs 800 at 10% per annum compounded semi-annually become Rs 926.10?

- (a) $1\frac{1}{3}$ (b) $1\frac{1}{2}$ (c) $2\frac{1}{3}$ (d) $2\frac{1}{2}$

Q65. A sells 2 TV sets, one at a loss of 15% and another at a profit of 15%. Find the loss/gain percentage in the overall transaction?

- (a) 2.25% (b) 3% (c) 4% (d) No profit, no loss

Q 66-70. Each of these questions given below contains three elements. These elements may or may not have some inter-linkage. Each group of elements may fit into one of these diagrams at (a), (b), (c) or (d). You have to indicate the group of elements which correctly fits into the diagrams.

Q66. Which of the following diagrams indicates the best relation between Doctors, Human Beings and Married People?

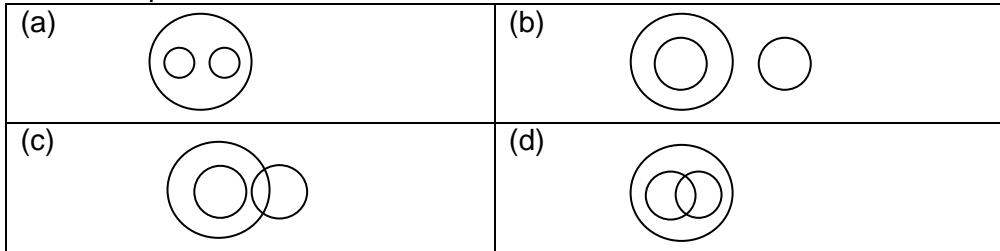

Q67. Which of the following diagrams indicates the best relation between Man, Worker and Garden?

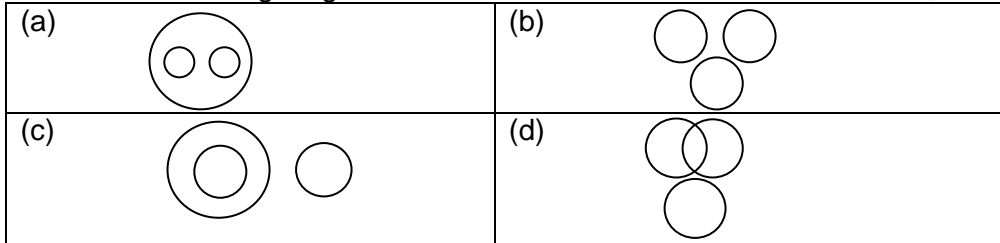

Q68. Which of the following diagrams indicates the best relation between Males, Cousins and Nephews?

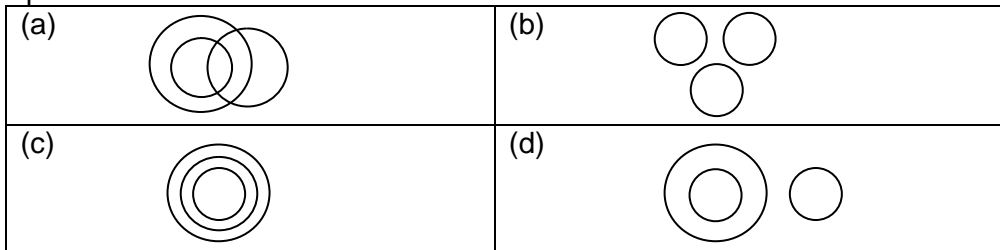

Q69. Which of the following diagrams indicates the best relation between Children, Naughty, and Studious?

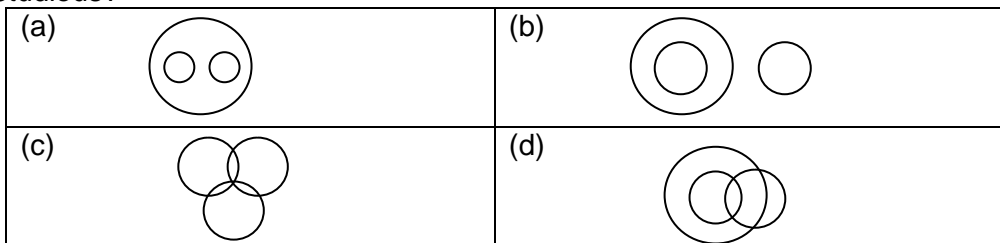

Q70. Which of the following diagrams indicates the best relation between Thief, Criminal and Police?

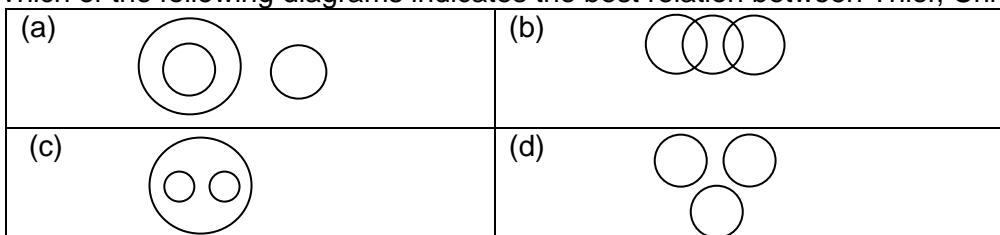

Q71-75 In each of the following questions find out the alternative which will replace the question mark.

Q71. Loath : Coercion :: ? : ?

- (a) Detest : Caressing (b) Irritate : Caressing
(c) Irate : Antagonism (d) Reluctant : Persuasion

Q72. Trilogy : Novel :: ? : ?

- (a) Rice : Husk (b) Milk : Cream
(c) Serial : Episode (d) Gun : Cartridge

Q73. Wife : Marriage :: ? : ?

- (a) Bank : Money (b) Nationality : Citizenship
(c) Service : Qualification (d) Attendance : Register

Q74. East : Orient :: ? : ?

- (a) North : Polar (b) North : Tropic
(c) South : Capricorn (d) West : Occident

Q75. Ignominy : Disloyalty :: ? : ?

- (a) Death : Victory (b) Martyr : Man
(c) Fame : Heroism (d) Destruction : Victory

Q76-80. In each of the following questions, four words have been given out of which three are alike in some manner, while the fourth one is different. Choose the word which is different from the rest.

Q76. (a) Aravalli hills (b) Shivalik hills (c) Mole hills (d) Satpura hills

Q77. (a) Beaver (b) Alpaca (c) Walrus (d) Koala

Q78. (a) Othello (b) King Lear (c) Oliver Twist (d) Macbeth

Q79. (a) Nimitz (b) Yamamoto (c) Nelson (d) Montgomery

Q80. (a) Blaze (b) Glint (c) Simmer (d) Shimmer

Q81-85. In each of the following questions, select a figure from amongst the four alternatives, which when placed in the blank space of figure (X) would complete the pattern.

Q81.

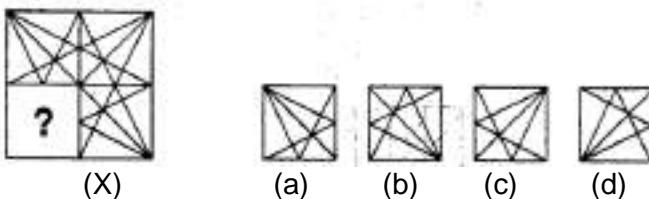

Q82.

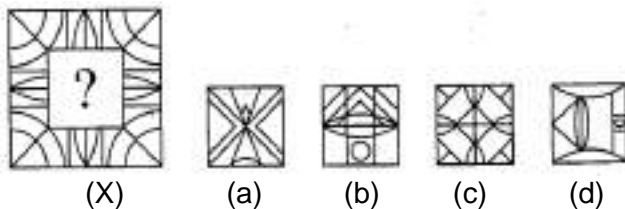

Q83.

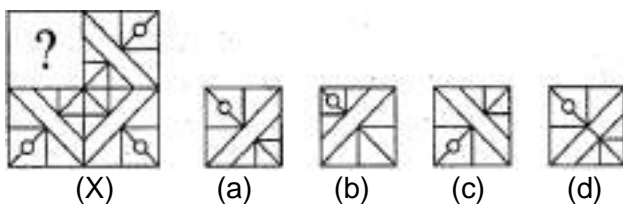

Q84.

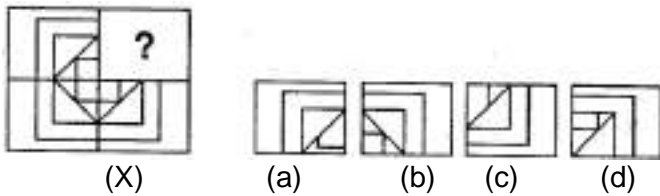

Q85.

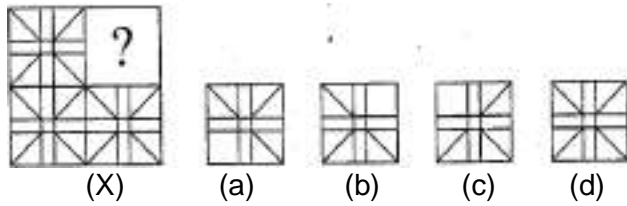

Q86-90. Each of the following questions consists of five figures marked 1,2,3,4 and 5 called the Problem Figures followed by four other figures marked a, b, c and d called the Answer Figures. Select a figure from amongst the Answer Figures which will continue the same series as established by the five Problem Figures.

Q86.



Q87.

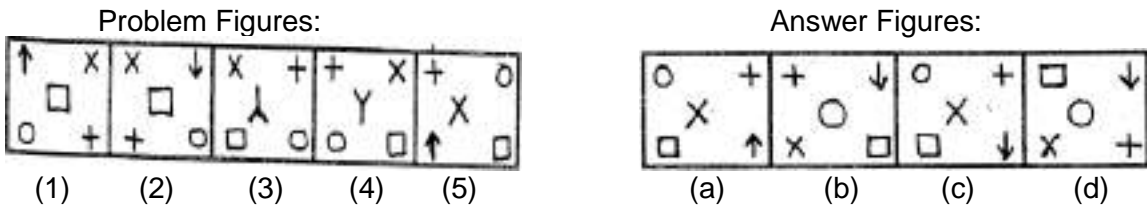

Q88.

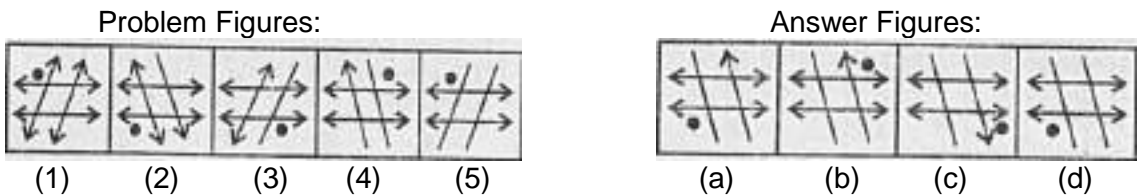

Q89.

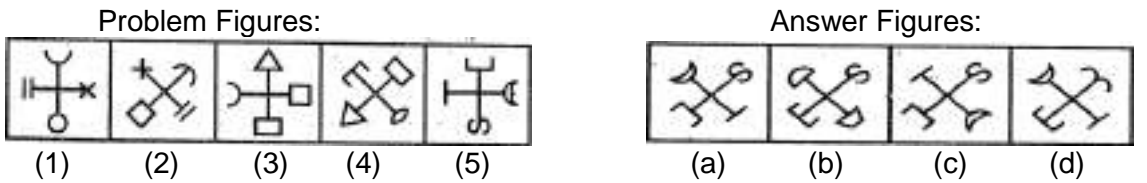

Q90.

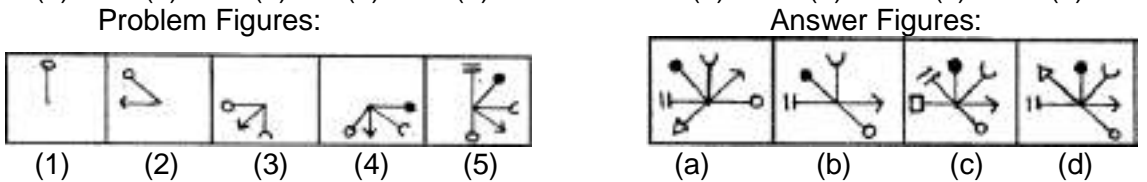

Q91-95. Each of the following questions consists of two sets of figures. Figures 1, 2, 3 and 4 constitute the Problem Set while figures a, b, c and d constitute the Answer Set. There is a definite relationship between figures (1) and (2). Establish a similar relationship between figures (3) and (4) by selecting a suitable figure from the Answer set that would replace the question mark (?) in fig.(4).

Q91.

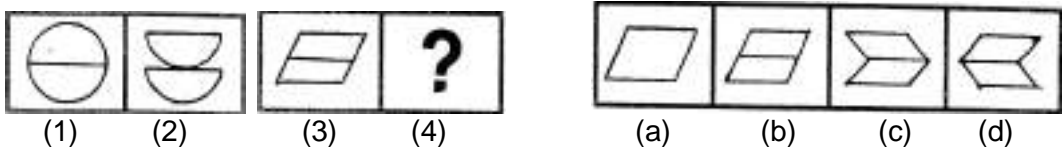

Q92.

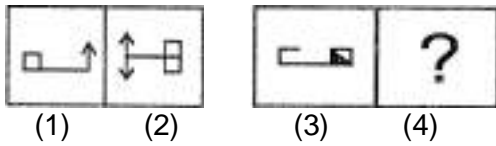

Q93.

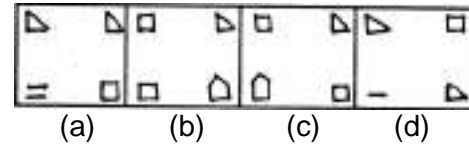
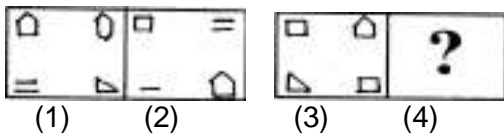

Q94.

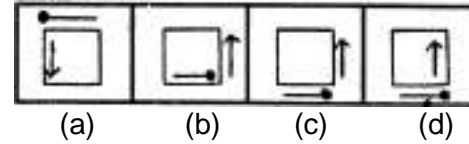

Q95.

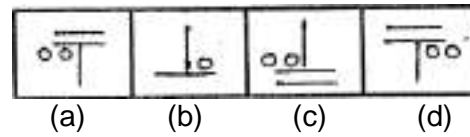
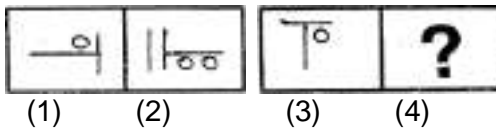

Q96-100. In each problem, out of the four figures marked (a) (b) (c) and (d) three are similar in a certain manner. However, one figure is not like the other three. Choose the figure which is different from the rest.

Q96.

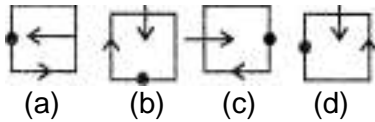

Q97.

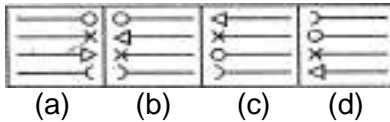

Q98.

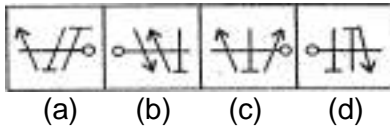

Q99.

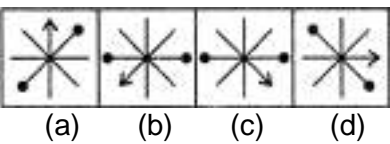

Q100.

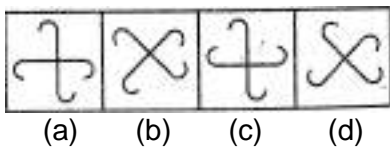

TIME ALLOTTED – 2HRS

INSTRUCTIONS FOR CANDIDATES

1. Total Number of Questions-100. Each Question is of three marks.
2. One mark will be deducted for every wrong answer.
3. No mark will be deducted for un-attempted questions.
4. Do not write on the Question Paper or make any mark on it.

Q1-4. Which word or words explains the meaning of the following idioms:-

- Q1. In a jiffy
 (a) Outstanding (b) Suddenly (c) In a fix (d) Appropriate
- Q2. Upto the hilt
 (a) Completely (b) Upto the mark
 (c) Upto the final decision (d) None of these
- Q3. Man of Letters
 (a) Who writes too many letters (b) An important person
 (c) A politician (d) A literary person
- Q4. Sangfroid
 (a) Composure (b) Go on leave
 (c) Changed Suddenly (d) Make an attempt

Q5-10 Select the most appropriate word from the options against each number:-

As home entertainment, television is rapidly becoming more (5) than any other form. A news broadcast becomes more immediate when people (6) actually see the scene (7) question and the movement of the figures. Films could be viewed in the (8) of the home and a variety of shows are also available. One of the advantages of travel programmes is the (9) of faraway places which many viewers would not (10) see.

- Q5. (a) interesting (b) popular (c) powerful (d) purposeful
- Q6. (a) could (b) would (c) might (d) shall
- Q7. (a) of (b) with (c) as (d) in
- Q8. (a) surroundings (b) assistance (c) comfort (d) privilege
- Q9. (a) glimpses (b) image (c) portrait (d) picture
- Q10. (a) possible (b) rather (c) else (d) otherwise

Q11-14. Choose the word which is nearest in meaning to the given word:-

- Q11. Sporadic
 (a) Epidemic (b) Whirling (c) Occasional (d) Stagnant
- Q12. Genesis
 (a) Style (b) Beginning (c) Movement (d) Relevant
- Q13. Intransigent
 (a) Authoritative (b) Impersonal (c) Strenuous (d) Unbending
- Q14. Intimidate
 (a) Mislead (b) Misplace (c) Frighten (d) Demoralise

Q15-18. Choose the word which is nearly opposite in meaning to the given word:-

- Q15. Clemency
 (a) Corporal (b) Intolerance (c) Compromise (d) Sensibility
- Q16. Cajole
 (a) Nestle (b) Secede (c) Bully (d) Moisten

Q17. Malevolent
 (a) Kindly (b) Vacuous (c) Ambivalent (d) Primitive

Q18. Purgatory
 (a) Reward (b) Celestial (c) Flawless (d) Proximity

Q19-21. Read the following passage carefully and answer the questions given below it:-

In spring, polar bear mothers emerge from dens with three months old cubs. The mother bear has fasted for as long as eight months but that does not stop the young from demanding full access to her remaining reserves. If there are triplets, the most persistent stands to gain an extra meal at the expense of others. The smallest of the cubs forfeits many meals to stronger siblings. Females are protective of their cubs but tend to ignore family rivalry over food. In 21 years of photographing polar bears, I have only once seen the smallest of triplets survive till autumn.

Q19. With reference to the passage, the following assumptions have been made:-

I. Polar bears fast as long as eight months due to non availability of prey.

II. Polar bears always give birth to triplets.

Which of the assumptions given above is/ are true?

(a) I only (b) II only (c) Both I and II (d) Neither I nor II

Q20. Female polar bears give birth during

- (a) Spring
 (b) Summer
 (c) Autumn
 (d) Winter

Q21. Mother bear

- (a) Takes sides over cubs
 (b) Lets the cubs fend for themselves
 (c) Feeds only their favourites
 (d) Sees that all cubs get an equal share

Q22-25. Choose the word that best defines the given phrases:-

Q22. A Curtain Lecture

- (a) To speak plainly (b) Vulgar Ideas
 (c) Private scolding of a husband by his wife (d) Hate others

Q23. Square pegs in round holes

- (a) A genuinely helpful person (b) A Clever person
 (c) People in the wrong jobs (d) To be perplexed

Q24. In weal and woe

- (a) By hook or crook (b) During illness
 (c) in prosperity and adversity (d) During the operation

Q25. Globetrotters

- (a) People against global philosophy (b) People indulging in treachery
 (c) Intelligent minds (d) Travellers around the world

Q26-29. Choose the correctly spelt word:-

Q26. (a) Konnoisseur (b) Conoisisseur (c) Connoisseur (d) Konoisseur

Q27. (a) Munifisent (b) Muneficent (c) Munificent (d) Munificent

Q28. (a) Equanimity (b) Equannimity (c) Equanimmisty (d) Equinimity

Q29. (a) Vetarinary (b) Vetenary (c) Veterinary (d) Vetniary

Q30-65. Choose the most appropriate answer:-

Q30. A, B and C can do a piece of work in 20, 30 and 60 days respectively. In how many days can A do the work if he is assisted by B and C on every third day?

- (a) 12 days (b) 15 days (c) 16 days (d) 18 days

- Q31. A man can row $9\frac{1}{3}$ Kmph in still water and finds that it takes him thrice as much time to row up than as to row down the same distance in the river. The speed of the current is
 (a) $3\frac{1}{3}$ Kmph (b) $3\frac{1}{9}$ Kmph (c) $4\frac{2}{3}$ Kmph (d) $4\frac{1}{3}$ Kmph
- Q32. The speed of a boat in still water is 10 Kmph. If it can travel 26 Km downstream and 14 Km upstream in the same time, the speed of the stream is
 (a) 2 Kmph (b) 2.5 Kmph (c) 3 Kmph (d) 4 Kmph
- Q33. If a sum becomes double in 16 years, how many times will it be in 8 years?
 (a) $1\frac{1}{2}$ times (b) $1\frac{1}{3}$ times (c) $1\frac{3}{4}$ times (d) $1\frac{1}{4}$ times
- Q34. In how many years will a sum of Rs 800 at 10% per annum compounded semi-annually become Rs 926.10?
 (a) $1\frac{1}{3}$ (b) $1\frac{1}{2}$ (c) $2\frac{1}{3}$ (d) $2\frac{1}{2}$
- Q35. A sells 2 TV sets, one at a loss of 15% and another at a profit of 15%. Find the loss/gain percentage in the overall transaction?
 (a) 2.25% (b) 3% (c) 4% (d) No profit, no loss
- Q36. A man travelled from a point A to B at the rate of 25 Kmph and walked back at the rate of 4 Kmph. If the whole journey took 5 hrs 48 minutes, the distance between A and B is
 (a) 30 Km (b) 24 Km (c) 20 Km (d) 51.6 Km
- Q37. A Train travelling at a uniform speed clears a platform 200 m long in 10 seconds and passes a telegraph post in 5 seconds. The speed of the train is
 (a) 36 km/h (b) 39 km/h (c) 72 km/h (d) 78 km/h
- Q38. The price of sugar increases by 20% due to the festive season. By what percentage should a family reduce the consumption of sugar so that there is no change in the expenditure?
 (a) 20% (b) $18\frac{1}{3}\%$ (c) $16\frac{2}{3}\%$ (d) $16\frac{1}{3}\%$
- Q39. A's salary is 20% lower than B's salary, which is 15% lower than C's salary. By how much percent is C's salary more than A's salary?
 (a) 44.05% (b) 45.05% (c) 46.05% (d) 47.05%
- Q40. The average weight of 5 men is increased by 2 Kg when one of the men whose weight is 60 Kg is replaced by a new man. The weight of the new man is
 (a) 50 Kg (b) 65 Kg (c) 68 Kg (d) 70 Kg
- Q41. A and B can do a piece of work in 18 days; B and C can do it in 24 days, A and C can do it in 36 days. In how many days B alone can finish the work?
 (a) 48 days (b) 45 days (c) $28\frac{4}{5}$ days (d) 144 days
- Q42. The opposition party status is accorded to a political party in the Lok Sabha only if it captures at least
 (a) 5% Seats (b) 10% Seats (c) 15% Seats (d) 20% Seats
- Q43. Who amongst the following is the author of the book 'A Bend in the River'?
 (a) Chetan Bhagat (b) VS Naipaul
 (c) Kiran Desai (d) Anita Desai
- Q44. 'Long Walk to Freedom' is a book written by
 (a) Sonia Gandhi (b) LK Advani
 (c) Nelson Mandela (d) Benazir Bhutto
- Q45. Which sports personality has been awarded the honorary rank of Group Captain by the IAF?
 (a) Kapil Dev (b) Sania Mirza
 (c) Saina Nehwal (d) Sachin Tendulkar

- Q46. Which country among the following has been declared Ebola-free by WHO?
 (a) Sierra Leone (b) Liberia (c) Nigeria (d) Guinea
- Q47. How many Gold medals did India win in the Incheon Asian Games held in Oct 2014?
 (a) 10 (b) 11 (c) 12 (d) 8
- Q48. Who has been appointed as the new Finance Secretary of India?
 (a) Arvind Mayaram (b) Rajiv Mehrishi
 (c) Kaushik Basu (d) Dinesh Gupta
- Q49. Which among the following is India's first long range subsonic cruise missile?
 (a) Agni II (b) Prithvi (c) Dhanush (d) Nirbhay
- Q50. The branch of science that studies cells is called
 (a) Cytology (b) Entomology (c) Homoplastic (d) Hormonology
- Q51. How many Vice Presidents are elected at the start of its each regular session of UN General Assembly?
 (a) Nine (b) Fifteen (c) Two (d) Twenty one
- Q52. The highest civilian award of India 'Bharat Ratna' has been awarded to only two foreigners so far. One of them is Nelson Mandela. The other is
 (a) Marshal Tito (b) Mikhail Gorbachev
 (c) Khan Abdul Ghaffar Khan (d) Abdul Wali Khan
- Q53. Sir CV Raman was awarded Nobel Prize for his work connected with which of the following phenomenon of radiation?
 (a) Scattering (b) Diffraction (c) Interference (d) Polarisation
- Q54. In which city is headquarters of Asian Development Bank located?
 (a) Manila (b) Singapore (c) Bangkok (d) Jakarta
- Q55. K-15 missile is
 (a) Submarine launched Ballistic Missile (SLBM)
 (b) Inter Continental Ballistic Missile (ICBM)
 (c) Medium Range Ballistic Missile (MRBM)
 (d) Short Range Ballistic Missile (SRBM)
- Q56. India agreed to UN Chief Ban Ki-Moon's offer to remain as a member of the advisory board of one of the following recently.
 (a) UNCCT (b) UNICEF (c) UNEP (d) UNCTAD
- Q57. Kaziranga National Park is famous for
 (a) One-horned Rhinos (b) Tigers
 (c) Swamp Dears (Barasingha) (d) Elephants
- Q58. Who was the first Indian to win an individual medal in Olympics?
 (a) Milkha Singh (b) PT Usha
 (c) Karnam Malleshwari (d) KD Jadhav
- Q59. Who among the following was the Congress President at Madras Session of 1927 when it boycotted the Simon Commission?
 (a) Maulana Abul Kalam Azad (b) MA Ansari
 (c) Lala Lajpat Rai (d) Subhash Chandra Bose
- Q60. Why did Kalinga prove to be a turning point in the life of Ashoka?
 (a) Ashoka annexed Kalinga
 (b) It was the starting point of the expansion of his empire
 (c) Ashoka became a zealous Buddhist
 (d) It enabled Mauryan Empire to reach its climax
- Q61. Which of the following wings was not part of the espionage system described by Kautilya?
 (a) Crime Branch (b) Special Branch
 (c) Political Branch (d) None of these

- Q62. Alauddin Khalji did not build
 (a) Siri Fort (b) Tomb of Jalaluddin
 (c) Hauz-i-Alai (d) Jamaat Khana Masjid
- Q63. Which of the following dynasties was ruling over North India at the time of Alexander's invasion?
 (a) Nanda (b) Maurya (c) Sunga (d) Kanva
- Q64. Which of the following Intercontinental Ballistic Missiles (ICBMs) is under development in India?
 (a) Agni-I (b) Agni-II (c) Agni-IV (d) Agni-VI
- Q65. Who among the following was adjudged as the Most Valuable Player of the 17th Asian Games held at Incheon, South Korea?
 (a) Mary Kom of India (b) Kosuke Hagino of Japan
 (c) Ning Zetao of China (d) None of these

Q66-70 In each of the following questions find out the alternative which will replace the question mark.

- Q66. East : Orient :: ??
 (a) North : Polar (b) North : Tropic
 (c) South : Capricorn (d) West : Occident
- Q67. Ignominy : Disloyalty :: ??
 (a) Death : Victory (b) Martyr : Man
 (c) Fame : Heroism (d) Destruction : Victory
- Q68. Loath : Coercion :: ??
 (a) Detest : Caressing (b) Irritate : Caressing
 (c) Irate : Antagonism (d) Reluctant : Persuasion
- Q69. Trilogy : Novel :: ??
 (a) Rice : Husk (b) Milk : Cream
 (c) Serial : Episode (d) Gun : Cartridge
- Q70. Wife : Marriage :: ??
 (a) Bank : Money (b) Nationality : Citizenship
 (c) Service : Qualification (d) Attendance : Register

Q 71-75. Each of these questions given below contains three elements. These elements may or may not have some inter-linkage. Each group of elements may fit into one of these diagrams at (a), (b), (c) or (d). You have to indicate the group of elements which correctly fits into the diagrams.

- Q71. Which of the following diagrams indicates the best relation between Doctors, Human Beings and Married People?

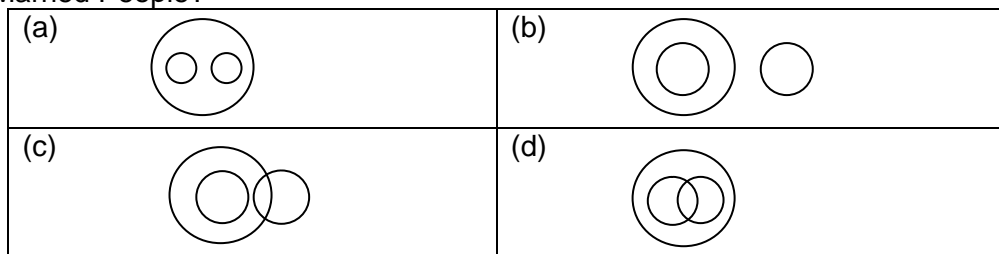

- Q72. Which of the following diagrams indicates the best relation between Children, Naughty, and Studious?

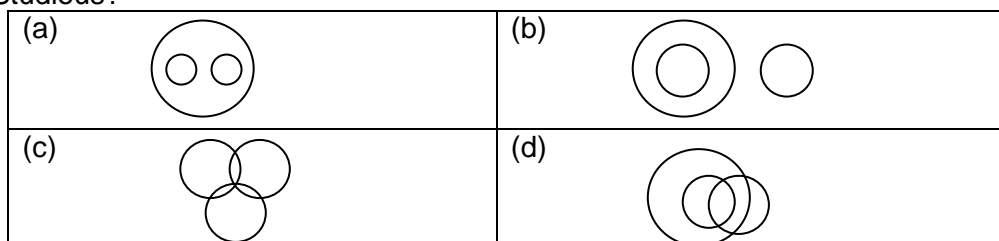

Q73. Which of the following diagrams indicates the best relation between Thief, Criminal and Police?

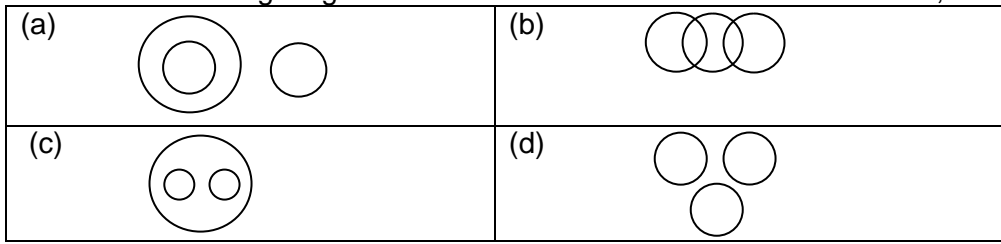

Q74. Which of the following diagrams indicates the best relation between Man, Worker and Garden?

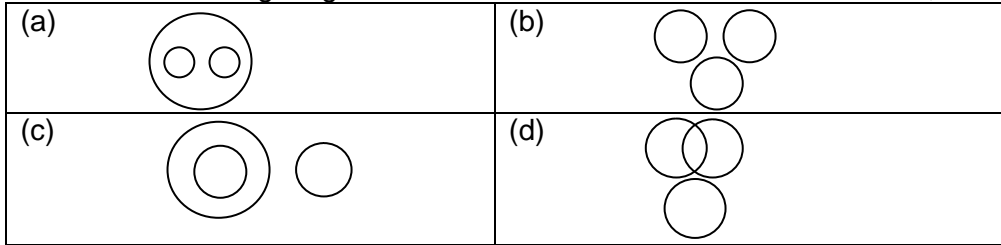

Q75. Which of the following diagrams indicates the best relation between Males, Cousins and Nephews?

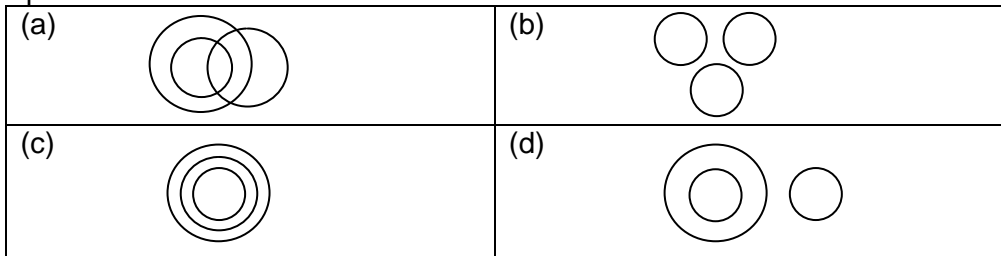

Q76-80. In each of the following questions, select a figure from amongst the four alternatives, which when placed in the blank space of figure (X) would complete the pattern.

Q76.

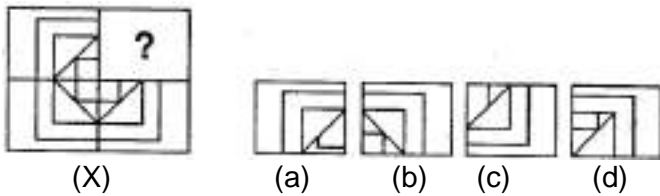

Q77.

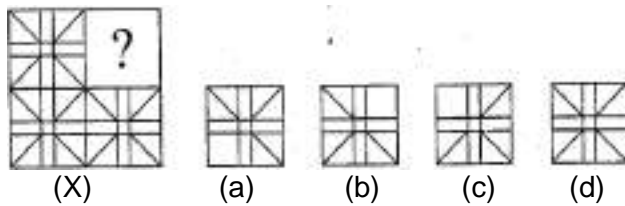

Q78.

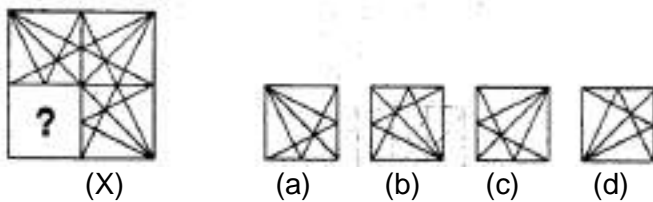

Q79.

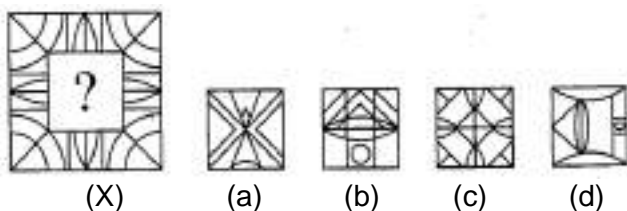

Q80.

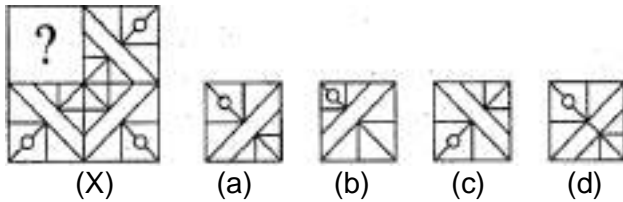

Q81-85. Each of the following questions consists of five figures marked 1,2,3,4 and 5 called the **Problem Figures** followed by four other figures marked a, b, c and d called the **Answer Figures**. Select a figure from amongst the **Answer Figures** which will continue the same series as established by the five **Problem Figures**.

Q81.

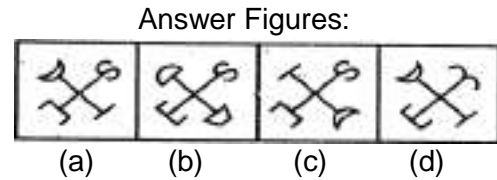
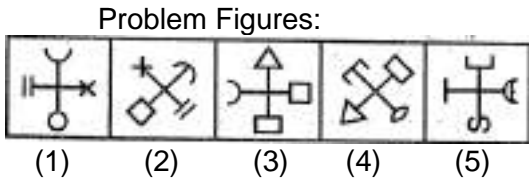

Q82.

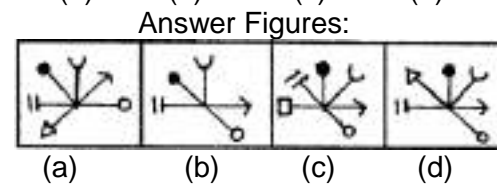
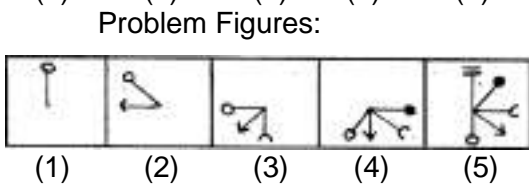

Q83.

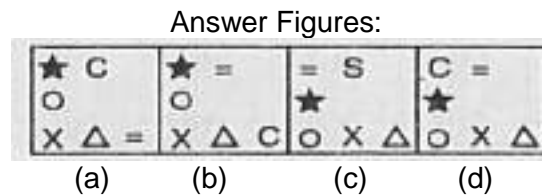
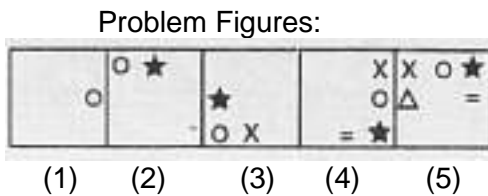

Q84.

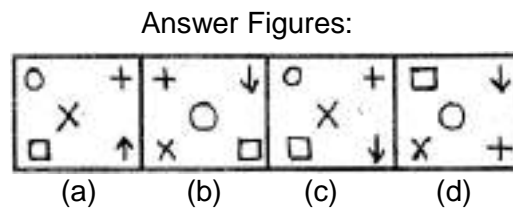
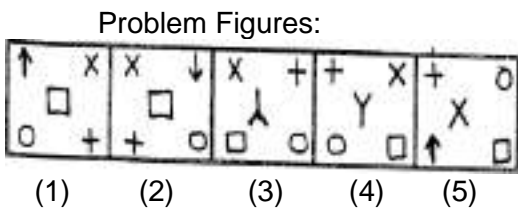

Q85.

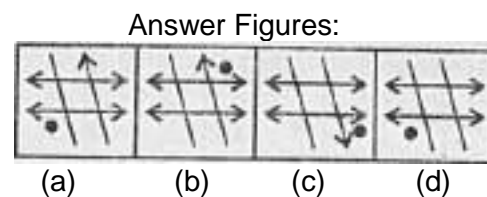
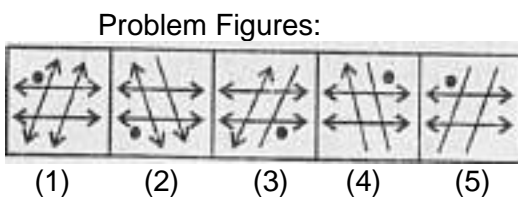

Q86-90. In each of the following questions, four words have been given out of which three are alike in some manner, while the fourth one is different. Choose the word which is different from the rest.

Q86. (a) Othello (b) King Lear (c) Oliver Twist (d) Macbeth

Q87. (a) Nimitz (b) Yamamoto (c) Nelson (d) Montgomery

Q88. (a) Blaze (b) Glint (c) Simmer (d) Shimmer

Q89. (a) Aravalli hills (b) Shivalik hills (c) Mole hills (d) Satpura hills

Q90. (a) Beaver (b) Alpaca (c) Walrus (d) Koala

Q91-95. In each problem, out of the four figures marked (a) (b) (c) and (d) three are similar in a certain manner. However, one figure is not like the other three. Choose the figure which is different from the rest.

Q91.

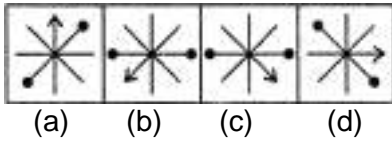

Q92.

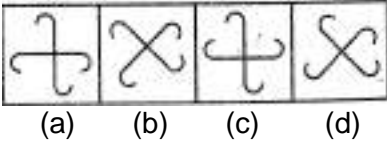

Q93.

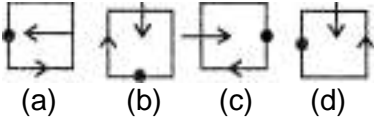

Q94.

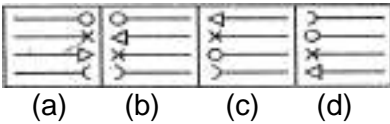

Q95.

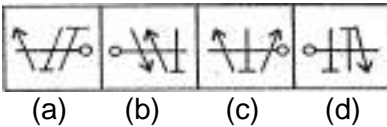

Q96-100. Each of the following questions consists of two sets of figures. Figures 1, 2, 3 and 4 constitute the Problem Set while figures a, b, c and d constitute the Answer Set. There is a definite relationship between figures (1) and (2). Establish a similar relationship between figures (3) and (4) by selecting a suitable figure from the Answer set that would replace the question mark (?) in fig.(4).

Q96.

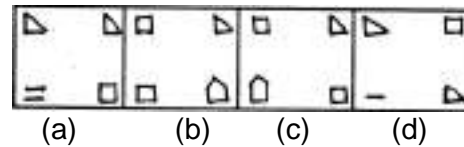
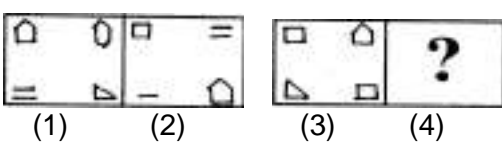

Q97.

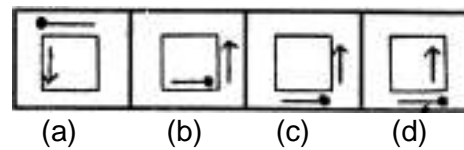
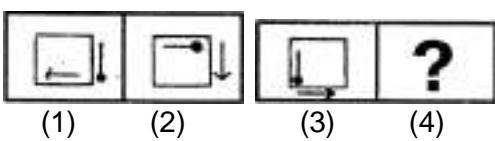

Q98.

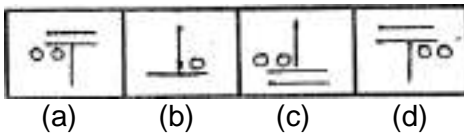
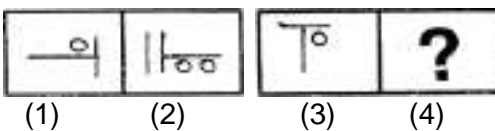

Q99.

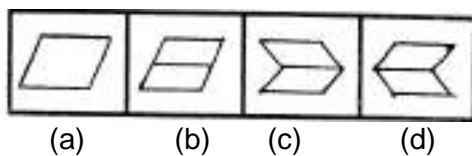
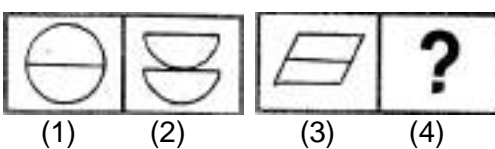

Q100.

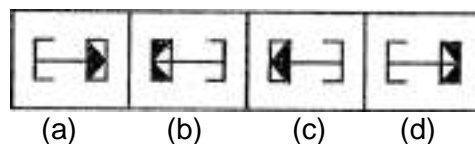
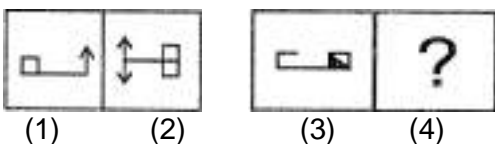

INSTRUCTIONS FOR CANDIDATES

1. Total No Of Questions-100. Each Question is of three marks.
2. One mark will be deducted for every wrong answer.
3. No mark will be deducted for un-attempted questions.
4. Do not write on the Question Paper or make any mark on it.

Q1-3. Read the following passage carefully and answer the questions given below it:-

Recently, a newspaper article mourned the total disappearance of the common house sparrow. This was a comment on the city's perceptible move towards edging out the flora and fauna of the city. In the rapid urbanization, multi-storied apartments grew and large scale felling of trees became necessary. Last week, however, seven pairs of these sparrows were spotted in a suburb. Possibly the greenery of this place has created a new habitat for these birds which like their proximity to human beings, and have made a comeback. A systematic development of trees and shrubs all over the city could woo the absentee house sparrow to our midst.

- Q1. In the passage the term "urbanisation" has been used to refer to
- (a) the destruction of the greenery in the city
 - (b) construction of concrete structures on a large scale
 - (c) a change over from the rural life to the city life
 - (d) the movement of people from villages to cities
- Q2. The phrase "absentee house sparrow" refers to
- (a) the sparrow that makes infrequent visits
 - (b) the sparrow that has forgotten its habitat
 - (c) the sparrow that has gone away from the urban areas
 - (d) the sparrow that has become extinct
- Q3. According to the passage, the birds have made a comeback to the suburb because they
- (a) have been hunted down by the village people
 - (b) Love to be amidst human beings
 - (c) get food only where human beings live
 - (d) they have been deliberately brought back by biologists

Q4-9 Select the most appropriate word from the options against each number:-

Watermelons ..(4).. to India by the 4th century A.D. Sushruta, the great Indian physician,(5)...wrote Sushruta Samhit, mentions that watermelons were grown ..(6).. the banks of the river Indus.(7)...are also mentioned in ancient books. Sushruta calls it as Kalinda or Kalinga (hence Kalingad in Marathi). It was...(8)..to China in the 10th or 11th century and ...(9)... it is grown throughout the tropics.

- Q4. (a) came (b) go (c) arrived (d) started
- Q5. (a) did (b) when (c) certainly (d) who
- Q6. (a) above (b) outside (c) from (d) along
- Q7. (a) it (b) they (c) some (d) that
- Q8. (a) took (b) gave (c) taken (d) take
- Q9. (a) also (b) though (c) now (d) tomorrow

Q10-13. Choose the word which is nearest in meaning to the given word:-

- Q10. Embellish
- (a) Employ (b) Arrange
 - (c) Decorate (d) Design
- Q11. Damp Squib
- (a) Insignificant happening (b) An old technique
 - (c) Unsuccessful attempt (d) Short, shrill cry

- Q12. Sagacious
 (a) Stupid (b) Truthful (c) Lustful (d) Discerning
- Q13. Pontificate
 (a) To speak authoritatively (b) To raise to higher office
 (c) To act clumsily (d) To constitute

Q14-17. Choose the word which is nearly opposite in meaning to the given word:-

- Q14. Parsimonious
 (a) Generous (b) Selfish (c) Religious (d) Hereditary
- Q15. Vindicate
 (a) Censure (b) Favour (c) Indicate (d) Eradicate
- Q16. Sporadic
 (a) Rare (b) Frequent (c) Sharp (d) Coordinated
- Q17. Exonerate
 (a) Reject (b) Contract (c) Accuse (d) Admit

Q18-21. Choose the word that best defines the given phrases:-

- Q18. Cloak and dagger
 (a) To fight to a finish (b) To get into unexpected trouble
 (c) To end the hostility (d) Like a spy
- Q19. To be at the end of one's tether
 (a) To feel offended (b) To draw moral attention
 (c) To have no resources left (d) To think deeply
- Q20. All agog
 (a) Work helplessly (b) Lose consciousness
 (c) In a state of excitement (d) Fall flat
- Q21. Espirit de Corps
 (a) Bravery (b) Loyalty (c) Subordination (d) Unity

Q22-25. Choose the correctly spelt word:-

- Q22. (a) Omminous (b) Omineous (c) Ominous (d) Omenous
- Q23. (a) Hindrance (b) Hinderance (c) Hindrence (d) Hinderence
- Q24. (a) Perjery (b) Perjury (c) Purjury (d) Perjary
- Q25. (a) Reminiscene (b) Reminiscence (c) Reminicence (d) Remeniscence

Q26-29. Which word or words explains the meaning of the following idioms:-

- Q26. A blue stocking
 (a) Stocking which is blue in colour (b) A clean cheat
 (c) An unreliable person (d) a woman having literary tastes and learning
- Q27. Yeoman's service
 (a) lip-service (b) to serve like a slave
 (c) to play god father (d) efficient or useful help
- Q28. Lay bare
 (a) Expose (b) Take off all clothes
 (c) Destroy (d) Exploit
- Q29. A wolf in sheep's clothing
 (a) A hypocrite (b) A wolf in woolen clothes
 (c) A coward (d) A proud man

Q30-65. Choose the most appropriate answer:-

- Q30. The national emblem, viz four lions standing back to back is an adaptation from which of the following:-
 (a) Sarnath lions (b) Gir lions
 (c) Khajurao (d) Ajanta caves
- Q31. Who among the following is not a recipient of the 'Bharatiya Jnanpith' Award?
 (a) Ashapura Devi (b) MF Hussain
 (c) Raghupati Sahay (d) VK Gokak
- Q32. Global 500 awards are given for outstanding achievement in which of the following fields?
 (a) Population Control (b) Elimination of illiteracy
 (c) Campaigning against AIDS (d) Protection of environment
- Q33. Pulitzer Prize is awarded for the outstanding work in the field of
 (a) Science and Technology (b) Environmental Studies
 (c) Literature and Journalism (d) International Understanding
- Q34. Who was the founder of Nanda dynasty?
 (a) Bimbisara (b) Mahapadma Nanda
 (c) Ajatasatru (d) Dhana Nanda
- Q35. Which of the following books is written by Arnold Toynbee?
 (a) Mankind and Mother Earth (b) Tom Sawyer
 (c) The Future of Freedom (d) The Moon's Last Sigh
- Q36. The presidency of the UN Security Council rotates among the Council Members
 (a) Every 6 months (b) Every year
 (c) Every 3 months (d) Every month
- Q37. Who were the contemporaries of the Gupta Kings in the south?
 (a) Chola (b) Rashtrakutas
 (c) Satavahanas (d) Vakatakas
- Q38. Who was the person behind conversion of East India Company from a trading company into a regional power?
 (a) Lord Warren Hastings (b) Lord Clive
 (c) Lord Dalhousie (d) Lord Wellesley
- Q39. Who inscribed the name of Khalifa of Baghdad on his coins?
 (a) Ala-ud-din Khilji (b) Iltutmish
 (c) Qutub-ud-din Aibak (d) Balban
- Q40. Who among the following Sultans of Delhi assumed the title, 'Sikandar-i-Sani'?
 (a) Balban (b) Ala-ud-din Khilji
 (c) Muhammad-bin-Tughlaq (d) Sikander Lodhi
- Q41. UN General Assembly recently declared 21st June as
 (a) International Youth Day (b) International Literacy Day
 (c) International Day of Yoga (d) International Day of Peace
- Q42. The member countries of NAFTA are
 (a) USA, Canada and Mexico (b) Canada and Mexico
 (c) USA and Canada (d) Argentina and Brazil
- Q43. Sandeep Sejwal won the Bronze medal in 2014 Asian Games in which of the following events?
 (a) 200m backstroke (b) 200m freestyle
 (c) 50m breaststroke (d) 50m butterfly
- Q44. The Indian space programme began in
 (a) 1961 (b) 1962 (c) 1965 (d) 1969

- Q45. 'Bachpan Bachao Andolan (BBA)', an organisation to protect the rights of children was founded by
 (a) Amir Khan (b) Kailash Satyarthi
 (c) Om Prakash Gurjar (d) Santa Sinha
- Q46. Mangalyan, Mars Orbiter Mission (MOM) was launched in
 (a) Jan 2013 (b) Oct 2012 (c) Oct 2013 (d) Nov 2013
- Q47. "Ruhr of India" known for its rich coal deposits is in the State of
 (a) Uttar Pradesh (b) Jharkhand (c) West Bengal (d) Bihar
- Q48. Which of the following Subsonic missiles, test fired in October 2014 is considered India's answer to America's Tomahawk missile
 (a) Brahmos Mk-2 (b) Prahaar (c) Nirbhay (d) Agni-V
- Q49. Who among the following won the World Billiards Championship held in England in October 2014?
 (a) Peter Gilchrist (b) Pankaj Advani
 (c) Saurav Kothari (d) None of these
- Q50. Which country will host the XXXI Olympic Games in 2016?
 (a) Rio de Janeiro, Brazil (b) Chicago, USA
 (c) Tokyo, Japan (d) Doha, Qatar
- Q51. The book, "A China Passage" was written by
 (a) MJ Akbar (b) Jagmohan
 (c) Anees Jung (d) John Kenneth Galbraith
- Q52. A can do a piece of work in 20 days and B in 25 days. They work together for 5 days and then B goes away. In how many days will A finish the work?
 (a) 11 days (b) 9 days (c) 20 days (d) 21 days
- Q53. Two train A & B each 66 meters long run parallel to each other in the same direction. Their speeds are 50 Km/h and 30 Km/h respectively. In what time A will completely pass B.
 (a) 28 Sec (b) 28.46 Sec (c) 53.46 Sec (d) 23.76 Sec
- Q54. A train 77.5 m in length is running at the rate of 65 Km/h. Find the time taken by the train to pass the man walking in the same direction as the train @ 3 Km/h.
 (a) 2.5 Sec (b) 4.5 Sec (c) 6.5 Sec (d) 8 Sec
- Q55. Ram can row $7\frac{1}{2}$ Km/h in still water. If in a river running at 1.5 Km/h, it takes him 50 minutes to row to a place and back, how far is the place?
 (a) 3.5 Km (b) 3 Km (c) 4.5 Km (d) 5 Km
- Q56. A motorboat with speed 15 Km/h in still water goes 30 Km downstream and comes back. It covers the distance in 4 hours and 30 minutes. The speed of the stream in Km/h is?
 (a) 4 (b) 5 (c) 6 (d) 10
- Q57. Zinc and copper are melted together in the ratio 9:11. What is the weight of the melted mixture, if 28.8 kg of zinc has been consumed in it?
 (a) 58 Kg (b) 60 Kg (c) 64 Kg (d) 70 Kg
- Q58. A sells his goods 20% cheaper than B and 20% dearer than C. How much percentage is C's goods cheaper / dearer than B.
 (a) 33.33% (b) 50% (c) 45.85% (d) None of these
- Q59. The average of 6 observations is 12. If the 7th observation is included, the average is reduced by 1. What will be the 7th observation?
 (a) 4 (b) 5 (c) 6 (d) 7
- Q60. If the incomes of Ram & Shyam are in the ratio of 3:4 and their expenditures in the ratio of 4:5, find the ratio of their savings, given that Shyam saves a third of his income.
 (a) 10:15 (b) 13:20 (c) 15:20 (d) 13:15

- Q61. The sum of ages of 4 children born at the interval of 2 years is 52. What is the age of the oldest child?
 (a) 10 years (b) 12 years (c) 14 years (d) 16 years
- Q62. A certain sum under compound interest, compounded annually, amounts to Rs. 5500/- in 5 years and Rs. 6050/- in 6 years. What is the rate of interest?
 (a) $12\frac{1}{2}\%$ (b) 15% (c) 20% (d) 10%
- Q63. Rs. 800 becomes Rs. 956 in 3 years at a certain rate of simple interest. If the rate of interest is increased by 4%, what amount will Rs. 800 becomes in 3 years?
 (a) Rs 1020.80 (b) Rs 1025 (c) Rs 1052 (d) Rs 1000
- Q64. A sum of money lent out at simple interest amounts to Rs 720 after 2 years and to Rs 1020 after a further period of 5 years. The sum is
 (a) Rs 500 (b) Rs 600 (c) Rs 700 (d) Rs 750
- Q65. Present age of X and Y are in the ratio 7:5 respectively. Four years hence, the ratio of their ages will become 11:9 respectively. What is the present age of Y?
 (a) 1 year (b) 7 year (c) 5 year (d) None of these

Q 66-70. Each of these questions given below contains three elements. These elements may or may not have some inter-linkage. Each group of elements may fit into one of these diagrams at (a), (b), (c) or (d). You have to indicate the group of elements which correctly fits into the diagrams.

- Q66. Which of the following diagrams indicates the best relation between Biology, Zoology and Physics?

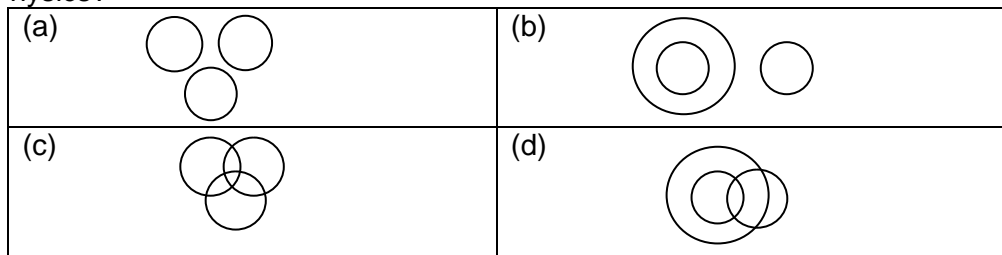

- Q67. Which of the following diagrams indicates the best relation between Stamp, Pen and Chalk?

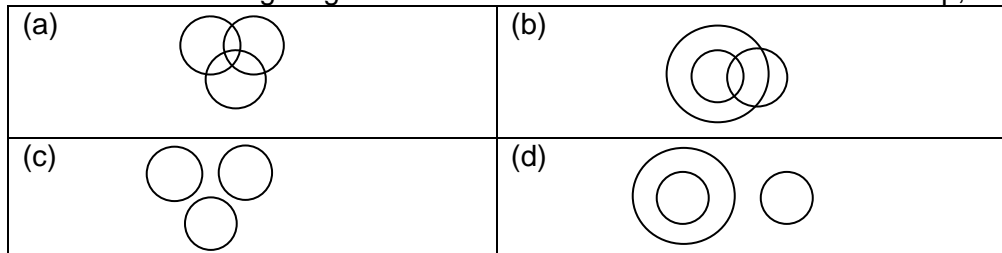

- Q68. Which of the following diagrams indicates the best relation between Singers, Athletes and Girls?

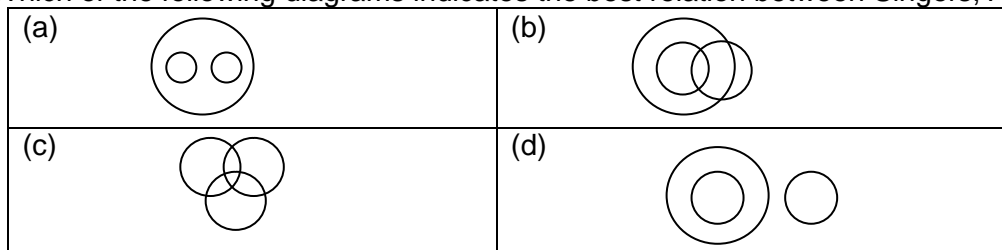

- Q69. Which of the following diagrams indicates the best relation between Teachers, Women and Doctors?

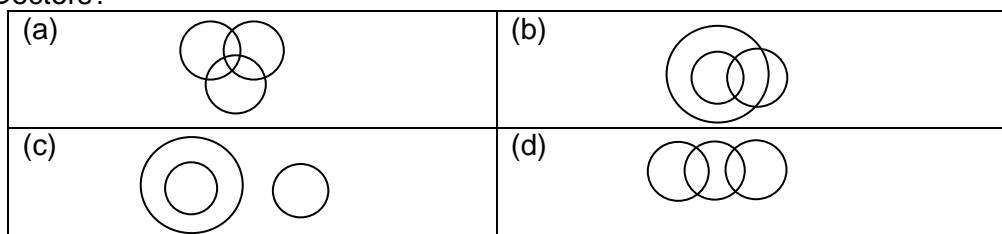

Q70. Which of the following diagrams indicates the best relation between Clothes, Flowers and White?



Q71-75 In each of the following questions find out the alternative which will replace the question mark.

Q71. Cerebrum : Brain :: ??

- | | |
|-----------------------|------------------------|
| (a) Aorta : Hand | (b) Ligament : Blood |
| (c) Ventricle : Heart | (d) Country : Universe |

Q72. Monument : Cenotaph :: ??

- | | |
|------------------------|----------------------|
| (a) Orifice : Opening | (b) Guide : Follower |
| (c) Protect : Protocol | (d) Sponsor : Cleave |

Q73. Meadow : Sheep :: ??

- | | |
|-------------------------|----------------------|
| (a) Stable : Horse | (b) Hay : Insect |
| (c) Grass : Grasshopper | (d) Pasture : Cattle |

Q74. Sadist : Injury :: ??

- | | |
|------------------------------|---------------------|
| (a) Opportunist : Generosity | (b) Priest : Church |
| (c) Dentist : Teeth | (d) Thief : Robbery |

Q75. Lecherous : Carnal :: ??

- | | |
|---------------------|----------------------|
| (a) Virile : Feeble | (b) Diatribe : Abuse |
| (c) Impede : Begin | (d) Sunder : Link |

Q76-80 In each of the following questions, four words have been given out of which three are alike in some manner, while the fourth one is different. Choose the word which is different from the rest.

Q76. (a) Niger (b) Suez (c) Mississippi (d) Colorado

Q77. (a) Bang (b) Hiss (c) Whistle (d) Wink

Q78. (a) Gold (b) Silver (c) Bronze (d) Iron

Q79. (a) Mendicant (b) Ascetic (c) Pious (d) Hermit

Q80. (a) Bardoli (b) Bhadravati (c) Porbandar (d) Champaran

Q81-85. In each of the following questions, select a figure from amongst the four alternatives, which when placed in the blank space of figure (X) would complete the pattern.

Q81.

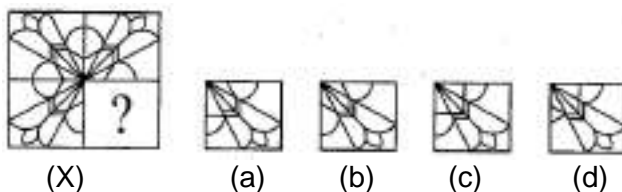

Q82.

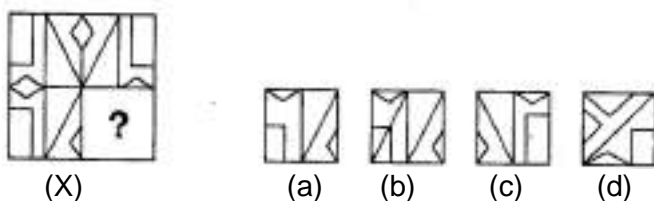

Q83.

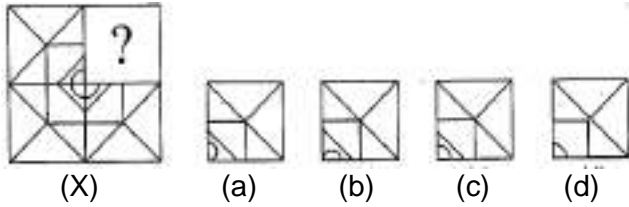

Q84.

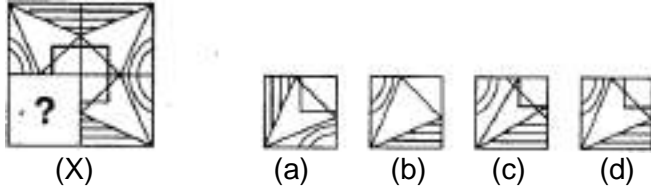

Q85.

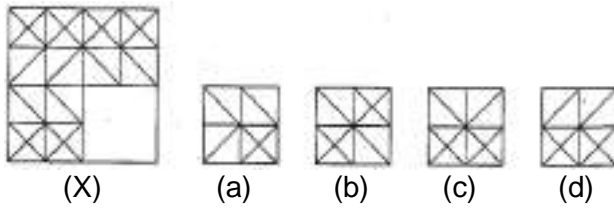

Q86-90. Each of the following questions consists of five figures marked 1,2,3,4 and 5 called the **Problem Figures** followed by four other figures marked a, b, c and d called the **Answer Figures**. Select a figure from amongst the Answer Figures which will continue the same series as established by the five Problem Figures.

Q86.

Problem Figures:

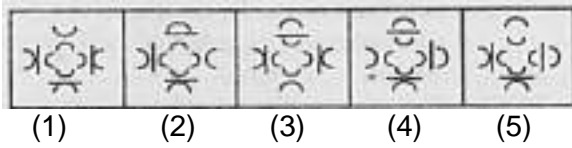

Answer Figures:

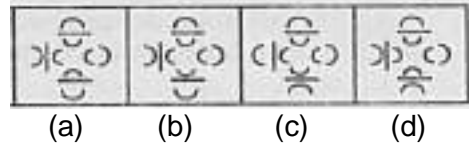

Q87.

Problem Figures:

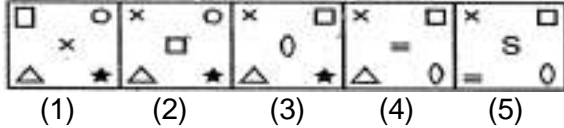

Answer Figures:

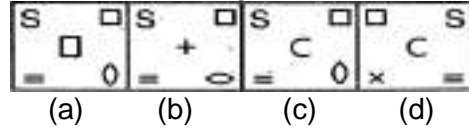

Q88.

Problem Figures:

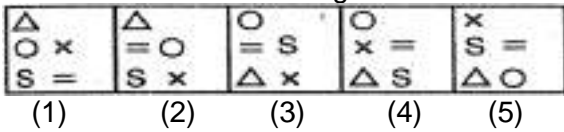

Answer Figures:

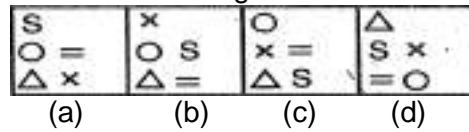

Q89.

Problem Figures:

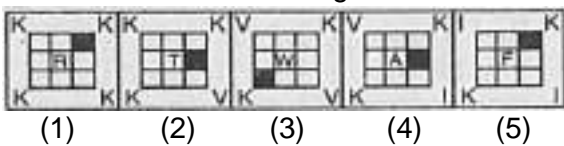

Answer Figures:

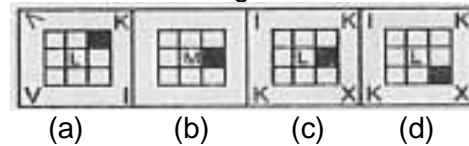

Q90.

Problem Figures:

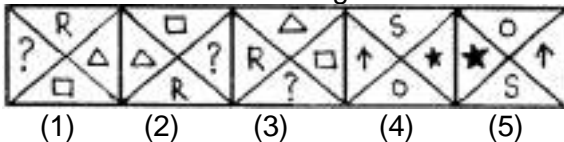

Answer Figures:

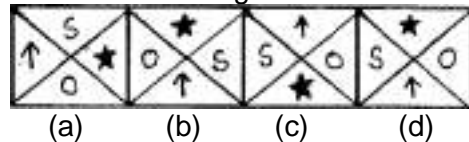

Q91-95. Each of the following questions consists of two sets of figures. Figures 1, 2, 3 and 4 constitute the Problem Set while figures a, b, c and d constitute the Answer Set. There is a definite relationship between figures (1) and (2). Establish a similar relationship between figures (3) and (4) by selecting a suitable figure from the Answer set that would replace the question mark (?) in fig (4).

Q91.

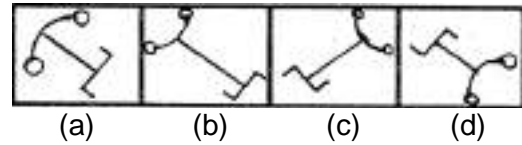
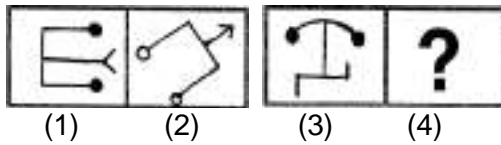

Q92.

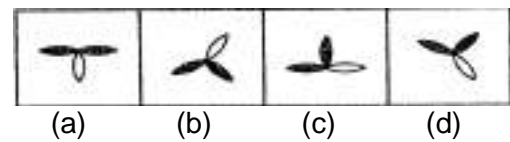
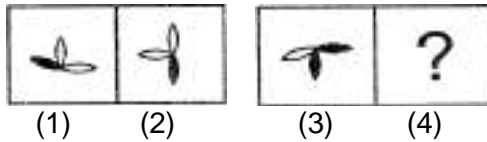

Q93.

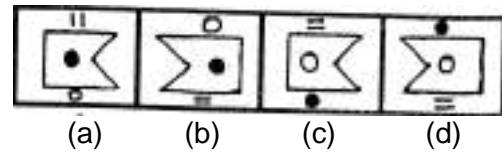
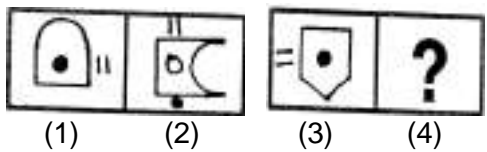

Q94.

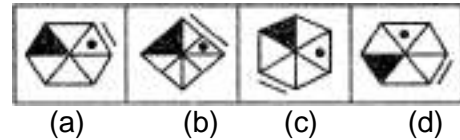
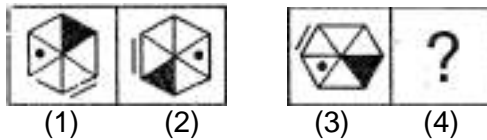

Q95.

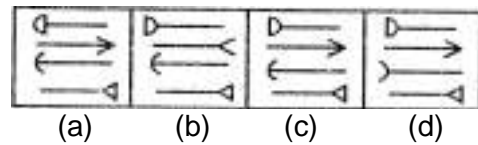
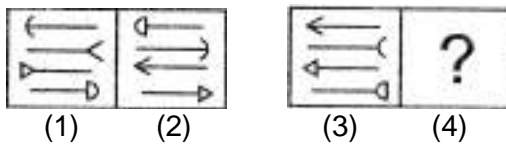

Q96-100. In each problem, out of the four figures marked (a) (b) (c) and (d) three are similar in a certain manner. However, one figure is not like the other three. Choose the figure which is different from the rest.

Q96.

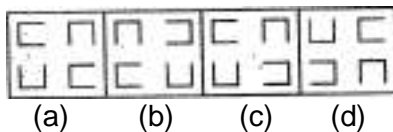

Q97.

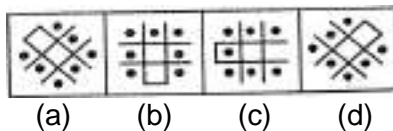

Q98.

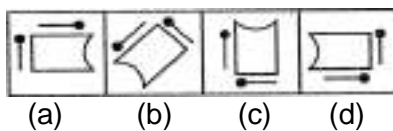

Q99.

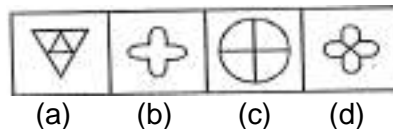

Q100.

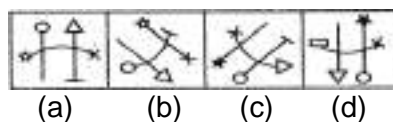

AFCAT Model Question Paper-IV

TIME ALLOTTED – 2HRS

INSTRUCTIONS FOR CANDIDATES

1. Total No Of Questions-100. Each Question is of three marks.
2. One mark will be deducted for every wrong answer.
3. No mark will be deducted for un-attempted questions.
4. Do not write on the Question Paper or make any mark on it.

Q1-4. Choose the word which is nearest in meaning to the given word:-

- Q1. Sagacious
(a) Stupid (b) Truthful (c) Lustful (d) Discerning
- Q2. Pontificate
(a) To speak authoritatively (b) To raise to higher office
(c) To act clumsily (d) To constitute
- Q3. Embellish
(a) Employ (b) Arrange
(c) Decorate (d) Design
- Q4. Damp Squib
(a) Insignificant happening (b) An old technique
(c) Unsuccessful attempt (d) Short, shrill cry

Q5-8. Choose the word that best defines the given phrases:-

- Q5. All agog
(a) Work helplessly (b) Lose consciousness
(c) In a state of excitement (d) Fall flat
- Q6. Espirit de Corps
(a) Bravery (b) Loyalty (c) Subordination (d) Unity
- Q7. Cloak and dagger
(a) To fight to a finish (b) To get into unexpected trouble
(c) To end the hostility (d) Like a spy
- Q8. To be at the end of one's tether
(a) To feel offended (b) To draw moral attention
(c) To have no resources left (d) To think deeply

Q9-12. Choose the correctly spelt word:-

- Q9. (a) Hindrance (b) Hinderance (c) Hindrence (d) Hinderence
- Q10. (a) Perjery (b) Perjury (c) Purjury (d) Perjary
- Q11. (a) Reminiscene (b) Reminiscence (c) Reminicece (d) Remeniscence
- Q12. (a) Omminous (b) Omineous (c) Ominous (d) Omenous

Q13-16. Choose the word which is nearly opposite in meaning to the given word:-

- Q13. Sporadic
(a) Rare (b) Frequent (c) Sharp (d) Coordinated
- Q14. Exonerate
(a) Reject (b) Contract (c) Accuse (d) Admit
- Q15. Parsimonious
(a) Generous (b) Selfish (c) Religious (d) Hereditary
- Q16. Vindicate
(a) Censure (b) Favour (c) Indicate (d) Eradicate

Q17-19. Read the following passage carefully and answer the questions given below it:-

Recently, a newspaper article mourned the total disappearance of the common house sparrow. This was a comment on the city's perceptible move towards edging out the flora and fauna of the city. In the rapid urbanization, multi-storied apartments grew and large scale felling of trees became necessary. Last week, however, seven pairs of these sparrows were spotted in a suburb. Possibly the greenery of this place has created a new habitat for these birds which like their proximity to human beings, and have made a comeback. A systematic development of trees and shrubs all over the city could woo the absentee house sparrow to our midst.

- Q17. According to the passage, the birds have made a comeback to the suburb because they
- have been hunted down by the village people
 - Love to be amidst human beings
 - get food only where human beings live
 - they have been deliberately brought back by biologists
- Q18. In the passage the term "urbanisation" has been used to refer to
- the destruction of the greenery in the city
 - construction of concrete structures on a large scale
 - a change over from the rural life to the city life
 - the movement of people from villages to cities
- Q19. The phrase "absentee house sparrow" refers to
- the sparrow that makes infrequent visits
 - the sparrow that has forgotten its habitat
 - the sparrow that has gone away from the urban areas
 - the sparrow that has become extinct

Q20-25 Select the most appropriate word from the options against each number:-

Watermelons ..(20).. to India by the 4th century A.D. Sushruta, the great Indian physician,(21)...wrote Sushruta Samhit, mentions that watermelons were grown ..(22).. the banks of the river Indus.(23)....are also mentioned in ancient books. Sushruta calls it as Kalinda or Kalinga (hence Kalingad in Marathi). It was...(24)..to China in the 10th or 11th century and ...(25)... it is grown throughout the tropics.

- Q20. (a) came (b) go (c) arrived (d) started
- Q21. (a) did (b) when (c) certainly (d) who
- Q22. (a) above (b) outside (c) from (d) along
- Q23. (a) it (b) they (c) some (d) that
- Q24. (a) took (b) gave (c) taken (d) take
- Q25. (a) also (b) though (c) now (d) tomorrow

Q26-29. Which word or words explains the meaning of the following idioms:-

- Q26. Lay bare
- Expose
 - Take off all clothes
 - Destroy
 - Exploit
- Q27. A wolf in sheep's clothing
- A hypocrite
 - A wolf in woolen clothes
 - A coward
 - A proud man
- Q28. A blue stocking
- Stocking which is blue in colour
 - A clean cheat
 - An unreliable person
 - a woman having literary tastes and learning
- Q29. Yeoman's service
- lip-service
 - to serve like a slave
 - to play god father
 - efficient or useful help

Q30-65. Choose the most appropriate answer:-

- Q30. Which country will host the XXXI Olympic Games in 2016?
 (a) Rio de Janeiro, Brazil (b) Chicago, USA
 (c) Tokyo, Japan (d) Doha, Qatar
- Q31. The book, 'A China Passage' was written by
 (a) MJ Akbar (b) Jagmohan
 (c) Anees Jung (d) John Kenneth Galbraith
- Q32. Who was the founder of Nanda dynasty?
 (a) Bimbisara (b) Mahapadma Nanda
 (c) Ajatasatru (d) Dhana Nanda
- Q33. Which of the following books is written by Arnold Toynbee?
 (a) Mankind and Mother Earth (b) Tom Sawyer
 (c) The Future of Freedom (d) The Moon's Last Sigh
- Q34. The national emblem, viz four lions standing back to back is an adaptation from which of the following:-
 (a) Sarnath lions (b) Gir lions
 (c) Khajurao (d) Ajanta caves
- Q35. Who was the person behind conversion of East India Company from a trading company into a regional power?
 (a) Lord Warren Hastings (b) Lord Clive
 (c) Lord Dalhousie (d) Lord Wellesley
- Q36. Who inscribed the name of Khalifa of Baghdad on his coins?
 (a) Ala-ud-din Khilji (b) Iltutmish
 (c) Qutub-ud-din Aibak (d) Balban
- Q37. Who among the following is not a recipient of the 'Bharatiya Jnanpith' Award?
 (a) Ashapurna Devi (b) MF Hussain
 (c) Raghupati Sahay (d) VK Gokak
- Q38. Global 500 awards are given for outstanding achievement in which of the following fields?
 (a) Population Control (b) Elimination of illiteracy
 (c) Campaigning against AIDS (d) Protection of environment
- Q39. Who among the following Sultans of Delhi assumed the title, 'Sikandar-i-Sani'?
 (a) Balban (b) Ala-ud-din Khilji
 (c) Muhammad-bin-Tughlaq (d) Sikander Lodhi
- Q40. UN General Assembly recently declared 21st June as
 (a) International Youth Day (b) International Literacy Day
 (c) International Day of Yoga (d) International Day of Peace
- Q41. Pulitzer Prize is awarded for outstanding work in the field of
 (a) Science and Technology (b) Environmental Studies
 (c) Literature and Journalism (d) International Understanding
- Q42. The presidency of the UN Security Council rotates among the Council Members
 (a) Every 6 months (b) Every year
 (c) Every 3 months (d) Every month
- Q43. The member countries of NAFTA are
 (a) USA, Canada and Mexico (b) Canada and Mexico
 (c) USA and Canada (d) Argentina and Brazil
- Q44. Who were the contemporaries of the Gupta Kings in the south?
 (a) Chola (b) Rashtrakutas
 (c) Satavahanas (d) Vakatakas
- Q45. Sandeep Sejwal won the Bronze medal in 2014 Asian Games in which of the following events?
 (a) 200m backstroke (b) 200m freestyle
 (c) 50m breaststroke (d) 50m butterfly

- Q46. Mangalyan, Mars Orbiter Mission (MOM) was launched in
 (a) Jan 2013 (b) Oct 2012 (c) Oct 2013 (d) Nov 2013
- Q47. "Ruhr of India" known for its rich coal deposits is in the State of
 (a) Uttar Pradesh (b) Jharkhand (c) West Bengal (d) Bihar
- Q48. The Indian space programme began in
 (a) 1961 (b) 1962 (c) 1965 (d) 1969
- Q49. 'Bachpan Bachao Andolan (BBA)', an organisation to protect the rights of children was founded by
 (a) Amir Khan (b) Kailash Satyarthi
 (c) Om Prakash Gurjar (d) Santa Sinha
- Q50. Which of the following Subsonic missiles, test fired in October 2014 is considered India's answer to America's Tomahawk missile?
 (a) Brahmos Mk-2 (b) Prahaar (c) Nirbhay (d) Agni-V
- Q51. Who among the following won the World Billiards Championship held in England in October 2014?
 (a) Peter Gilchrist (b) Pankaj Advani
 (c) Saurav Kothari (d) None of these
- Q52. The sum of ages of 4 children born at the interval of 2 years is 52. What is the age of the oldest child?
 (a) 10 years (b) 12 years (c) 14 years (d) 16 years
- Q53. A certain sum under compound interest, compounded annually, amounts to Rs. 5500/- in 5 years and Rs. 6050/- in 6 years. What is the rate of interest?
 (a) $12\frac{1}{2}\%$ (b) 15% (c) 20% (d) 10%
- Q54. Rs. 800 becomes Rs. 956 in 3 years at a certain rate of simple interest. If the rate of interest is increased by 4%, what amount will Rs. 800 becomes in 3 years?
 (a) Rs 1020.80 (b) Rs 1025 (c) Rs 1052 (d) Rs 1000
- Q55. A sum of money lent out at simple interest amounts to Rs 720 after 2 years and to Rs 1020 after a further period of 5 years. The sum is
 (a) Rs 500 (b) Rs 600 (c) Rs 700 (d) Rs 750
- Q56. Present age of X and Y are in the ratio 7:5 respectively. Four years hence, the ratio of their ages will become 11:9 respectively. What is the present age of Y?
 (a) 1 year (b) 7 year (c) 5 year (d) None of these
- Q57. A can do a piece of work in 20 days and B in 25 days. They work together for 5 days and then B goes away. In how many days will A finish the work?
 (a) 11 days (b) 9 days (c) 20 days (d) 21 days
- Q58. Two train A & B each 66 meters long run parallel to each other in the same direction. Their speeds are 50 Kmph and 30 Kmph respectively. In what time A will completely pass B.
 (a) 28 Sec (b) 28.46 Sec (c) 53.46 Sec (d) 23.76 Sec
- Q59. A train 77.5 m in length is running at the rate of 65 Kmph. Find the time taken by the train to pass the man walking in the same direction as the train @ 3 Kmph.
 (a) 2.5 Sec (b) 4.5 Sec (c) 6.5 Sec (d) 8 Sec
- Q60. Ram can row $7\frac{1}{2}$ Kmph in still water. If in a river running at 1.5 Km an hour, it takes him 50 minutes to row to a place and back, how far is the place?
 (a) 3.5 Km (b) 3 Km (c) 4.5 Km (d) 5 Km
- Q61. A motorboat with speed 15 Kmph in still water goes 30 Km downstream and comes back. It covers the distance in 4 hours and 30 minutes. The speed of the stream in Km/h is?
 (a) 4 (b) 5 (c) 6 (d) 10
- Q62. Zinc and copper are melted together in the ratio 9:11. What is the weight of the melted mixture, if 28.8 kg of zinc has been consumed in it?
 (a) 58 Kg (b) 60 Kg (c) 64 Kg (d) 70 Kg

- Q63. A sells his goods 20% cheaper than B and 20% dearer than C. How much percentage is C's goods cheaper / dearer than B.
 (a) 33.33% (b) 50% (c) 45.85% (d) None of these
- Q64. The average of 6 observations is 12. If the 7th observation is included, the average is reduced by 1. What will be the 7th observation?
 (a) 4 (b) 5 (c) 6 (d) 7
- Q65. If the incomes of Ram & Shyam are in the ratio of 3:4 and their expenditures in the ratio of 4:5, find the ratio of their savings, given that Shyam saves a third of his income.
 (a) 10:15 (b) 13:20 (c) 15:20 (d) 13:15

Q66-70 In each of the following questions find out the alternative which will replace the question mark.

- Q66. Sadist : Injury :: ??
 (a) Opportunist : Generosity (b) Priest : Church
 (c) Dentist : Teeth (d) Thief : Robbery
- Q67. Lecherous : Carnal :: ??
 (a) Virile : Feeble (b) Diatribe : Abuse
 (c) Impede : Begin (d) Sunder : Link
- Q68. Cerebrum : Brain :: ??
 (a) Aorta : Hand (b) Ligament : Blood
 (c) Ventricle : Heart (d) Country : Universe
- Q69. Monument : Cenotaph :: ??
 (a) Orifice : Opening (b) Guide : Follower
 (c) Protect : Protocol (d) Sponsor : Cleave
- Q70. Meadow : Sheep :: ??
 (a) Stable : Horse (b) Hay : Insect
 (c) Grass : Grasshopper (d) Pasture : Cattle

Q71-75. In each of the following questions, select a figure from amongst the four alternatives, which when placed in the blank space of figure (X) would complete the pattern.

Q71.

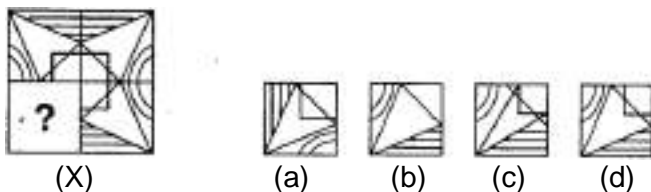

Q72.

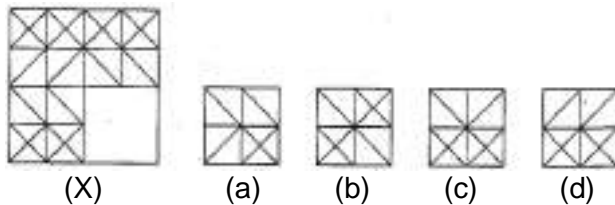

Q73.

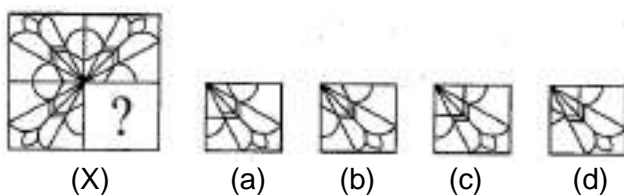

Q74.

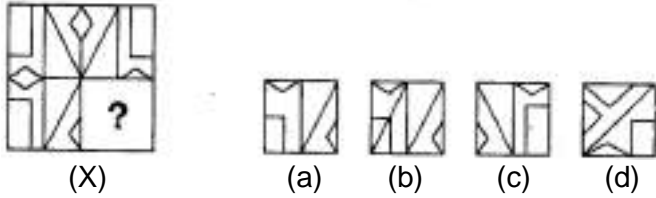

Q75.

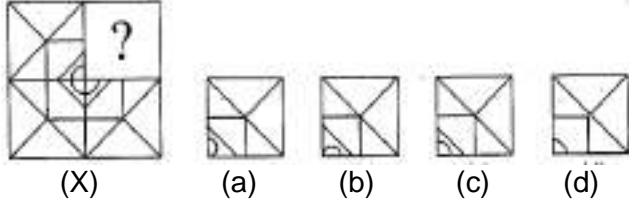

Q 76-80. Each of these questions given below contains three elements. These elements may or may not have some inter-linkage. Each group of elements may fit into one of these diagrams at (a), (b), (c) or (d). You have to indicate the group of elements which correctly fits into the diagrams.

Q76. Which of the following diagrams indicates the best relation between Biology, Zoology and Physics?

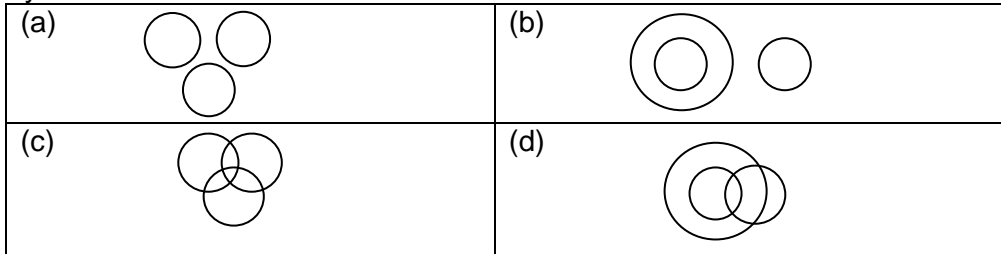

Q77. Which of the following diagrams indicates the best relation between Stamp, Pen and Chalk?

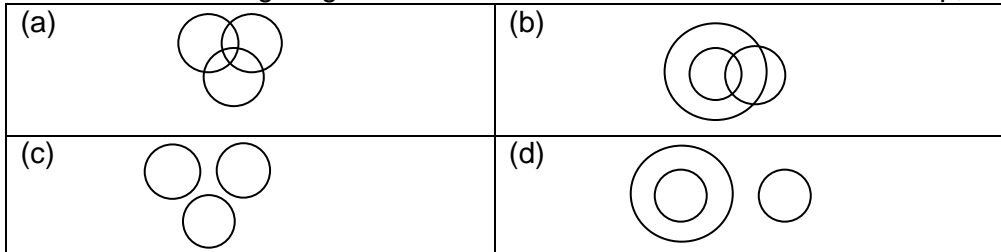

Q78. Which of the following diagrams indicates the best relation between Singers, Athletes and Girls?

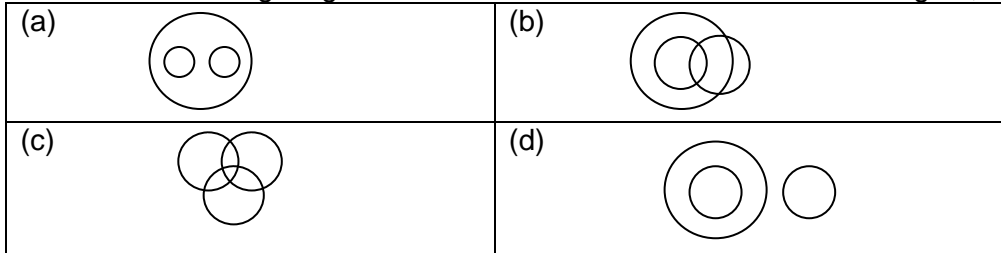

Q79. Which of the following diagrams indicates the best relation between Teachers, Women and Doctors?

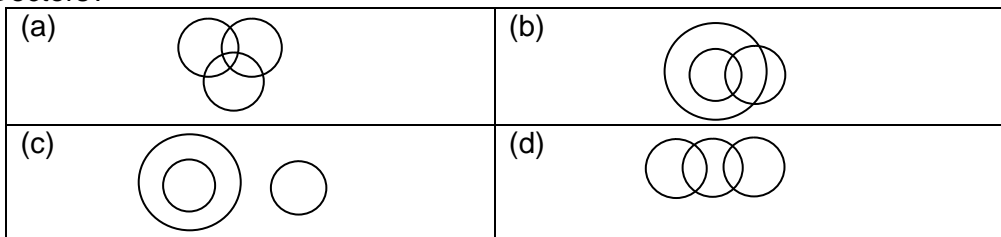

Q80. Which of the following diagrams indicates the best relation between Clothes, Flowers and White?

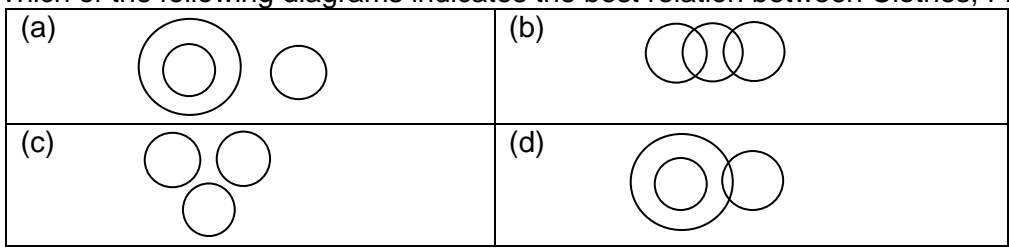

Q81-85. Each of the following questions consists of five figures marked 1,2,3,4 and 5 called the Problem Figures followed by four other figures marked a, b, c and d called the Answer Figures. Select a figure from amongst the Answer Figures which will continue the same series as established by the five Problem Figures.

Q81

Problem Figures:

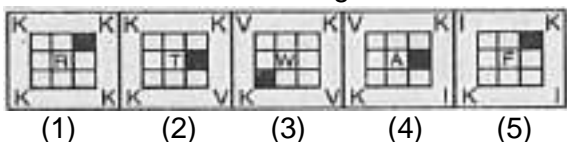

Answer Figures:

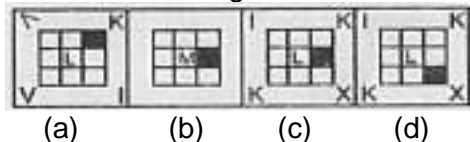

Q82.

Problem Figures:

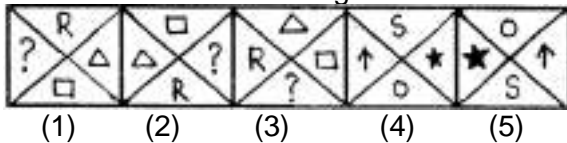

Answer Figures:

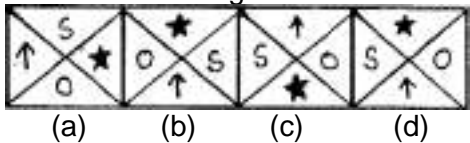

Q83.

Problem Figures:

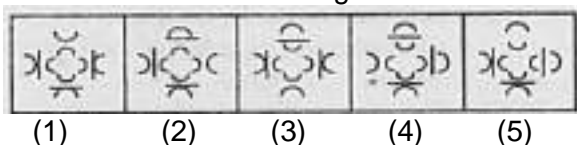

Answer Figures:

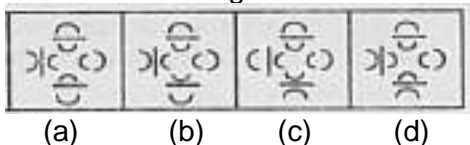

Q84.

Problem Figures:

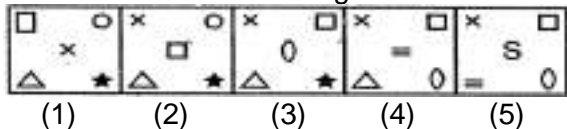

Answer Figures:

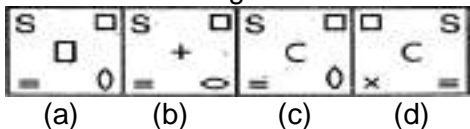

Q85.

Problem Figures:

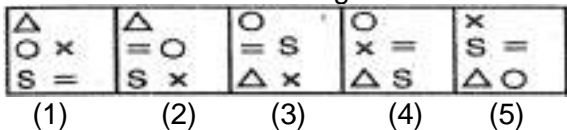

Answer Figures:

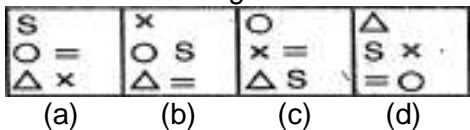

Q86-90. Each of the following questions consists of two sets of figures. Figures 1, 2, 3 and 4 constitute the Problem Set while figures a, b, c and d constitute the Answer Set. There is a definite relationship between figures (1) and (2). Establish a similar relationship between figures (3) and (4) by selecting a suitable figure from the Answer set that would replace the question mark (?) in fig (4).

Q86.



Q87.



Q88.

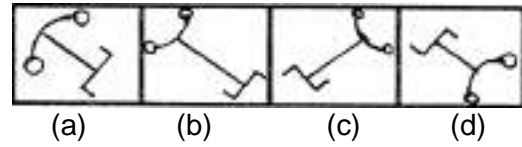
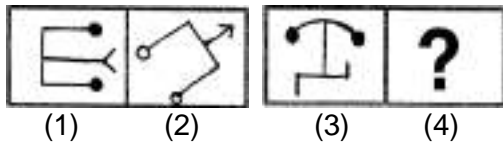

Q89.

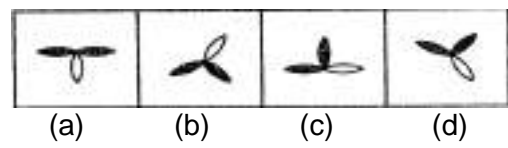
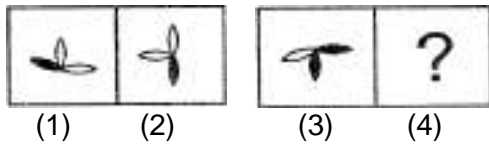

Q90.

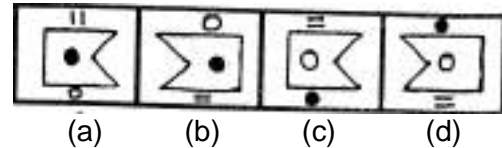
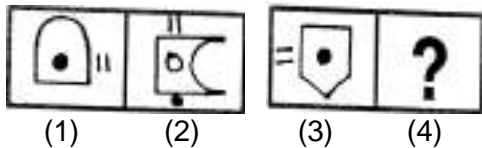

Q91-95. In each problem, out of the four figures marked (a) (b) (c) and (d) three are similar in a certain manner. However, one figure is not like the other three. Choose the figure which is different from the rest.

Q91.

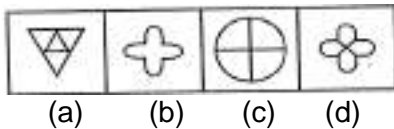

Q92.

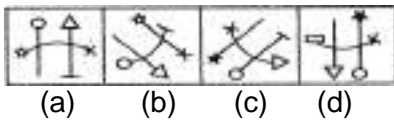

Q93.

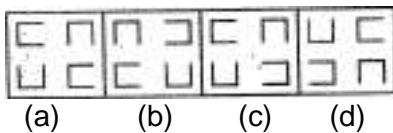

Q94.

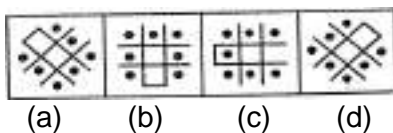

Q95.

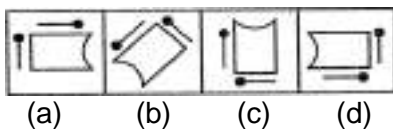

Q96-100 In each of the following questions, four words have been given out of which three are alike in some manner, while the fourth one is different. Choose the word which is different from the rest.

Q96. (a) Mendicant (b) Ascetic (c) Pious (d) Hermit

Q97. (a) Bardoli (b) Bhadravati (c) Porbandar (d) Champaran

Q98. (a) Niger (b) Suez (c) Mississippi (d) Colorado

Q99. (a) Bang (b) Hiss (c) Whistle (d) Wink

Q100. (a) Gold (b) Silver (c) Bronze (d) Iron

ANSWER KEYS

AFCAT Model Question Paper-I

1(d)	2(b)	3(d)	4(b)	5(a)	6(d)	7(c)	8(a)	9(d)	10(d)
11(c)	12(c)	13(b)	14(a)	15(b)	16(b)	17(c)	18(c)	19(d)	20(c)
21(c)	22(a)	23(c)	24(c)	25(c)	26(b)	27(a)	28(d)	29(a)	30(c)
31(b)	32(b)	33(d)	34(a)	35(d)	36(c)	37(a)	38(a)	39(a)	40(a)
41(a)	42(d)	43(b)	44(c)	45(c)	46(b)	47(a)	48(d)	49(b)	50(b)
51(b)	52(c)	53(d)	54(c)	55(c)	56(c)	57(d)	58(d)	59(c)	60(b)
61(c)	62(c)	63(a)	64(b)	65(a)	66(d)	67(d)	68(a)	69(c)	70(a)
71(d)	72(c)	73(c)	74(d)	75(c)	76(c)	77(c)	78(c)	79(d)	80(c)
81(d)	82(c)	83(a)	84(b)	85(d)	86(c)	87(c)	88(a)	89(d)	90(c)
91(c)	92(c)	93(a)	94(d)	95(c)	96(a)	97(b)	98(c)	99(c)	100(d)

ANSWER KEYS

AFCAT Model Question Paper-II

1(b)	2(a)	3(d)	4(a)	5(b)	6(a)	7(d)	8(c)	9(a)	10(d)
11(c)	12(b)	13(d)	14(c)	15(b)	16(c)	17(a)	18(b)	19(d)	20(d)
21(b)	22(c)	23(c)	24(c)	25(d)	26(c)	27(c)	28(a)	29(c)	30(b)
31(c)	32(c)	33(a)	34(b)	35(a)	36(c)	37(c)	38(c)	39(d)	40(d)
41(c)	42(b)	43(b)	44(c)	45(d)	46(c)	47(b)	48(b)	49(d)	50(a)
51(d)	52(c)	53(a)	54(a)	55(a)	56(a)	57(a)	58(d)	59(b)	60(c)
61(c)	62(b)	63(a)	64(d)	65(b)	66(d)	67(c)	68(d)	69(c)	70(c)
71(d)	72(c)	73(a)	74(d)	75(a)	76(b)	77(d)	78(d)	79(c)	80(a)
81(d)	82(c)	83(c)	84(c)	85(a)	86(c)	87(d)	88(c)	89(c)	90(c)
91(c)	92(d)	93(a)	94(b)	95(c)	96(a)	97(d)	98(c)	99(c)	100(c)

ANSWER KEYS

AFCAT Model Question Paper-III

1(d)	2(c)	3(b)	4(a)	5(d)	6(d)	7(b)	8(c)	9(c)	10(c)
11(c)	12(d)	13(a)	14(a)	15(a)	16(b)	17(c)	18(d)	19(c)	20(c)
21(d)	22(c)	23(a)	24(b)	25(b)	26(d)	27(d)	28(a)	29(a)	30(a)
31(b)	32(d)	33(c)	34(b)	35(a)	36(d)	37(d)	38(a)	39(b)	40(b)
41(c)	42(a)	43(c)	44(b)	45(b)	46(d)	47(b)	48(c)	49(b)	50(a)
51(d)	52(a)	53(d)	54(b)	55(b)	56(b)	57(c)	58(a)	59(b)	60(b)
61(d)	62(d)	63(c)	64(b)	65(c)	66(b)	67(c)	68(c)	69(d)	70(b)
71(c)	72(a)	73(d)	74(d)	75(b)	76(b)	77(d)	78(c)	79(c)	80(b)
81(a)	82(c)	83(c)	84(d)	85(d)	86(b)	87(c)	88(b)	89(c)	90(d)
91(b)	92(d)	93(d)	94(a)	95(c)	96(a)	97(c)	98(d)	99(b)	100(d)

ANSWER KEYS

AFCAT Model Question Paper-IV

1(d)	2(a)	3(c)	4(c)	5(c)	6(d)	7(d)	8(c)	9(a)	10(b)
11(b)	12(c)	13(b)	14(c)	15(a)	16(a)	17(b)	18(d)	19(c)	20(a)
21(d)	22(d)	23(b)	24(c)	25(c)	26(a)	27(a)	28(d)	29(d)	30(a)
31(d)	32(b)	33(a)	34(a)	35(a)	36(b)	37(b)	38(d)	39(b)	40(c)
41(c)	42(d)	43(a)	44(d)	45(c)	46(d)	47(b)	48(b)	49(b)	50(c)
51(b)	52(d)	53(d)	54(c)	55(b)	56(c)	57(a)	58(d)	59(b)	60(b)
61(b)	62(c)	63(a)	64(b)	65(b)	66(d)	67(b)	68(c)	69(a)	70(d)
71(d)	72(d)	73(a)	74(c)	75(c)	76(b)	77(c)	78(c)	79(d)	80(b)
81(c)	82(d)	83(b)	84(c)	85(b)	86(a)	87(c)	88(b)	89(d)	90(d)
91(b)	92(d)	93(a)	94(c)	95(d)	96(c)	97(b)	98(b)	99(d)	100(c)

**EKT Model Question Paper (Computer
Science)-I**

Instructions for Candidates

Time Allotted: 45Minutes

1. **Total No. of Questions 50. Each Question is of three marks.**
2. **One mark will be deducted for every wrong answer.**
3. **No mark will be deducted for un-attempted questions**
4. **Do not write or make any mark on Question Paper.**

-
- Q1. If the centre of a circle is (-6,8) and it passes through the origin, then equation to its tangent at the origin is
(a) $2y=x$ (b) $4y=3x$ (c) $3y=4x$ (d) $3x+4y=0$
- Q2. The liquid is flowing separately through each of two pipes whose diameters are in the ratio of 2:1, if the ratio of the velocities of flow in the two pipes by 1:2, then the ratio of the amounts of the liquid flowing per sec through the pipe will be
(a) 2:1 (b) 1:1 (c) 4:1 (d) 1:8
- Q3. If $f(x) = x + |x^2 - 8|$ then the derivative of $f(x)$ at $x=3$ is
(a) 6 (b) 7 (c) 8 (d) -8
- Q4. Given $P(A) = 1/4$, $P(B)=1/3$ and $P(A \cup B)= 1/2$. Value of $P(A/B)$ is
(a) $1/4$ (b) $1/3$ (c) $1/6$ (d) $1/7$
- Q5. The angle between two vectors $a = i+2j-k$ and $b=2i+j+k$ is
(a) 30 deg (b) 45 deg (c) 60 deg (d) 90 deg
- Q6. Newton is unit of force. It is the unit in
(a) MKS system (b) CGS system
(c) FPS system (d) None of these
- Q7. A Farad is defined as
(a) stat coulomb /volt (b) coulomb/volt
(c) coulomb x volt (d) stat coulomb x volt
- Q8. Permeance of a magnetic circuit corresponds to the following quantity in electrical circuit
(a) conductivity (b) resistivity (c) conductance (d) resistance
- Q9. Hydrometer is an instrument for measuring
(a) relative humidity (b) pressure of water
(c) volume of liquids (d) specific gravity
- Q10. Radioactivity is a property of
(a) atomic nuclei (b) excited electron
(c) gamma rays (d) ultraviolet light
- Q11. If a plane is parallel to the plane of projection, it appears
(a) true size (b) as a line or edge
(c) foreshortened (d) as an oblique surface
- Q12. How is a J-K Flip Flop made to toggle
(a) $J=0, K=0$ (b) $J=1, K=0$ (c) $J=0, K=1$ (d) $J=1, K=1$
- Q13. No. of flip-flops used in decade counter
(a) 3 (b) 2 (c) 4 (d) None of these

- Q14. The decimal equivalent of the hexadecimal number E5 is
(a) 279 (b) 229 (c) 427 (d) 3000
- Q15. Which part of the computer is used for calculating and comparing?
(a) Disk unit (b) Control unit (c) ALU (d) Modem
- Q16. A CPU's processing power is measured in
(a) IPS (b) CIPS (c) MIPS (d) nano-seconds
- Q17. Which computer memory is volatile?
(a) RAM (b) ROM (c) EPROM (d) PROM
- Q18. The computer code for the interchange of information between terminals is
(a) ASCII (b) BCD (c) EBCDIC (d) All of these
- Q19. Which of the following is not a sequential storage device?
(a) Magnetic disk (b) Magnetic tape (c) Paper tape (d) All of these
- Q20. The data recording area between the blank gaps on magnetic tape is called a/an:
(a) record (b) block (c) field (d) database
- Q21. On a systems flowchart, the online manual keeping of input data is identified by using the
(a) online storage symbol (b) online keyboard symbol
(c) keeping operation symbols (d) manual operation symbols
- Q22. An example of a hierarchical data structure is
(a) array (b) link list (c) tree (d) ring
- Q23. Which of the following system software does the job of merging the records from two files into one?
(a) security software (b) utility program
(c) networking software (d) documentation system
- Q24. Virtual Memory
(a) is a method of memory allocation by which the program is subdivided into equal portions, or pages and core is subdivided into equal portions or blocks
(b) consists of those addresses that may be generated by a processor during execution of a computation
(c) is a method of allocating processor time
(d) allows multiple programs to reside in separate areas of core at the time
- Q25. Which is a permanent database in the general model of compiler?
(a) literal Table (b) identifier Table
(c) terminal Table (d) source code
- Q26. Operating system functions may include
(a) input/output control (b) virtual storage
(c) multi-programming (d) all of these
- Q27. Moving process from main memory to disk is called
(a) scheduling (b) caching (c) swapping (d) spooling

- Q28. In which addressing mode the contents of a register specified in the instruction are first decremented, and these contents are used as the effective address of the operands?
- (a) index addressing (b) indirect addressing
(c) auto increment (d) auto decrement
- Q29. In order to allow only one process to enter its critical section, binary semaphore are initialized to
- (a) 0 (b) 1 (c) 2 (d) 3
- Q30. The outstanding Invoice file should be stored on a Pardon Access Storage Device if
- (a) invoice data entry is on-line
(b) payment recording is done in a batch mode
(c) inquiries concerning payable are to be answered on-line
(d) last record points to the first record
- Q31. In SQL, which command(s) is/are used to enable/disable a database trigger?
- (a) ALTER TRIGGER (b) ALTER DATABASE
(c) ALTER TABLE (d) MODIFY TRIGGER
- Q32. The modify operation is likely to be done after
- (a) Delete (b) Look-up (c) Insert (d) all of these
- Q33. Which of the following is not a logical data-base structure?
- (a) tree (b) relational (c) network (d) chain
- Q34. Which of the following tools is not used in modelling the new system?
- (a) decision tables (b) data dictionary
(c) data-flow diagrams (d) all of these
- Q35. Difference between Decision-Tables and Decision Tree is (are) :
- (a) value to end user
(b) form of representation
(c) one shows the logic while other shows the process
(d) all of the above
- Q36. The reservation system of Indian railways is an example of
- (a) transaction processing system
(b) interactive decision support system
(c) management controls system
(d) expert system
- Q37. The network layer, in reference to the OSI model, provide
- (a) data link procedures that provide for the exchange of data via frames that can be sent and received
(b) the interface between the X.25 network and packet mode device
(c) the virtual circuit interface to packet-switched service
(d) all of the above

- Q38. Which of the following is an important characteristic of LAN?
- (a) application independent interfaces
 - (b) unlimited expansion
 - (c) low cost access for low bandwidth channels
 - (d) parallel transmission
- Q39. Which of the following TCP/IP protocol is used for transferring electronic mail messages from one machine to another?
- (a) FTP
 - (b) SNMP
 - (c) SMTP
 - (d) RPC
- Q40. The slowest transmission speeds are those of
- (a) twisted-pair wire
 - (b) coaxial cable
 - (c) fiber-optic cable
 - (d) microwaves
- Q41. How many digits of the Network User Address are known as the DNIC (Data Network Identification Code)?
- (a) first three
 - (b) first four
 - (c) first five
 - (d) first seven
- Q42. The most flexibility in how devices are wired together is provided by
- (a) bus networks
 - (b) ring networks
 - (c) star networks
 - (d) T-switched networks
- Q43. An FM signal contains intelligence in
- (a) it's frequency variations
 - (b) it's amplitude variations
 - (c) both amplitude and frequency variations
 - (d) none of these
- Q44. In PCM system
- (a) a large bandwidth is required
 - (b) the biggest disadvantage is its incompatibility with TDM
 - (c) companding is used to overcome quantising noise
 - (d) none of the above
- Q45. The all-day efficiency of a transformer depends on
- (a) its copper loss
 - (b) its iron loss
 - (c) both (a) & (b)
 - (d) None of these
- Q46. Slip rings for induction motor are made of
- (a) copper
 - (b) aluminium
 - (c) carbon
 - (d) phosphor bronze
- Q47. One of the characteristic of single phase motor is that it
- (a) is self-starting
 - (b) is not self-starting
 - (c) requires only one winding
 - (d) can rotate in one direction only
- Q48. If the input to a differentiating ckt is saw -tooth wave then output will be-----wave
- (a) Square
 - (b) Rectangular
 - (c) Triangular
 - (d) Saw-tooth
- Q49. Which gate acts as universal gate?
- (a) AND
 - (b) NAND
 - (c) OR
 - (d) EX-OR
- Q50. A 32 bit microprocessor has word length equal to
- (a) 1 byte
 - (b) 2 byte
 - (c) 4 byte
 - (d) 8 byte

**EKT Model Question Paper (Computer
Science)-II**

Instructions for Candidates

Time Allotted: 45 Minutes

1. **Total No. of Questions 50. Each Question is of three marks.**
 2. **One mark will be deducted for every wrong answer.**
 3. **No mark will be deducted for un-attempted questions**
 4. **Do not write or make any mark on Question Paper.**
-

- Q1. If a plane is parallel to the plane of projection, it appears
- (a) true size (b) as a line or edge
(c) foreshortened (d) as an oblique surface
- Q2. How is a J-K Flip Flop made to toggle
- (a) J=0, K=0 (b) J=1, K=0 (c) J=0, K=1 (d) J=1, K=1
- Q3. No. of flip-flops used in decade counter
- (a) 3 (b) 2 (c) 4 (d) None of these
- Q4. The decimal equivalent of the hexadecimal number E5 is
- (a) 279 (b) 229 (c) 427 (d) 3000
- Q5. Which part of the computer is used for calculating and comparing?
- (a) Disk unit (b) Control unit (c) ALU (d) Modem
- Q6. Difference between Decision-Tables and Decision Tree is (are) :
- (a) value to end user
(b) form of representation
(c) one shows the logic while other shows the process
(d) all of the above
- Q7. The reservation system of Indian railways is an example of
- (a) transaction processing system
(b) interactive decision support system
(c) management controls system
(d) expert system
- Q8. The network layer, in reference to the OSI model, provide
- (a) data link procedures that provide for the exchange of data via frames that can be sent and received
(b) the interface between the X.25 network and packet mode device
(c) the virtual circuit interface to packet-switched service
(d) all of the above
- Q9. Which of the following is an important characteristic of LAN?
- (a) application independent interfaces
(b) unlimited expansion
(c) low cost access for low bandwidth channels
(d) parallel transmission

- Q10. Which of the following TCP/IP protocol is used for transferring electronic mail messages from one machine to another?
- (a) FTP (b) SNMP (c) SMTP (d) RPC
- Q11. The slowest transmission speeds are those of
- (a) twisted-pair wire (b) coaxial cable
(c) fiber-optic cable (d) microwaves
- Q12. A CPU's processing power is measured in
- (a) IPS (b) CIPS (c) MIPS (d) nano-seconds
- Q13. Which computer memory is volatile?
- (a) RAM (b) ROM (c) EPROM (d) PROM
- Q14. The computer code for the interchange of information between terminals is
- (a) ASCII (b) BCD (c) EBCDIC (d) All of these
- Q15. Which of the following is not a sequential storage device?
- (a) Magnetic disk (b) Magnetic tape (c) Paper tape (d) All of these
- Q16. The data recording area between the blank gaps on magnetic tape is called a/an:
- (a) record (b) block (c) field (d) database
- Q17. On a systems flowchart, the online manual keeping of input data is identified by using the
- (a) online storage symbol (b) online keyboard symbol
(c) keeping operation symbols (d) manual operation symbols
- Q18. An example of a hierarchical data structure is
- (a) array (b) link list (c) tree (d) ring
- Q19. Which of the following system software does the job of merging the records from two files into one?
- (a) security software (b) utility program
(c) networking software (d) documentation system
- Q20. Virtual Memory
- (a) is a method of memory allocation by which the program is subdivided into equal portions, or pages and core is subdivided into equal portions or blocks
(b) consists of those addresses that may be generated by a processor during execution of a computation
(c) is a method of allocating processor time
(d) allows multiple programs to reside in separate areas of core at the time
- Q21. Which is a permanent database in the general model of compiler?
- (a) literal Table (b) Identifier Table
(c) terminal Table (d) source code
- Q22. Operating system functions may include
- (a) input/output control (b) virtual storage
(c) multi-programming (d) All of these
- Q23. Moving process from main memory to disk is called
- (a) scheduling (b) caching (c) swapping (d) spooling

- Q24. In which addressing mode the contents of a register specified in the instruction are first decremented, and these contents are used as the effective address of the operands?
- (a) index addressing (b) indirect addressing
(c) auto increment (d) auto decrement
- Q25. In order to allow only one process to enter its critical section, binary semaphore are initialized to
- (a) 0 (b) 1 (c) 2 (d) 3
- Q26. The outstanding Invoice file should be stored on a Pardon Access Storage Device if
- (a) invoice data entry is on-line
(b) payment recording is done in a batch mode
(c) inquiries concerning payable are to be answered on-line
(d) last record points to the first record
- Q27. In SQL, which command(s) is/are used to enable/disable a database trigger?
- (a) ALTER TRIGGER (b) ALTER DATABASE
(c) ALTER TABLE (d) MODIFY TRIGGER
- Q28. The modify operation is likely to be done after
- (a) Delete (b) Look-up (c) Insert (d) all of these
- Q29. Which of the following is not a logical data-base structure?
- (a) tree (b) relational (c) network (d) chain
- Q30. Which of the following tools is not used in modelling the new system?
- (a) decision tables (b) data dictionary
(c) data-flow diagrams (d) all of these
- Q31. How many digits of the Network User Address are known as the DNIC (Data Network Identification Code)?
- (a) first three (b) first four (c) first five (d) first seven
- Q32. The most flexibility in how devices are wired together is provided by
- (a) bus networks (b) ring networks (c) star networks (d) T-switched networks
- Q33. An FM signal contains intelligence in
- (a) it's frequency variations (b) it's amplitude variations
(c) both amplitude and frequency variations (d) none of these
- Q34. In PCM system
- (a) a large bandwidth is required
(b) the biggest disadvantage is its incompatibility with TDM
(c) companding is used to overcome quantising noise
(d) none of the above
- Q35. The all-day efficiency of a transformer depends on
- (a) its copper loss (b) its iron loss
(c) both (a) & (b) (d) None of these
- Q36. Slip rings for induction motor are made of
- (a) copper (b) aluminium (c) carbon (d) phosphor bronze

- Q37. One of the characteristic of single phase motor is that it
 (a) is self-starting (b) is not self-starting
 (c) requires only one winding (d) can rotate in one direction only
- Q38. If the input to a differentiating ckt is saw-tooth wave then output will be-----wave
 (a) Square (b) Rectangular (c) Triangular (d) Saw-tooth
- Q39. Which gate acts as universal gate?
 (a) AND (b) NAND (c) OR (d) EX-OR
- Q40. A 32 bit microprocessor has word length equal to
 (a) 1 byte (b) 2 byte (c) 4 byte (d) 8 byte
- Q41. If the centre of a circle is (-6,8) and it passes through the origin, then equation to its tangent at the origin is
 (a) $2y=x$ (b) $4y=3x$ (c) $3y=4x$ (d) $3x+4y=0$
- Q42. The liquid is flowing separately through each of two pipes whose diameters are in the ratio of 2:1, if the ratio of the velocities of flow in the two pipes by 1:2, then the ratio of the amounts of the liquid flowing per sec through the pipe will be
 (a) 2:1 (b) 1:1 (c) 4:1 (d) 1:8
- Q43. If $f(x) = x + |x^2 - 8|$ then the derivative of $f(x)$ at $x=3$ is
 (a) 6 (b) 7 (c) 8 (d) -8
- Q44. Given $P(A) = 1/4$, $P(B)=1/3$ and $P(A \cup B)= 1/2$. Value of $P(A/B)$ is
 (a) $1/4$ (b) $1/3$ (c) $1/6$ (d) $1/7$
- Q45. Permeance of a magnetic circuit corresponds to the following quantity in electrical circuit
 (a) conductivity (b) resistivity (c) conductance (d) resistance
- Q46. Hydrometer is an instrument for measuring
 (a) relative humidity (b) pressure of water
 (c) volume of liquids (d) specific gravity
- Q47. Radioactivity is a property of
 (a) atomic nuclei (b) excited electron
 (c) gamma rays (d) ultraviolet light
- Q48. The angle between two vectors $a = i+2j-k$ and $b=2i+j+k$ is
 (a) 30 deg (b) 45 deg (c) 60 deg (d) 90 deg
- Q49. Newton is unit of force. It is the unit in
 (a) MKS system (b) CGS system
 (c) FPS system (d) None of these
- Q50. A Farad is defined as
 (a) stat coulomb /volt (b) coulomb/volt
 (c) coulomb x volt (d) stat coulomb x volt

**EKT Model Question Paper (Electrical &
Electronics)-I**

Instructions for Candidates

Time Allotted: 45 Minutes

1. Total No. of Questions 50. Each Question is of three marks.
2. One mark will be deducted for every wrong answer.
3. No mark will be deducted for un-attempted questions.
4. Do not write on the Question Paper or make any mark on it.

- Q1. If $x=a(\cos t + t \sin t)$, $y=a(\sin t - t \cos t)$. The value of $\frac{dy}{dx}$ is
(a) $\cos t$ (b) $\sin t$ (c) $\tan t$ (d) $\sec^2 t$
- Q2. The area of three faces of a cuboid are in the ratio 2:3:4 and its volume is 9000 cm^3 . The length of the shortest edge is
(a) 15 cm (b) 30 cm (c) 20 cm (d) 60 cm
- Q3. $\int \frac{dx}{x \log x}$ is equal to
(a) $\log x + x + c$ (b) $\log(\log x) + c$ (c) $x \log x + c$ (d) $\frac{\log x}{x} + c$
- Q4. Tickets numbered 1 to 20 are mixed up and then a ticket is drawn at random. What is the probability that the ticket drawn has a number which is a multiple of 3 or 5?
(a) $\frac{8}{2}$ (b) $\frac{9}{20}$ (c) $\frac{8}{15}$ (d) $\frac{2}{20}$
- Q5. The projection of a vector on another vector is
(a) Scalar (b) Vector
(c) neither vector nor scalar (d) either scalar or vector
- Q6. In MKS system, we measure
(a) mass in kilogram (b) distance in meter
(c) time in second (d) all of these
- Q7. When the separation between two charges is made four times, the force between them
(a) increases four times (b) decreases four times
(c) increases sixteen times (d) decreases sixteen times
- Q8. When a conductor cuts magnetic flux, an emf is induced in the conductor. This is known as
(a) Joule's law (b) Faraday's law
(c) Coulomb's law (d) Ampere's law
- Q9. X-rays are used for the study of crystal structure because
(a) X-rays are completely absorbed by the crystal
(b) the wavelength of X-ray is of the same order of magnitude in the inter-atomic spacing in crystals
(c) the wavelength of X-rays is very small in comparison with the inter-atomic spacing in crystals
(d) the crystals are completely transparent to X-rays

- Q10. A radioactive isotope has a half-life of 10 days. If today there are 125 g of it left, what was its original weight 40 days earlier
(a) 600 g (b) 1000 g (c) 1250 g (d) 2000 g
- Q11. Angles project true size only when the plane containing the angle and plane of projection are
(a) Aligned (b) Adjacent (c) Perpendicular (d) Parallel
- Q12. Tesla is a measure of
(a) magnetic flux density (b) electric flux density
(c) magnetic potential (d) electric potential
- Q13. Admittance is reciprocal of
(a) susceptance (b) impedance (c) reactance (d) conductance
- Q14. _____ is an active filter
(a) RC filter (b) notch filter (c) Butterworth filter (d) band pass filter
- Q15. For transmission line load matching over a range of frequencies, it is best to use a
(a) Balun (b) broadband directional coupler
(c) double stub (d) single stub
- Q16. Emitter follower is used for
(a) reducing the gain (b) increasing the distortion
(c) impedance matching (d) none of these
- Q17. Binary equivalent of $(45)_{10}$ is
(a) $(11101)_2$ (b) $(11110)_2$ (c) $(101101)_2$ (d) $(110101)_2$
- Q18. In Computer memory size K indicates Kilo, which is equal to
(a) 1000 (b) 1024 (c) 100 (d) 10000
- Q19. An astable multivibrator has
(a) no stable state (b) one stable state (c) three stable states (d) two stable states
- Q20. An ideal Op Amp has
(a) infinite input and output impedance
(b) very low input and output impedance
(c) low input impedance and very high output impedance
(d) infinite input impedance and zero output impedance
- Q21. An instruction used to set the carry flag in a computer can be classified as a
(a) data transfer instruction (b) arithmetic instruction
(c) logical instruction (d) program control instruction
- Q22. An FET is a
(a) bipolar semiconductor device (b) unipolar semiconductor device
(c) non semiconductor device (d) both (a) and (c)
- Q23. For Gunn diodes, semiconductor material preferred is
(a) Silicon (b) Germanium (c) Gallium Arsenide (d) all of these
- Q24. In a JFET drain current is maximum when V_{GS} is
(a) zero (b) negative (c) positive (d) equal to V_p

- Q25. The output of Laser is
 (a) Infrared (b) polarised (c) narrow beam (d) coherent
- Q26. As compared to a closed loop system an open loop system is
 (a) more stable as well as more accurate
 (b) less stable as well as less accurate
 (c) more stable but less accurate
 (d) less stable but more accurate
- Q27. Transfer function of a system is used to calculate
 (a) the steady state gain (b) the time constant
 (c) the order of the system (d) the output for a given input
- Q28. In a closed loop control system
 (a) control action depends upon the output and also on the input command
 (b) output signal is fed back to be compared with the reference signal
 (c) the accuracy is better than in the open loop system
 (d) all of the above
- Q29. The difference of the reference input and the actual output signal is called
 (a) error signal (b) controlling signal (c) actuating signal (d) transfer function
- Q30. If the transfer function of a system is $\frac{1}{Ts+1}$, the steady state error to unit step input is
 (a) T (b) zero (c) infinite (d) none of these
- Q31. In a PID controller, the values of proportional, integral and derivative are dependent on
 (a) future, past and present errors respectively
 (b) present, past and future errors respectively
 (c) past, present and future errors respectively
 (d) present, future and past errors respectively
- Q32. The inverse Laplace transform of $\frac{2}{s+1}$ is
 (a) $2(t+1)$ (b) $2e^{-t}$ (c) $2e^t$ (d) e^{-2t}
- Q33. The signal is extended from 96KHz to 100KHz, so the minimum sampling frequency required is
 (a) 8KHz (b) 200KHz (c) 4KHz (d) 100KHz
- Q34. A differentiation circuit has a
 (a) very high time constant (b) very low time constant
 (c) infinite time constant (d) zero time constant
- Q35. Ideally Voltage Standing Wave Ratio (VSWR) should be
 (a) as large as possible (b) as small as possible
 (c) as close to unity as possible (d) infinity
- Q36. Following is/are a property/properties of quantization
 (a) it is an nonlinear process (b) it is an irreversible process
 (c) it maps a larger set of input values to a smaller set (d) all of these

- Q37. Most commonly used filter in SSB generation are
(a) mechanical filters (b) RC filters (c) LC filters (d) low pass filters
- Q38. If the antenna diameter in a radar system is increased by a factor of 4, the maximum range will be increased by a factor of
(a) 2 (b) 4 (c) 8 (d) 16
- Q39. Following type of multiplexing cannot be used for analog signalling
(a) FDM (b) TDM (c) CDM (d) None of these
- Q40. In TDM systems, channel separation is done with the use of
(a) AND gates (b) band-pass filters (c) differentiator circuit (d) integrator circuit
- Q41. Data-link layer of the OSI model specifies
(a) data link procedures that provide for the exchange of data via frames that can be sent and received
(b) the interface between the X.25 network and packet mode device
(c) the virtual circuit interface to packet-switched service
(d) all of the above
- Q42. FDDI is a
(a) ring network (b) star network (c) mesh network (d) bus based network
- Q43. Which of the following TCP/IP protocol allows an application program on one machine to send a datagram to an application program on another machine?
(a) UDP (b) VMTP (c) X.25 (d) SMTP
- Q44. The main difference between synchronous and asynchronous transmission is that
(a) the clocking is derived from the data in synchronous transmission
(b) the clocking is mixed with the data in asynchronous transmission
(c) the pulse height is different
(d) the bandwidth required is different
- Q45. Transducer is a device which
(a) converts one form of power in to the other (b) is similar to transformer
(c) converts one form of energy in to other (d) helps in measuring electricity
- Q46. Principle of hysteresis is not used in
(a) electrical water geyser (b) electrical motor (c) multi-vibrators (d) Schmitt trigger
- Q47. Which of the following motors would not be suitable for use as servomotors?
(a) AC induction motor (b) brushless AC motor
(c) stepper motor (d) permanent magnet DC motor
- Q48. The stator of an induction motor is made of
(a) carbon (b) wood (c) copper stampings (d) silicon steel laminators
- Q49. An ideal DC generator is one that has _____ voltage regulation
(a) low (b) high (c) zero (d) positive
- Q50. Commutator is used in
(a) DC generator (b) AC generator (c) invertors (d) convertors

EKT Model Question Paper (Electrical & Electronics)-II

Instructions for Candidates

Time Allotted: 45 Minutes

1. **Total No. of Questions 50. Each Question is of three marks.**
2. **One mark will be deducted for every wrong answer.**
3. **No mark will be deducted for un-attempted questions.**
4. **Do not write on the Question Paper or make any mark on it.**

- Q1. When a conductor cuts magnetic flux, an emf is induced in the conductor. This is known as
- (a) Joule's law (b) Faraday's law
(c) Coulomb's law (d) Ampere's law
- Q2. X-rays are used for the study of crystal structure because
- (a) X-rays are completely absorbed by the crystal
(b) the wavelength of X-ray is of the same order of magnitude in the inter atomic spacing in crystals
(c) the wavelength of X-rays is very small in comparison with the inter atomic spacing in crystals
(d) the crystals are completely transparent to X-rays
- Q3. Emitter follower is used for
- (a) reducing the gain (b) increasing the distortion
(c) impedance matching (d) none of these
- Q4. Binary equivalent of $(45)_{10}$ is
- (a) $(11101)_2$ (b) $(11110)_2$ (c) $(101101)_2$ (d) $(110101)_2$
- Q5. In Computer memory size K indicates Kilo, which is equal to
- (a) 1000 (b) 1024 (c) 100 (d) 10000
- Q6. An astable multivibrator has
- (a) no stable state (b) one stable state (c) three stable states (d) two stable states
- Q7. An ideal Op Amp has
- (a) infinite input and output impedance
(b) very low input and output impedance
(c) low input impedance and very high output impedance
(d) infinite input impedance and zero output impedance
- Q8. An instruction used to set the carry flag in a computer can be classified as a
- (a) data transfer instruction (b) arithmetic instruction
(c) logical instruction (d) program control instruction
- Q9. An FET is a
- (a) bipolar semiconductor device (b) unipolar semiconductor device
(c) non semiconductor device (d) both (a) and (c)
- Q10. For Gunn diodes, semiconductor material preferred is
- (a) Silicon (b) Germanium (c) Gallium Arsenide (d) all of these

- Q11. In a JFET drain current is maximum when V_{GS} is
 (a) zero (b) negative (c) positive (d) equal to V_p
- Q12. The output of Laser is
 (a) Infrared (b) polarised (c) narrow beam (d) coherent
- Q13. As compared to a closed loop system an open loop system is
 (a) more stable as well as more accurate
 (b) less stable as well as less accurate
 (c) more stable but less accurate
 (d) less stable but more accurate
- Q14. Transfer function of a system is used to calculate
 (a) the steady state gain (b) the time constant
 (c) the order of the system (d) the output for a given input
- Q15. In a closed loop control system
 (a) control action depends upon the output and also on the input command
 (b) output signal is fed back to be compared with the reference signal
 (c) the accuracy is better than in the open loop system
 (d) all of the above
- Q16. The difference of the reference input and the actual output signal is called
 (a) error signal (b) controlling signal (c) actuating signal (d) transfer function
- Q17. If the transfer function of a system is $\frac{1}{Ts+1}$, the steady state error to unit step input is
 (a) T (b) zero (c) infinite (d) none of these
- Q18. In a PID controller, the values of proportional, integral and derivative are dependent on
 (a) future, past and present errors respectively
 (b) present, past and future errors respectively
 (c) past, present and future errors respectively
 (d) present, future and past errors respectively
- Q19. The inverse Laplace transform of $\frac{2}{s+1}$ is
 (a) $2(t+1)$ (b) $2e^{-t}$ (c) $2e^t$ (d) e^{-2t}
- Q20. The signal is extended from 96KHz to 100KHz, so the minimum sampling frequency required is
 (a) 8KHz (b) 200KHz (c) 4KHz (d) 100KHz
- Q21. A differentiation circuit has a
 (a) very high time constant (b) very low time constant
 (c) infinite time constant (d) zero time constant
- Q22. Ideally Voltage Standing Wave Ratio (VSWR) should be
 (a) as large as possible (b) as small as possible
 (c) as close to unity as possible (d) infinity

- Q23. Following is/are a property/properties of quantization
(a) it is an nonlinear process (b) it is an irreversible process
(c) it maps a larger set of input values to a smaller set (d) all of these
- Q24. Most commonly used filter in SSB generation are
(a) mechanical filters (b) RC filters (c) LC filters (d) low pass filters
- Q25. If the antenna diameter in a radar system is increased by a factor of 4, the maximum range will be increased by a factor of
(a) 2 (b) 4 (c) 8 (d) 16
- Q26. Following type of multiplexing cannot be used for analog signalling
(a) FDM (b) TDM (c) CDM (d) None of these
- Q27. In TDM systems, channel separation is done with the use of
(a) AND gates (b) bandpass filters (c) differentiator circuit (d) integrator circuit
- Q28. A radioactive isotope has a half-life of 10 days. If today there are 125 g of it left, what was its original weight 40 days earlier
(a) 600 g (b) 1000 g (c) 1250 g (d) 2000 g
- Q29. Angles project true size only when the plane containing the angle and plane of projection are
(a) Aligned (b) Adjacent (c) Perpendicular (d) Parallel
- Q30. Tesla is a measure of
(a) magnetic flux density (b) electric flux density
(c) magnetic potential (d) electric potential
- Q31. Admittance is reciprocal of
(a) susceptance (b) impedance (c) reactance (d) conductance
- Q32. _____ is an active filter
(a) RC filter (b) notch filter (c) Butterworth filter (d) band pass filter
- Q33. For transmission line load matching over a range of frequencies, it is best to use a
(a) Balun (b) broadband directional coupler
(c) double stub (d) single stub
- Q34. Data-link layer of the OSI model specifies
(a) data link procedures that provide for the exchange of data via frames that can be sent and received
(b) the interface between the X.25 network and packet mode device
(c) the virtual circuit interface to packet-switched service
(d) all of the above
- Q35. FDDI is a
(a) ring network (b) star network (c) mesh network (d) bus based network
- Q36. Which of the following TCP/IP protocol allows an application program on one machine to send a datagram to an application program on another machine?
(a) UDP (b) VMTP (c) X.25 (d) SMTP
- Q37. The main difference between synchronous and asynchronous transmission is that
(a) the clocking is derived from the data in synchronous transmission
(b) the clocking is mixed with the data in asynchronous transmission
(c) the pulse height is different
(d) the bandwidth required is different

- Q38. Transducer is a device which
 (a) converts one form of power in to the other (b) is similar to transformer
 (c) converts one form of energy in to other (d) helps in measuring electricity
- Q39. Principle of hysteresis is not used in
 (a) electrical water geyser (b) electrical motor (c) multi-vibrators (d) Schmitt trigger
- Q40. Which of the following motors would not be suitable for use as servomotors?
 (a) AC induction motor (b) brushless AC motor
 (c) stepper motor (d) permanent magnet DC motor
- Q41. The stator of an induction motor is made of
 (a) carbon (b) wood (c) copper stampings (d) silicon steel laminators
- Q42. An ideal DC generator is one that has _____ voltage regulation
 (a) low (b) high (c) zero (d) positive
- Q43. Commutator is used in
 (a) DC generator (b) AC generator (c) invertors (d) convertors
- Q44. If $x=a(\cos t + t \sin t)$, $y=a(\sin t - t \cos t)$. The value of $\frac{dy}{dx}$ is
 (a) $\cos t$ (b) $\sin t$ (c) $\tan t$ (d) $\sec^2 t$
- Q45. The area of three faces of a cuboid are in the ratio 2:3:4 and its volume is 9000 cm^3 . The length of the shortest edge is
 (a) 15 cm (b) 30 cm (c) 20 cm (d) 60 cm
- Q46. $\int \frac{dx}{x \log x}$ is equal to
 (a) $\log x + x + c$ (b) $\log(\log x) + c$ (c) $x \log x + c$ (d) $\frac{\log x}{x} + c$
- Q47. Tickets numbered 1 to 20 are mixed up and then a ticket is drawn at random. What is the probability that the ticket drawn has a number which is a multiple of 3 or 5?
 (a) $\frac{8}{2}$ (b) $\frac{9}{20}$ (c) $\frac{8}{15}$ (d) $\frac{2}{20}$
- Q48. The projection of a vector on another vector is
 (a) Scalar (b) Vector
 (c) neither vector nor scalar (d) either scalar or vector
- Q49. In MKS system, we measure
 (a) mass in kilogram (b) distance in meter
 (c) time in second (d) all of these
- Q50. When the separation between two charges is made four times, the force between them
 (a) increases four times (b) decreases four times
 (c) increases sixteen times (d) decreases sixteen times

EKT Model Question Paper (Mechanical)-I

Instructions for Candidates**Time Allotted: 45 Minutes**

1. Total number of Questions 50. Each Question is of three marks.
 2. One mark will be deducted for every wrong answer.
 3. No mark will be deducted for un-attempted Question.
 4. Do not write or make any mark on Question Paper.
-

- Q1. If the centre of a circle is $(-6,8)$ and it passes through the origin, then equation to its tangent at the origin is
(a) $2y = x$ (b) $4y = 3x$ (c) $3y = 4x$ (d) $3x + 4y = 0$
- Q2. The liquid is flowing separately through each of two pipes whose diameters are in the ratio of 2:1, if the ratio of the velocities of flow in the two pipes by 1:2, then the ratio of the amounts of the liquid flowing per sec through the pipe will be
(a) 2:1 (b) 1:1 (c) 4:1 (d) 1:8
- Q3. If $f(x) = x + |x^2 - 8|$ then the derivative of $f(x)$ at $x=3$ is
(a) 6 (b) 7 (c) 8 (d) -8
- Q4. Given $P(A) = 1/4$, $P(B)=1/3$ and $P(A \cup B)= 1/2$. Value of $P(A/B)$ is
(a) $1/4$ (b) $1/3$ (c) $1/6$ (d) $1/7$
- Q5. The angle between two vectors $a = i+2j-k$ and $b=2i+j+k$ is
(a) 30 deg (b) 45 deg (c) 60 deg (d) 90 deg
- Q6. Newton is unit of force. It is the unit in
(a) MKS system (b) CGS system (c) FPS system (d) none of these
- Q7. A Farad is defined as
(a) stat coulomb /volt (b) coulomb/volt (c) coulomb x volt (d) stat coulomb x volt
- Q8. Permeance of a magnetic circuit corresponds to the following quantity in electrical circuit
(a) conductivity (b) resistivity (c) conductance (d) resistance
- Q9. Hydrometer is an instrument for measuring
(a) relative humidity (b) pressure of water (c) volume of liquids (d) specific gravity
- Q10. Radioactivity is a property of
(a) atomic nuclei (b) excited electron (c) gamma rays (d) ultraviolet light
- Q11. A bar of length ' L ' meters extends by ' l ' mm under a tensile force of ' P '. The strain produced in the bar is
(a) l/L (b) $0.1 l/L$ (c) $0.01 l/L$ (d) $0.001 l/L$
- Q12. A rod is enclosed centrally in a tube and the assembly is tightened by rigid washers. If the assembly is subjected to a compressive load, then
(a) rod is under compression (b) tube is under compression
(c) both rod and tube are under compression (d) tube is under tension and rod is under compression

- Q13. The shear force and bending moment are zero at the free end of a cantilever beam, if it carries a
(a) point load at the free end (b) point load at the middle of its length
(c) uniformly distributed load over the whole length (d) none of the above
- Q14. The moment of resistance of a balanced reinforced concrete beam is based on the stresses in
(a) steel only (b) concrete only (c) steel and concrete both (d) none of these
- Q15. In a flange coupling, the flanges are coupled together by means of
(a) bolts and nuts (b) studs (c) headless taper bolts (d) none of these
- Q16. A transmission shaft includes
(a) counter shaft (b) line shaft (c) over head shaft (d) all of these
- Q17. A locking device in which the bottom cylindrical portion is recessed to receive the tip of the locking set screw, is called
(a) castle nut (b) jam nut (c) ring nut (d) sawn nut
- Q18. In a venturiflume, the flow takes place at
(a) atmospheric pressure (b) gauge pressure
(c) absolute pressure (d) none of these
- Q19. The total pressure on the top of a closed cylindrical vessel completely filled up with a liquid is
(a) directly proportional to (radius)² (b) inversely proportional to (radius)²
(c) directly proportional to (radius)⁴ (d) inversely proportional to (radius)⁴
- Q20. When the Mach number is more than 6, the flow is called
(a) subsonic flow (b) sonic flow
(c) super-sonic flow (d) hyper-sonic flow
- Q21. The discharge through a convergent mouthpiece is _____ the discharge through an internal mouthpiece of the same diameter and head of water.
(a) equal to (b) one-half (c) three fourth (d) double
- Q22. Which of the following statement is wrong?
(a) The spheroidising process is usually applied to high carbon tool steels which are difficult to machine
(b) In spheroidising process, the cementite in the granular form is produced in the structure of steel
(c) The annealing process causes complete recrystallisation in steels which have been severely cold worked and a new grain structure is formed
(d) none of the above
- Q23. Duplex process of steel making is a combination of
(a) basic bessemer and acid open hearth processes
(b) acid bessemer and basic open hearth processes
(c) acid bessemer and acid open hearth processes
(d) basic bessemer and basic open hearth processes
- Q24. The property of a material necessary for forgings, in stamping images on coins and in ornamental work, is
(a) elasticity (b) plasticity (c) ductility (d) malleability

- Q25. A ladder is resting on a smooth ground and leaning against a rough vertical wall. The force of friction will act
(a) towards the wall at its upper end (b) away from the wall at its upper end
(c) downward at its upper end (d) upward at its upper end
- Q26. The slope on the road surface generally provided on the curves is known as
(a) angle of friction (b) angle of repose (c) angle of banking (d) none of these
- Q27. For any system of coplanar forces, the condition of equilibrium is that the
(a) algebraic sum of the horizontal components of all the forces should be zero
(b) algebraic sum of the vertical components of all the forces should be zero
(c) algebraic sum of moments of all the forces about any point should be zero
(d) all of the above
- Q28. An open cycle gas turbine works on
(a) Carnot cycle (b) Otto cycle (c) Joule's cycle (d) Stirling cycle
- Q29. When the gas is cooled at constant pressure,
(a) its temperature increases but volume decreases
(b) its volume increases but temperature decreases
(c) both temperature and volume increases
(d) both temperature and volume decreases
- Q30. As per Charles' law, the volume of a given mass of a perfect gas varies _____ as its absolute temperature, when the absolute pressure remains constant.
(a) directly (b) indirectly (c) no relation (d) none of the above
- Q31. In an extensive property of a thermodynamic system
(a) extensive heat is transferred (b) extensive work is done
(c) extensive energy is utilised (d) none of these
- Q32. Rotary compressors are used for delivering
(a) small quantities of air at high pressures
(b) large quantities of air at high pressures
(c) small quantities of air at low pressures
(d) large quantities of air at low pressures
- Q33. A rotary compressor is driven by an
(a) electric motor (b) engine (c) either (a) or (b) (d) none of these
- Q34. In a centrifugal compressor, an increase in speed at a given pressure ratio causes
(a) increase in flow (b) decrease in flow
(c) increase in efficiency (d) increase in flow and decrease in efficiency
- Q35. A large clearance Volume in a reciprocating compressor results in
(a) reduced volume flow rate (b) increased volume flow rate
(c) lower suction pressure (d) lower delivery pressure
- Q36. The effect of having excess camber is
(a) excessive steering alignment torque (b) hard steering
(c) too much traction (d) uneven tyre wear
- Q37. If the air-fuel mixture ignites before the spark takes place at spark plug, the condition is called
(a) detonation (b) ignition (c) pre-ignition (d) rumble

- Q38. The diagram which shows the correct crank positions corresponding to the opening and closing of the valves, is known as
 (a) indicator diagram (b) axial force diagram
 (c) valve timing diagram (d) none of these
- Q39. In value engineering, the term value refers to
 (a) manufacturing cost of the product (b) selling price of the product
 (c) total cost of the product (d) utility of the product
- Q40. Production cost refers to prime cost plus
 (a) factory overheads
 (b) factory and administration overheads
 (c) factory, administration and sales overheads
 (d) factory, administration, sales overheads and profit
- Q41. A systematic job improvement sequence will consist of
 (a) motion study (b) time study (c) job enrichment (d) all of these
- Q42. Cast iron during machining produces
 (a) continuous chips (b) discontinuous chips
 (c) continuous chips with built-up-edge (d) none of these
- Q43. A single point thread cutting tool should ideally have
 (a) zero rake angle (b) positive rake angle
 (c) negative rake angle (d) point angle
- Q44. The cutting tool in a milling machine is mounted on
 (a) spindle (b) arbor (c) column (d) knee
- Q45. One quick way to view the entire drawing area is to use the Zoom command by typing _____.
 (a) type Z enter A enter (b) type Z enter E enter
 (c) type SHOWALL enter (d) type ALL enter
- Q46. When setting up a mechanical drawing in AutoCAD the drafter should set the units to _____.
 (a) fractional (b) decimal (c) architectural (d) metric
- Q47. In a class B push-pull amplifier, the transistors are biased slightly above cut-off to avoid
 (a) crossover distortion (b) unusually high efficiency
 (c) negative feedback (d) a low input impedance
- Q48. The depletion-mode MOSFET
 (a) can operate with only positive gate voltages
 (b) can operate with only negative gate voltages
 (c) cannot operate in the ohmic region
 (d) can operate with positive as well as negative gate voltages
- Q49. Ailerons are used to control
 (a) Yaw of aircraft (b) pitch (c) roll (d) None of these
- Q50. Stalling of the aerofoil occurs
 (a) When the angle of attack is beyond critical angle of attack.
 (b) When the angle of attack is less than critical angle of attack.
 (c) Both A and B
 (d) None of the above

EKT Model Question Paper (Mechanical)-II

Instructions for Candidates**Time Allotted: 45 Minutes**

1. **Total number of Questions 50. Each Question is of three marks.**
 2. **One mark will be deducted for every wrong answer.**
 3. **No mark will be deducted for un-attempted Question.**
 4. **Do not write or make any mark on Question Paper.**
-

- Q1. One quick way to view the entire drawing area is to use the Zoom command by typing _____.
- (a) type Z enter A enter (b) type Z enter E enter
(c) type SHOWALL enter (d) type ALL enter
- Q2. When setting up a mechanical drawing in AutoCAD the drafter should set the units to _____.
- (a) fractional (b) decimal (c) architectural (d) metric
- Q3. In a class B push-pull amplifier, the transistors are biased slightly above cut-off to avoid
- (a) crossover distortion (b) unusually high efficiency
(c) negative feedback (d) a low input impedance
- Q4. The depletion-mode MOSFET
- (a) can operate with only positive gate voltages
(b) can operate with only negative gate voltages
(c) cannot operate in the ohmic region
(d) can operate with positive as well as negative gate voltages
- Q5. Ailerons are used to control
- (a) Yaw of aircraft (b) pitch (c) roll (d) None of these
- Q6. Stalling of the aerofoil occurs
- (a) When the angle of attack is beyond critical angle of attack.
(b) When the angle of attack is less than critical angle of attack.
(c) Both A and B
(d) None of the above
- Q7. As per Charles' law, the volume of a given mass of a perfect gas varies _____ as its absolute temperature, when the absolute pressure remains constant.
- (a) directly (b) indirectly (c) no relation (d) none of the above
- Q8. In an extensive property of a thermodynamic system
- (a) extensive heat is transferred (b) extensive work is done
(c) extensive energy is utilised (d) none of these
- Q9. Rotary compressors are used for delivering
- (a) small quantities of air at high pressures
(b) large quantities of air at high pressures
(c) small quantities of air at low pressures
(d) large quantities of air at low pressures
- Q10. A rotary compressor is driven by an
- (a) electric motor (b) engine (c) either (a) or (b) (d) none of these

- Q11. In a centrifugal compressor, an increase in speed at a given pressure ratio causes
(a) increase in flow (b) decrease in flow
(c) increase in efficiency (d) increase in flow and decrease in efficiency
- Q12. A large clearance Volume in a reciprocating compressor results in
(a) reduced volume flow rate (b) increased volume flow rate
(c) lower suction pressure (d) lower delivery pressure
- Q13. Newton is unit of force. It is the unit in
(a) MKS system (b) CGS system (c) FPS system (d) none of these
- Q14. A Farad is defined as
(a) stat coulomb /volt (b) coulomb/volt (c) coulomb x volt (d) stat coulomb x volt
- Q15. Permeance of a magnetic circuit corresponds to the following quantity in electrical circuit
(a) conductivity (b) resistivity (c) conductance (d) resistance
- Q16. Hydrometer is an instrument for measuring
(a) relative humidity (b) pressure of water (c) volume of liquids (d) specific gravity
- Q17. Radioactivity is a property of
(a) atomic nuclei (b) excited electron (c) gamma rays (d) ultraviolet light
- Q18. A bar of length ' L ' meters extends by ' l ' mm under a tensile force of ' P '. The strain produced in the bar is
(a) l/L (b) $0.1 l/L$ (c) $0.01 l/L$ (d) $0.001 l/L$
- Q19. A rod is enclosed centrally in a tube and the assembly is tightened by rigid washers. If the assembly is subjected to a compressive load, then
(a) rod is under compression (b) tube is under compression
(c) both rod and tube are under compression (d) tube is under tension and rod is under compression
- Q20. The shear force and bending moment are zero at the free end of a cantilever beam, if it carries a
(a) point load at the free end (b) point load at the middle of its length
(c) uniformly distributed load over the whole length (d) none of the above
- Q21. The moment of resistance of a balanced reinforced concrete beam is based on the stresses in
(a) steel only (b) concrete only (c) steel and concrete both (d) none of these
- Q22. In a flange coupling, the flanges are coupled together by means of
(a) bolts and nuts (b) studs (c) headless taper bolts (d) none of these
- Q23. A transmission shaft includes
(a) counter shaft (b) line shaft (c) over head shaft (d) all of these
- Q24. A locking device in which the bottom cylindrical portion is recessed to receive the tip of the locking set screw, is called
(a) castle nut (b) jam nut (c) ring nut (d) sawn nut
- Q25. In a venturiflume, the flow takes place at
(a) atmospheric pressure (b) gauge pressure
(c) absolute pressure (d) none of these

- Q26. The total pressure on the top of a closed cylindrical vessel completely filled up with a liquid is
(a) directly proportional to (radius)² (b) inversely proportional to (radius)²
(c) directly proportional to (radius)⁴ (d) inversely proportional to (radius)⁴
- Q27. When the Mach number is more than 6, the flow is called
(a) subsonic flow (b) sonic flow
(c) super-sonic flow (d) hyper-sonic flow
- Q28. The discharge through a convergent mouthpiece is _____ the discharge through an internal mouthpiece of the same diameter and head of water.
(a) equal to (b) one-half (c) three fourth (d) double
- Q29. Which of the following statement is wrong?
(a) The spheroidising process is usually applied to high carbon tool steels which are difficult to machine
(b) In spheroidising process, the cementite in the granular form is produced in the structure of steel
(c) The annealing process causes complete recrystallisation in steels which have been severely cold worked and a new grain structure is formed
(d) none of the above
- Q30. Duplex process of steel making is a combination of
(a) basic bessemer and acid open hearth processes
(b) acid bessemer and basic open hearth processes
(c) acid bessemer and acid open hearth processes
(d) basic bessemer and basic open hearth processes
- Q31. The property of a material necessary for forgings, in stamping images on coins and in ornamental work, is
(a) elasticity (b) plasticity (c) ductility (d) malleability
- Q32. A ladder is resting on a smooth ground and leaning against a rough vertical wall. The force of friction will act
(a) towards the wall at its upper end (b) away from the wall at its upper end
(c) downward at its upper end (d) upward at its upper end
- Q33. The slope on the road surface generally provided on the curves is known as
(a) angle of friction (b) angle of repose (c) angle of banking (d) none of these
- Q34. For any system of coplanar forces, the condition of equilibrium is that the
(a) algebraic sum of the horizontal components of all the forces should be zero
(b) algebraic sum of the vertical components of all the forces should be zero
(c) algebraic sum of moments of all the forces about any point should be zero
(d) all of the above
- Q35. An open cycle gas turbine works on
(a) Carnot cycle (b) Otto cycle (c) Joule's cycle (d) Stirling cycle
- Q36. When the gas is cooled at constant pressure,
(a) its temperature increases but volume decreases
(b) its volume increases but temperature decreases
(c) both temperature and volume increases
(d) both temperature and volume decreases

- Q37. The effect of having excess camber is
 (a) excessive steering alignment torque (b) hard steering
 (c) too much traction (d) uneven tyre wear
- Q38. If the air-fuel mixture ignites before the spark takes place at spark plug, the condition is called
 (a) detonation (b) ignition (c) pre-ignition (d) rumble
- Q39. The diagram which shows the correct crank positions corresponding to the opening and closing of the valves, is known as
 (a) indicator diagram (b) axial force diagram
 (c) valve timing diagram (d) none of these
- Q40. In value engineering, the term value refers to
 (a) manufacturing cost of the product (b) selling price of the product
 (c) total cost of the product (d) utility of the product
- Q41. Production cost refers to prime cost plus
 (a) factory overheads
 (b) factory and administration overheads
 (c) factory, administration and sales overheads
 (d) factory, administration, sales overheads and profit
- Q42. A systematic job improvement sequence will consist of
 (a) motion study (b) time study (c) job enrichment (d) all of these
- Q43. Cast iron during machining produces
 (a) continuous chips (b) discontinuous chips
 (c) continuous chips with built-up-edge (d) none of these
- Q44. A single point thread cutting tool should ideally have
 (a) zero rake angle (b) positive rake angle
 (c) negative rake angle (d) point angle
- Q45. The cutting tool in a milling machine is mounted on
 (a) spindle (b) arbor (c) column (d) knee
- Q46. If the centre of a circle is $(-6,8)$ and it passes through the origin, then equation to its tangent at the origin is
 (a) $2y = x$ (b) $4y = 3x$ (c) $3y = 4x$ (d) $3x + 4y = 0$
- Q47. The liquid is flowing separately through each of two pipes whose diameters are in the ratio of 2:1, if the ratio of the velocities of flow in the two pipes by 1:2, then the ratio of the amounts of the liquid flowing per sec through the pipe will be
 (a) 2:1 (b) 1:1 (c) 4:1 (d) 1:8
- Q48. If $f(x) = x + |x^2 - 8|$ then the derivative of $f(x)$ at $x=3$ is
 (a) 6 (b) 7 (c) 8 (d) -8
- Q49. Given $P(A) = 1/4$, $P(B)=1/3$ and $P(A \cup B)= 1/2$. Value of $P(A/B)$ is
 (a) $1/4$ (b) $1/3$ (c) $1/6$ (d) $1/7$
- Q50. The angle between two vectors $a = i+2j-k$ and $b=2i+j+k$ is
 (a) 30 deg (b) 45 deg (c) 60 deg (d) 90 deg

ANSWER KEYS: EKT Model Question
Paper (Mechanical)-I

Question Number	Answer	Question Number	Answer
1	B	26	C
2	A	27	D
3	B	28	C
4	A	29	D
5	C	30	A
6	C	31	D
7	B	32	D
8	C	33	C
9	D	34	D
10	A	35	A
11	D	36	D
12	C	37	C
13	C	38	C
14	C	39	D
15	A	40	A
16	D	41	D
17	C	42	B
18	A	43	A
19	C	44	B
20	D	45	A
21	D	46	B
22	D	47	A
23	B	48	D
24	B	49	C
25	D	50	A

**ANSWER KEY: EKT Model Question
Paper (Mechanical)-II**

Question Number	Answer	Question Number	Answer
1	A	26	C
2	B	27	D
3	A	28	D
4	D	29	D
5	C	30	B
6	A	31	B
7	A	32	D
8	D	33	C
9	D	34	D
10	C	35	C
11	D	36	D
12	A	37	D
13	C	38	C
14	B	39	C
15	C	40	D
16	D	41	A
17	A	42	D
18	D	43	B
19	C	44	A
20	C	45	B
21	C	46	B
22	A	47	A
23	D	48	B
24	C	49	A
25	A	50	C

**ANSWER KEYS: EKT Model Question Paper
(Computer Science)-I**

Question Number	Answer	Question Number	Answer
1	B	26	D
2	A	27	C
3	B	28	D
4	A	29	B
5	C	30	C
6	A	31	A
7	D	32	B
8	C	33	D
9	D	34	D
10	A	35	B
11	A	36	A
12	D	37	C
13	C	38	A
14	B	39	C
15	C	40	A
16	C	41	B
17	A	42	A
18	A	43	A
19	A	44	C
20	B	45	C
21	B	46	D
22	C	47	B
23	B	48	B
24	B	49	B
25	C	50	C

ANSWER KEYS: EKT Model Question Paper
(Computer Science)-II

Question Number	Answer	Question Number	Answer
1	A	26	C
2	D	27	A
3	C	28	B
4	B	29	D
5	C	30	D
6	B	31	B
7	A	32	A
8	C	33	A
9	A	34	C
10	C	35	C
11	A	36	D
12	C	37	B
13	A	38	B
14	A	39	B
15	A	40	C
16	B	41	B
17	B	42	A
18	C	43	B
19	B	44	A
20	B	45	C
21	C	46	D
22	D	47	A
23	C	48	C
24	D	49	A
25	B	50	D

ANSWER KEYS: EKT Model Question Paper (Electrical & Electronics)-I

Question Number	Answer	Question Number	Answer
1	C	26	C
2	A	27	D
3	B	28	D
4	B	29	A
5	A	30	B
6	D	31	B
7	D	32	B
8	B	33	B
9	B	34	B
10	D	35	C
11	D	36	D
12	A	37	A
13	B	38	A
14	C	39	B
15	C	40	A
16	C	41	A
17	C	42	A
18	B	43	A
19	A	44	B
20	D	45	C
21	C	46	C
22	B	47	C
23	C	48	D
24	A	49	C
25	D	50	A

ANSWER KEYS: EKT Model Question Paper (Electrical & Electronics)-II

Question Number	Answer	Question Number	Answer
1	B	26	B
2	B	27	A
3	C	28	D
4	C	29	D
5	B	30	A
6	A	31	B
7	D	32	C
8	C	33	C
9	B	34	A
10	C	35	A
11	A	36	A
12	D	37	B
13	C	38	C
14	D	39	C
15	D	40	C
16	A	41	D
17	B	42	C
18	B	43	A
19	B	44	C
20	B	45	A
21	B	46	B
22	C	47	B
23	D	48	A
24	A	49	D
25	A	50	D

INSTRUCTIONS FOR CANDIDATES

1. Total Number of Questions-100. Each Question is of three marks.
2. One mark will be deducted for every wrong answer.
3. No mark will be deducted for un-attempted questions.
4. Do not write on the Question Paper or make any mark on it.

Q1-3. Read the following passage carefully and answer the questions given below it:-

In spring, polar bear mothers emerge from dens with three months old cubs. The mother bear has fasted for as long as eight months but that does not stop the young from demanding full access to her remaining reserves. If there are triplets, the most persistent stands to gain an extra meal at the expense of others. The smallest of the cubs forfeits many meals to stronger siblings. Females are protective of their cubs but tend to ignore family rivalry over food. In 21 years of photographing polar bears, I have only once seen the smallest of triplets survive till autumn.

- Q1. Female polar bears give birth during
- (a) Spring
 - (b) Summer
 - (c) Autumn
 - (d) Winter
- Q2. Mother bear
- (a) Takes sides over cubs
 - (b) Lets the cubs fend for themselves
 - (c) Feeds only their favourites
 - (d) Sees that all cubs get an equal share
- Q3. With reference to the passage, the following assumptions have been made:-
- I. Polar bears fast as long as eight months due to non availability of prey.
 - II. Polar bears always give birth to triplets.
- Which of the assumptions given above is/ are true?
- (a) I only
 - (b) II only
 - (c) Both I and II
 - (d) Neither I nor II

Q4-9 Select the most appropriate word from the options against each number:-

As home entertainment, television is rapidly becoming more (4) than any other form. A news broadcast becomes more immediate when people (5) actually see the scene (6) question and the movement of the figures. Films could be viewed in the (7) of the home and a variety of shows are also available. One of the advantages of travel programmes is the (8) of faraway places which many viewers would not (9) see.

- Q4. (a) interesting (b) popular (c) powerful (d) purposeful
- Q5. (a) could (b) would (c) might (d) shall
- Q6. (a) of (b) with (c) as (d) in
- Q7. (a) surroundings (b) assistance (c) comfort (d) privilege
- Q8. (a) glimpses (b) image (c) portrait (d) picture
- Q9. (a) possible (b) rather (c) else (d) otherwise

Q10-13. Choose the word which is nearest in meaning to the given word:-

- Q10. Intransigent
- (a) Authoritative
 - (b) Impersonal
 - (c) Strenuous
 - (d) Unbending
- Q11. Intimidate
- (a) Mislead
 - (b) Misplace
 - (c) Frighten
 - (d) Demoralise
- Q12. Sporadic
- (a) Epidemic
 - (b) Whirling
 - (c) Occasional
 - (d) Stagnant
- Q13. Genesis
- (a) Style
 - (b) Beginning
 - (c) Movement
 - (d) Relevant

Q14-17. Choose the word which is nearly opposite in meaning to the given word:-

- Q14. Malevolent
 (a) Kindly (b) Vacuous (c) Ambivalent (d) Primitive
- Q15. Purgatory
 (a) Reward (b) Celestial (c) Flawless (d) Proximity
- Q16. Clemency
 (a) Corporal (b) Intolerance (c) Compromise (d) Sensibility
- Q17. Cajole
 (a) Nestle (b) Secede (c) Bully (d) Moisten

Q18-21. Choose the word that best defines the given phrases:-

- Q18. In weal and woe
 (a) By hook or crook (b) During illness
 (c) in prosperity and adversity (d) During the operation
- Q19. Globetrotters
 (a) People against global philosophy (b) People indulging in treachery
 (c) Intelligent minds (d) Travellers around the world
- Q20. A Curtain Lecture
 (a) To speak plainly (b) Vulgar Ideas
 (c) Private scolding of a husband by his wife (d) Hate others
- Q21. Square pegs in round holes
 (a) A genuinely helpful person (b) A Clever person
 (c) People in the wrong jobs (d) To be perplexed

Q22-25. Choose the correctly spelt word:-

- Q22. (a) Equanimity (b) Equannimity (c) Equanimmisty (d) Equinimity
- Q23. (a) Vetarinary (b) Vetenary (c) Veterinary (d) Vetniary
- Q24. (a) Konnoisseur (b) Conoisisseur (c) Connoisseur (d) Konoisseur
- Q25. (a) Munifisent (b) Muneficent (c) Munificent (d) Munificent

Q26-29. Which word or words explains the meaning of the following idioms:-

- Q26. In a jiffy
 (a) Outstanding (b) Suddenly (c) In a fix (d) Appropriate
- Q27. Upto the hilt
 (a) Completely (b) Upto the mark
 (c) Upto the final decision (d) None of these
- Q28. Man of Letters
 (a) Who writes too many letters (b) An important person
 (c) A politician (d) A literary person
- Q29. Sangfroid
 (a) Composure (b) Go on leave
 (c) Changed Suddenly (d) Make an attempt

Q30-65. Choose the most appropriate answer:-

- Q30. Which country among the following has been declared Ebola-free by WHO?
 (a) Sierra Leone (b) Liberia (c) Nigeria (d) Guinea
- Q31. How many Gold medals did India win in the Incheon Asian Games held in Oct 2014?
 (a) 10 (b) 11 (c) 12 (d) 8
- Q32. Who has been appointed as the new Finance Secretary of India?
 (a) Arvind Mayaram (b) Rajiv Mehrishi
 (c) Kaushik Basu (d) Dinesh Gupta

- Q33. Which among the following is India's first long range subsonic cruise missile?
 (a) Agni II (b) Prithvi (c) Dhanush (d) Nirbhay
- Q34. The branch of science that studies cells is called
 (a) Cytology (b) Entomology (c) Homoplastic (d) Hormonology
- Q35. How many Vice Presidents are elected at the start of its each regular session of UN General Assembly?
 (a) Nine (b) Fifteen (c) Two (d) Twenty one
- Q36. The highest civilian award of India 'Bharat Ratna' has been awarded to only two foreigners so far. One of them is Nelson Mandela. The other is
 (a) Marshal Tito (b) Mikhail Gorbachev
 (c) Khan Abdul Ghaffar Khan (d) Abdul Wali Khan
- Q37. Sir CV Raman was awarded Nobel Prize for his work connected with which of the following phenomenon of radiation?
 (a) Scattering (b) Diffraction (c) Interference (d) Polarisation
- Q38. In which city is the headquarters of Asian Development Bank located?
 (a) Manila (b) Singapore (c) Bangkok (d) Jakarta
- Q39. K-15 missile is
 (a) Submarine launched Ballistic Missile (SLBM)
 (b) Inter Continental Ballistic Missile (ICBM)
 (c) Medium Range Ballistic Missile (MRBM)
 (d) Short Range Ballistic Missile (SRBM)
- Q40. India agreed to UN Chief Ban Ki-Moon's offer to remain as a member of the advisory board of one of the following recently.
 (a) UNCCT (b) UNICEF (c) UNEP (d) UNCTAD
- Q41. Kaziranga National Park is famous for
 (a) One-horned Rhinos (b) Tigers
 (c) Swamp Dears (Barasingha) (d) Elephants
- Q42. Who was the first Indian to win an individual medal in Olympics?
 (a) Milkha Singh (b) PT Usha
 (c) Karnam Malleshwari (d) KD Jadhav
- Q43. Who among the following was the Congress President at Madras Session of 1927 when it boycotted the Simon Commission?
 (a) Maulana Abul Kalam Azad (b) MA Ansari
 (c) Lala Lajpat Rai (d) Subhash Chandra Bose
- Q44. Why did Kalinga prove to be a turning point in the life of Ashoka?
 (a) Ashoka annexed Kalinga
 (b) It was the starting point of the expansion of his empire
 (c) Ashoka became a zealous Buddhist
 (d) It enabled Mauryan Empire to reach its climax
- Q45. Which of the following wings was not part of the espionage system described by Kautilya?
 (a) Crime Branch (b) Special Branch
 (c) Political Branch (d) None of these
- Q46. Alauddin Khalji did not build
 (a) Siri Fort (b) Tomb of Jalaluddin
 (c) Hauz-i-Alai (d) Jamaat Khana Masjid
- Q47. Which of the following dynasties was ruling over North India at the time of Alexander's invasion?
 (a) Nanda (b) Maurya (c) Sunga (d) Kanva
- Q48. Which of the following Intercontinental Ballistic Missiles (ICBMs) is under development in India?
 (a) Agni-I (b) Agni-II (c) Agni-IV (d) Agni-VI

- Q49. Who among the following was adjudged as the Most Valuable Player of the 17th Asian Games held at Incheon, South Korea?
 (a) Mary Kom of India (b) Kosuke Hagino of Japan
 (c) Ning Zetao of China (d) None of these
- Q50. The opposition party status is accorded to a political party in the Lok Sabha only if it captures at least
 (a) 5% Seats (b) 10% Seats (c) 15% Seats (d) 20% Seats
- Q51. Who amongst the following is the author of the book 'A Bend in the River'?
 (a) Chetan Bhagat (b) VS Naipaul
 (c) Kiran Desai (d) Anita Desai
- Q52. 'Long Walk to Freedom' is a book written by
 (a) Sonia Gandhi (b) LK Advani
 (c) Nelson Mandela (d) Benazir Bhutto
- Q53. Which sports personality has been awarded the honorary rank of Group Captain by the IAF?
 (a) Kapil Dev (b) Sania Mirza
 (c) Saina Nehwal (d) Sachin Tendulkar
- Q54. A man travelled from a point A to B at the rate of 25 Kmph and walked back at the rate of 4 Kmph. If the whole journey took 5 hrs 48 minutes, the distance between A and B is
 (a) 30 Km (b) 24 Km (c) 20 Km (d) 51.6 Km
- Q55. A Train travelling at a uniform speed clears a platform 200 m long in 10 seconds and passes a telegraph post in 5 seconds. The speed of the train is
 (a) 36 km/h (b) 39 km/h (c) 72 km/h (d) 78 km/h
- Q56. The price of sugar increases by 20% due to the festive season. By what percentage should a family reduce the consumption of sugar so that there is no change in the expenditure?
 (a) 20% (b) $18\frac{1}{3}\%$ (c) $16\frac{2}{3}\%$ (d) $16\frac{1}{3}\%$
- Q57. A's salary is 20% lower than B's salary, which is 15% lower than C's salary. By how much percent is C's salary more than A's salary?
 (a) 44.05% (b) 45.05% (c) 46.05% (d) 47.05%
- Q58. The average weight of 5 men is increased by 2 Kg when one of the men whose weight is 60 Kg is replaced by a new man. The weight of the new man is
 (a) 50 Kg (b) 65 Kg (c) 68 Kg (d) 70 Kg
- Q59. A and B can do a piece of work in 18 days; B and C can do it in 24 days, A and C can do it in 36 days. In how many days B alone can finish the work?
 (a) 48 days (b) 45 days (c) $28\frac{4}{5}$ days (d) 144 days
- Q60. A, B and C can do a piece of work in 20, 30 and 60 days respectively. In how many days can A do the work if he is assisted by B and C on every third day?
 (a) 12 days (b) 15 days (c) 16 days (d) 18 days
- Q61. A man can row $9\frac{1}{3}$ Kmph in still water and finds that it takes him thrice as much time to row up than as to row down the same distance in the river. The speed of the current is
 (a) $3\frac{1}{3}$ Kmph (b) $3\frac{1}{9}$ Kmph (c) $4\frac{2}{3}$ Kmph (d) $4\frac{1}{3}$ Kmph
- Q62. The speed of a boat in still water is 10 Kmph. If it can travel 26 Km downstream and 14 Km upstream in the same time, the speed of the stream is
 (a) 2 Kmph (b) 2.5 Kmph (c) 3 Kmph (d) 4 Kmph
- Q63. If a sum becomes double in 16 years, how many times will it be in 8 years?
 (a) $1\frac{1}{2}$ times (b) $1\frac{1}{3}$ times (c) $1\frac{3}{4}$ times (d) $1\frac{1}{4}$ times

Q64. In how many years will a sum of Rs 800 at 10% per annum compounded semi-annually become Rs 926.10?

- (a) $1\frac{1}{3}$ (b) $1\frac{1}{2}$ (c) $2\frac{1}{3}$ (d) $2\frac{1}{2}$

Q65. A sells 2 TV sets, one at a loss of 15% and another at a profit of 15%. Find the loss/gain percentage in the overall transaction?

- (a) 2.25% (b) 3% (c) 4% (d) No profit, no loss

Q 66-70. Each of these questions given below contains three elements. These elements may or may not have some inter-linkage. Each group of elements may fit into one of these diagrams at (a), (b), (c) or (d). You have to indicate the group of elements which correctly fits into the diagrams.

Q66. Which of the following diagrams indicates the best relation between Doctors, Human Beings and Married People?

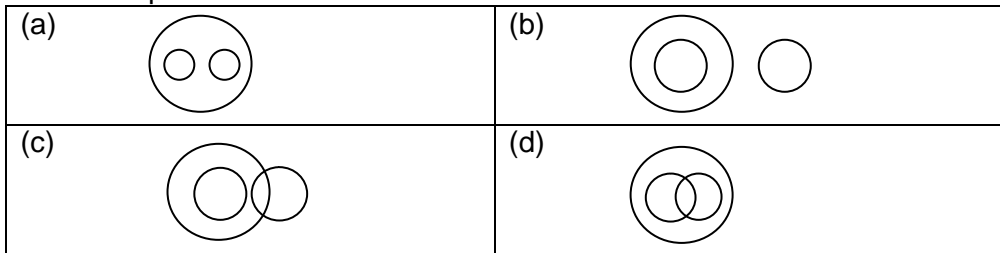

Q67. Which of the following diagrams indicates the best relation between Man, Worker and Garden?

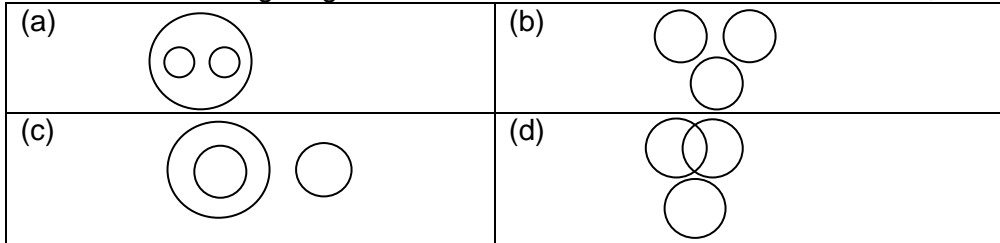

Q68. Which of the following diagrams indicates the best relation between Males, Cousins and Nephews?

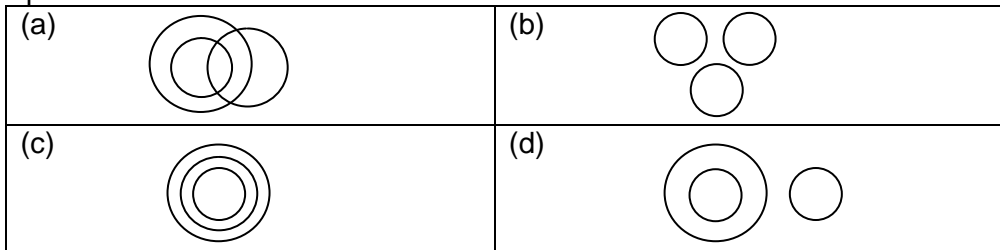

Q69. Which of the following diagrams indicates the best relation between Children, Naughty, and Studious?

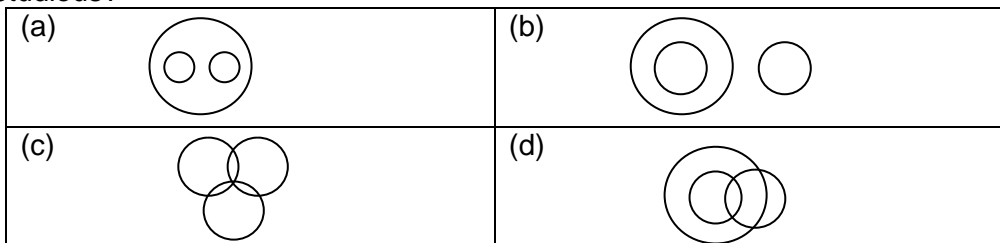

Q70. Which of the following diagrams indicates the best relation between Thief, Criminal and Police?

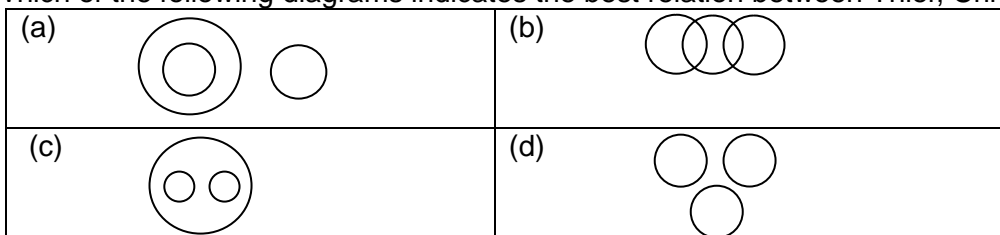

Q71-75 In each of the following questions find out the alternative which will replace the question mark.

Q71. Loath : Coercion :: ? : ?

- (a) Detest : Caressing (b) Irritate : Caressing
(c) Irate : Antagonism (d) Reluctant : Persuasion

Q72. Trilogy : Novel :: ? : ?

- (a) Rice : Husk (b) Milk : Cream
(c) Serial : Episode (d) Gun : Cartridge

Q73. Wife : Marriage :: ? : ?

- (a) Bank : Money (b) Nationality : Citizenship
(c) Service : Qualification (d) Attendance : Register

Q74. East : Orient :: ? : ?

- (a) North : Polar (b) North : Tropic
(c) South : Capricorn (d) West : Occident

Q75. Ignominy : Disloyalty :: ? : ?

- (a) Death : Victory (b) Martyr : Man
(c) Fame : Heroism (d) Destruction : Victory

Q76-80. In each of the following questions, four words have been given out of which three are alike in some manner, while the fourth one is different. Choose the word which is different from the rest.

Q76. (a) Aravalli hills (b) Shivalik hills (c) Mole hills (d) Satpura hills

Q77. (a) Beaver (b) Alpaca (c) Walrus (d) Koala

Q78. (a) Othello (b) King Lear (c) Oliver Twist (d) Macbeth

Q79. (a) Nimitz (b) Yamamoto (c) Nelson (d) Montgomery

Q80. (a) Blaze (b) Glint (c) Simmer (d) Shimmer

Q81-85. In each of the following questions, select a figure from amongst the four alternatives, which when placed in the blank space of figure (X) would complete the pattern.

Q81.

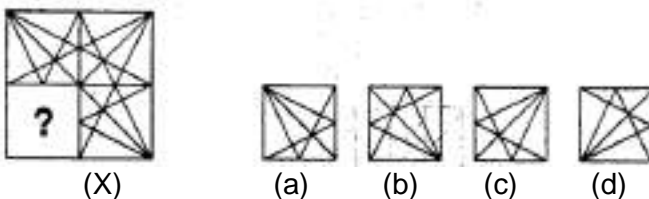

Q82.

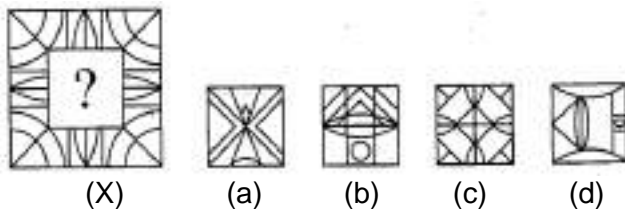

Q83.

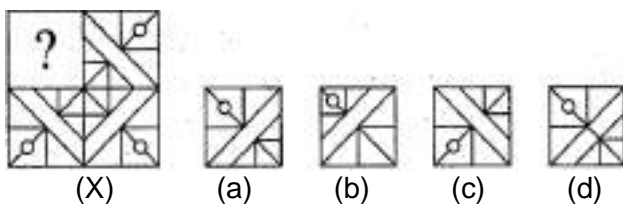

Q84.

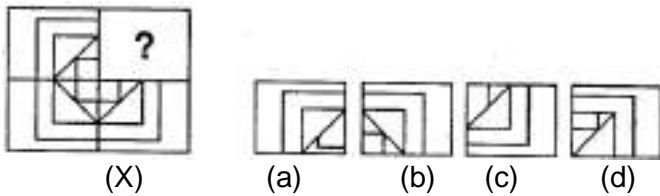

Q85.

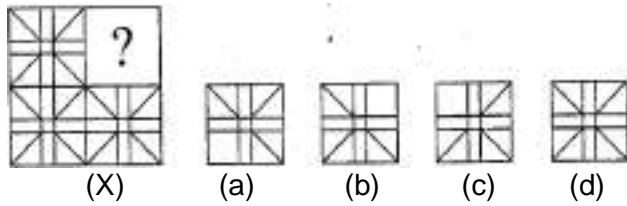

Q86-90. Each of the following questions consists of five figures marked 1,2,3,4 and 5 called the Problem Figures followed by four other figures marked a, b, c and d called the Answer Figures. Select a figure from amongst the Answer Figures which will continue the same series as established by the five Problem Figures.

Q86.



Q87.

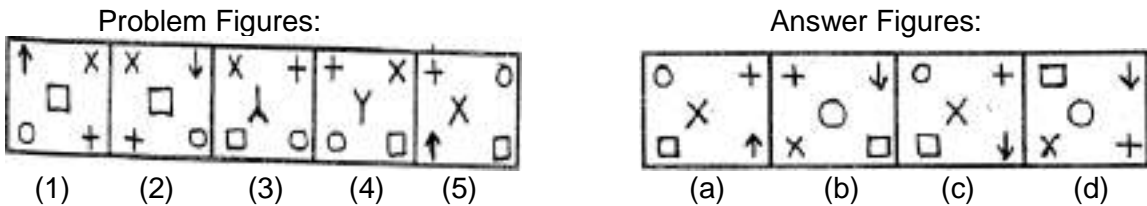

Q88.

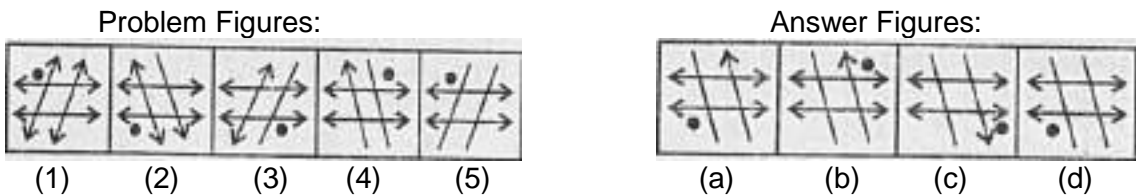

Q89.

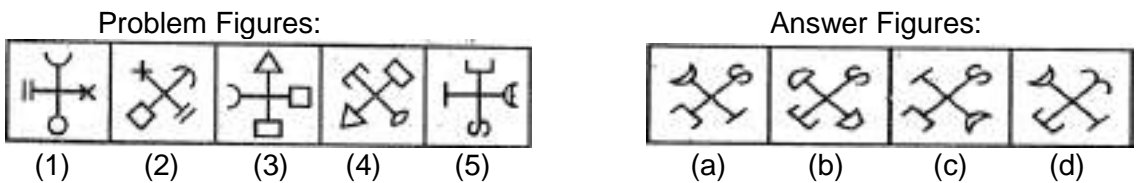

Q90.

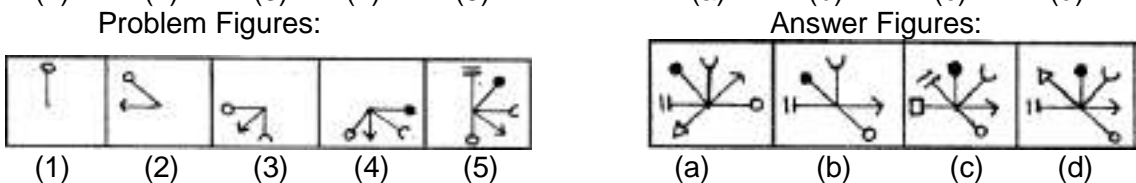

Q91-95. Each of the following questions consists of two sets of figures. Figures 1, 2, 3 and 4 constitute the Problem Set while figures a, b, c and d constitute the Answer Set. There is a definite relationship between figures (1) and (2). Establish a similar relationship between figures (3) and (4) by selecting a suitable figure from the Answer set that would replace the question mark (?) in fig.(4).

Q91.

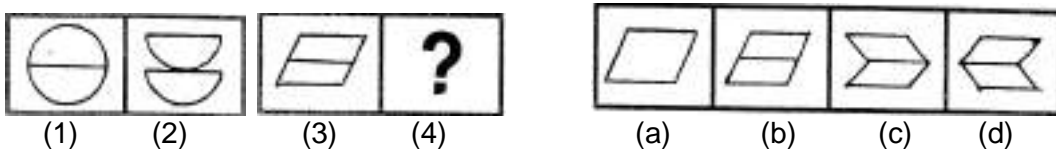

Q92.

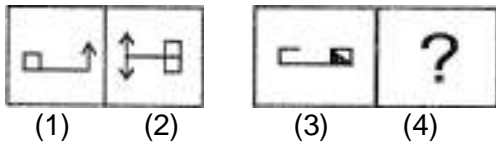

Q93.

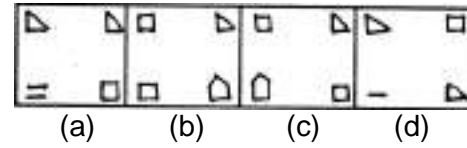
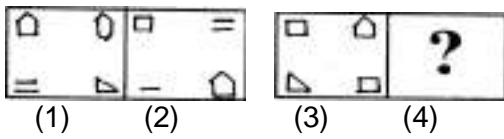

Q94.

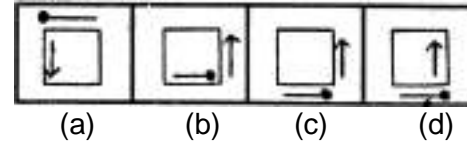
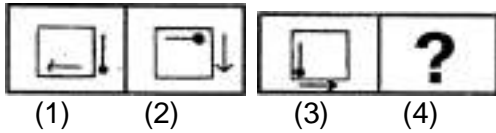

Q95.

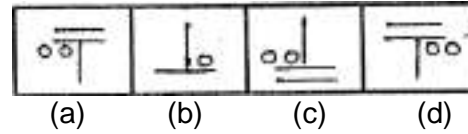
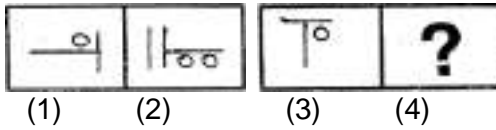

Q96-100. In each problem, out of the four figures marked (a) (b) (c) and (d) three are similar in a certain manner. However, one figure is not like the other three. Choose the figure which is different from the rest.

Q96.

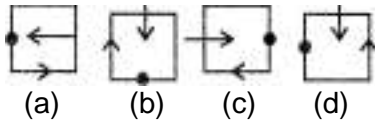

Q97.

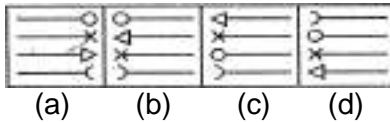

Q98.

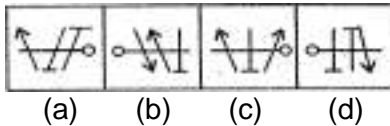

Q99.

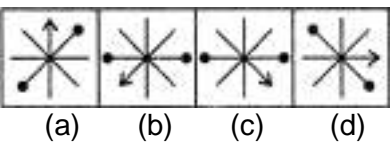

Q100.

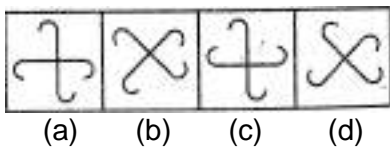

TIME ALLOTTED – 2HRS

INSTRUCTIONS FOR CANDIDATES

1. Total Number of Questions-100. Each Question is of three marks.
2. One mark will be deducted for every wrong answer.
3. No mark will be deducted for un-attempted questions.
4. Do not write on the Question Paper or make any mark on it.

Q1-4. Which word or words explains the meaning of the following idioms:-

- Q1. In a jiffy
 (a) Outstanding (b) Suddenly (c) In a fix (d) Appropriate
- Q2. Upto the hilt
 (a) Completely (b) Upto the mark
 (c) Upto the final decision (d) None of these
- Q3. Man of Letters
 (a) Who writes too many letters (b) An important person
 (c) A politician (d) A literary person
- Q4. Sangfroid
 (a) Composure (b) Go on leave
 (c) Changed Suddenly (d) Make an attempt

Q5-10 Select the most appropriate word from the options against each number:-

As home entertainment, television is rapidly becoming more (5) than any other form. A news broadcast becomes more immediate when people (6) actually see the scene (7) question and the movement of the figures. Films could be viewed in the (8) of the home and a variety of shows are also available. One of the advantages of travel programmes is the (9) of faraway places which many viewers would not (10) see.

- Q5. (a) interesting (b) popular (c) powerful (d) purposeful
- Q6. (a) could (b) would (c) might (d) shall
- Q7. (a) of (b) with (c) as (d) in
- Q8. (a) surroundings (b) assistance (c) comfort (d) privilege
- Q9. (a) glimpses (b) image (c) portrait (d) picture
- Q10. (a) possible (b) rather (c) else (d) otherwise

Q11-14. Choose the word which is nearest in meaning to the given word:-

- Q11. Sporadic
 (a) Epidemic (b) Whirling (c) Occasional (d) Stagnant
- Q12. Genesis
 (a) Style (b) Beginning (c) Movement (d) Relevant
- Q13. Intransigent
 (a) Authoritative (b) Impersonal (c) Strenuous (d) Unbending
- Q14. Intimidate
 (a) Mislead (b) Misplace (c) Frighten (d) Demoralise

Q15-18. Choose the word which is nearly opposite in meaning to the given word:-

- Q15. Clemency
 (a) Corporal (b) Intolerance (c) Compromise (d) Sensibility
- Q16. Cajole
 (a) Nestle (b) Secede (c) Bully (d) Moisten

Q17. Malevolent
 (a) Kindly (b) Vacuous (c) Ambivalent (d) Primitive

Q18. Purgatory
 (a) Reward (b) Celestial (c) Flawless (d) Proximity

Q19-21. Read the following passage carefully and answer the questions given below it:-

In spring, polar bear mothers emerge from dens with three months old cubs. The mother bear has fasted for as long as eight months but that does not stop the young from demanding full access to her remaining reserves. If there are triplets, the most persistent stands to gain an extra meal at the expense of others. The smallest of the cubs forfeits many meals to stronger siblings. Females are protective of their cubs but tend to ignore family rivalry over food. In 21 years of photographing polar bears, I have only once seen the smallest of triplets survive till autumn.

Q19. With reference to the passage, the following assumptions have been made:-

I. Polar bears fast as long as eight months due to non availability of prey.

II. Polar bears always give birth to triplets.

Which of the assumptions given above is/ are true?

(a) I only (b) II only (c) Both I and II (d) Neither I nor II

Q20. Female polar bears give birth during

- (a) Spring
 (b) Summer
 (c) Autumn
 (d) Winter

Q21. Mother bear

- (a) Takes sides over cubs
 (b) Lets the cubs fend for themselves
 (c) Feeds only their favourites
 (d) Sees that all cubs get an equal share

Q22-25. Choose the word that best defines the given phrases:-

Q22. A Curtain Lecture

- (a) To speak plainly (b) Vulgar Ideas
 (c) Private scolding of a husband by his wife (d) Hate others

Q23. Square pegs in round holes

- (a) A genuinely helpful person (b) A Clever person
 (c) People in the wrong jobs (d) To be perplexed

Q24. In weal and woe

- (a) By hook or crook (b) During illness
 (c) in prosperity and adversity (d) During the operation

Q25. Globetrotters

- (a) People against global philosophy (b) People indulging in treachery
 (c) Intelligent minds (d) Travellers around the world

Q26-29. Choose the correctly spelt word:-

Q26. (a) Konnoisseur (b) Conoisisseur (c) Connoisseur (d) Konoisseur

Q27. (a) Munifisent (b) Muneficent (c) Munificent (d) Munificent

Q28. (a) Equanimity (b) Equannimity (c) Equanimmisty (d) Equinimity

Q29. (a) Vetarinary (b) Vetenary (c) Veterinary (d) Vetniary

Q30-65. Choose the most appropriate answer:-

Q30. A, B and C can do a piece of work in 20, 30 and 60 days respectively. In how many days can A do the work if he is assisted by B and C on every third day?

- (a) 12 days (b) 15 days (c) 16 days (d) 18 days

- Q31. A man can row $9\frac{1}{3}$ Kmph in still water and finds that it takes him thrice as much time to row up than as to row down the same distance in the river. The speed of the current is
 (a) $3\frac{1}{3}$ Kmph (b) $3\frac{1}{9}$ Kmph (c) $4\frac{2}{3}$ Kmph (d) $4\frac{1}{3}$ Kmph
- Q32. The speed of a boat in still water is 10 Kmph. If it can travel 26 Km downstream and 14 Km upstream in the same time, the speed of the stream is
 (a) 2 Kmph (b) 2.5 Kmph (c) 3 Kmph (d) 4 Kmph
- Q33. If a sum becomes double in 16 years, how many times will it be in 8 years?
 (a) $1\frac{1}{2}$ times (b) $1\frac{1}{3}$ times (c) $1\frac{3}{4}$ times (d) $1\frac{1}{4}$ times
- Q34. In how many years will a sum of Rs 800 at 10% per annum compounded semi-annually become Rs 926.10?
 (a) $1\frac{1}{3}$ (b) $1\frac{1}{2}$ (c) $2\frac{1}{3}$ (d) $2\frac{1}{2}$
- Q35. A sells 2 TV sets, one at a loss of 15% and another at a profit of 15%. Find the loss/gain percentage in the overall transaction?
 (a) 2.25% (b) 3% (c) 4% (d) No profit, no loss
- Q36. A man travelled from a point A to B at the rate of 25 Kmph and walked back at the rate of 4 Kmph. If the whole journey took 5 hrs 48 minutes, the distance between A and B is
 (a) 30 Km (b) 24 Km (c) 20 Km (d) 51.6 Km
- Q37. A Train travelling at a uniform speed clears a platform 200 m long in 10 seconds and passes a telegraph post in 5 seconds. The speed of the train is
 (a) 36 km/h (b) 39 km/h (c) 72 km/h (d) 78 km/h
- Q38. The price of sugar increases by 20% due to the festive season. By what percentage should a family reduce the consumption of sugar so that there is no change in the expenditure?
 (a) 20% (b) $18\frac{1}{3}\%$ (c) $16\frac{2}{3}\%$ (d) $16\frac{1}{3}\%$
- Q39. A's salary is 20% lower than B's salary, which is 15% lower than C's salary. By how much percent is C's salary more than A's salary?
 (a) 44.05% (b) 45.05% (c) 46.05% (d) 47.05%
- Q40. The average weight of 5 men is increased by 2 Kg when one of the men whose weight is 60 Kg is replaced by a new man. The weight of the new man is
 (a) 50 Kg (b) 65 Kg (c) 68 Kg (d) 70 Kg
- Q41. A and B can do a piece of work in 18 days; B and C can do it in 24 days, A and C can do it in 36 days. In how many days B alone can finish the work?
 (a) 48 days (b) 45 days (c) $28\frac{4}{5}$ days (d) 144 days
- Q42. The opposition party status is accorded to a political party in the Lok Sabha only if it captures at least
 (a) 5% Seats (b) 10% Seats (c) 15% Seats (d) 20% Seats
- Q43. Who amongst the following is the author of the book 'A Bend in the River'?
 (a) Chetan Bhagat (b) VS Naipaul
 (c) Kiran Desai (d) Anita Desai
- Q44. 'Long Walk to Freedom' is a book written by
 (a) Sonia Gandhi (b) LK Advani
 (c) Nelson Mandela (d) Benazir Bhutto
- Q45. Which sports personality has been awarded the honorary rank of Group Captain by the IAF?
 (a) Kapil Dev (b) Sania Mirza
 (c) Saina Nehwal (d) Sachin Tendulkar

- Q46. Which country among the following has been declared Ebola-free by WHO?
 (a) Sierra Leone (b) Liberia (c) Nigeria (d) Guinea
- Q47. How many Gold medals did India win in the Incheon Asian Games held in Oct 2014?
 (a) 10 (b) 11 (c) 12 (d) 8
- Q48. Who has been appointed as the new Finance Secretary of India?
 (a) Arvind Mayaram (b) Rajiv Mehrishi
 (c) Kaushik Basu (d) Dinesh Gupta
- Q49. Which among the following is India's first long range subsonic cruise missile?
 (a) Agni II (b) Prithvi (c) Dhanush (d) Nirbhay
- Q50. The branch of science that studies cells is called
 (a) Cytology (b) Entomology (c) Homoplastic (d) Hormonology
- Q51. How many Vice Presidents are elected at the start of its each regular session of UN General Assembly?
 (a) Nine (b) Fifteen (c) Two (d) Twenty one
- Q52. The highest civilian award of India 'Bharat Ratna' has been awarded to only two foreigners so far. One of them is Nelson Mandela. The other is
 (a) Marshal Tito (b) Mikhail Gorbachev
 (c) Khan Abdul Ghaffar Khan (d) Abdul Wali Khan
- Q53. Sir CV Raman was awarded Nobel Prize for his work connected with which of the following phenomenon of radiation?
 (a) Scattering (b) Diffraction (c) Interference (d) Polarisation
- Q54. In which city is headquarters of Asian Development Bank located?
 (a) Manila (b) Singapore (c) Bangkok (d) Jakarta
- Q55. K-15 missile is
 (a) Submarine launched Ballistic Missile (SLBM)
 (b) Inter Continental Ballistic Missile (ICBM)
 (c) Medium Range Ballistic Missile (MRBM)
 (d) Short Range Ballistic Missile (SRBM)
- Q56. India agreed to UN Chief Ban Ki-Moon's offer to remain as a member of the advisory board of one of the following recently.
 (a) UNCCT (b) UNICEF (c) UNEP (d) UNCTAD
- Q57. Kaziranga National Park is famous for
 (a) One-horned Rhinos (b) Tigers
 (c) Swamp Dears (Barasingha) (d) Elephants
- Q58. Who was the first Indian to win an individual medal in Olympics?
 (a) Milkha Singh (b) PT Usha
 (c) Karnam Malleshwari (d) KD Jadhav
- Q59. Who among the following was the Congress President at Madras Session of 1927 when it boycotted the Simon Commission?
 (a) Maulana Abul Kalam Azad (b) MA Ansari
 (c) Lala Lajpat Rai (d) Subhash Chandra Bose
- Q60. Why did Kalinga prove to be a turning point in the life of Ashoka?
 (a) Ashoka annexed Kalinga
 (b) It was the starting point of the expansion of his empire
 (c) Ashoka became a zealous Buddhist
 (d) It enabled Mauryan Empire to reach its climax
- Q61. Which of the following wings was not part of the espionage system described by Kautilya?
 (a) Crime Branch (b) Special Branch
 (c) Political Branch (d) None of these

- Q62. Alauddin Khalji did not build
 (a) Siri Fort (b) Tomb of Jalaluddin
 (c) Hauz-i-Alai (d) Jamaat Khana Masjid
- Q63. Which of the following dynasties was ruling over North India at the time of Alexander's invasion?
 (a) Nanda (b) Maurya (c) Sunga (d) Kanva
- Q64. Which of the following Intercontinental Ballistic Missiles (ICBMs) is under development in India?
 (a) Agni-I (b) Agni-II (c) Agni-IV (d) Agni-VI
- Q65. Who among the following was adjudged as the Most Valuable Player of the 17th Asian Games held at Incheon, South Korea?
 (a) Mary Kom of India (b) Kosuke Hagino of Japan
 (c) Ning Zetao of China (d) None of these

Q66-70 In each of the following questions find out the alternative which will replace the question mark.

- Q66. East : Orient :: ??
 (a) North : Polar (b) North : Tropic
 (c) South : Capricorn (d) West : Occident
- Q67. Ignominy : Disloyalty :: ??
 (a) Death : Victory (b) Martyr : Man
 (c) Fame : Heroism (d) Destruction : Victory
- Q68. Loath : Coercion :: ??
 (a) Detest : Caressing (b) Irritate : Caressing
 (c) Irate : Antagonism (d) Reluctant : Persuasion
- Q69. Trilogy : Novel :: ??
 (a) Rice : Husk (b) Milk : Cream
 (c) Serial : Episode (d) Gun : Cartridge
- Q70. Wife : Marriage :: ??
 (a) Bank : Money (b) Nationality : Citizenship
 (c) Service : Qualification (d) Attendance : Register

Q 71-75. Each of these questions given below contains three elements. These elements may or may not have some inter-linkage. Each group of elements may fit into one of these diagrams at (a), (b), (c) or (d). You have to indicate the group of elements which correctly fits into the diagrams.

- Q71. Which of the following diagrams indicates the best relation between Doctors, Human Beings and Married People?

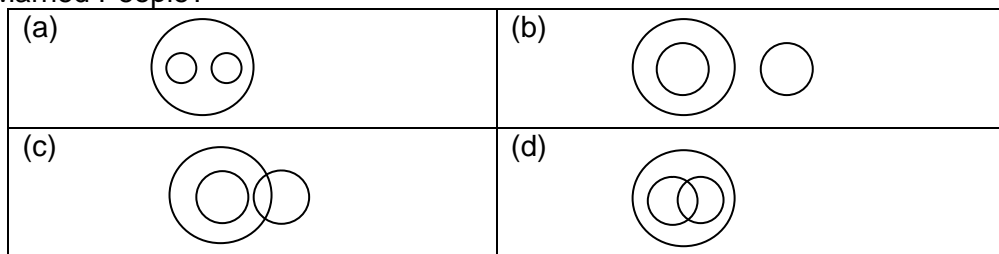

- Q72. Which of the following diagrams indicates the best relation between Children, Naughty, and Studious?

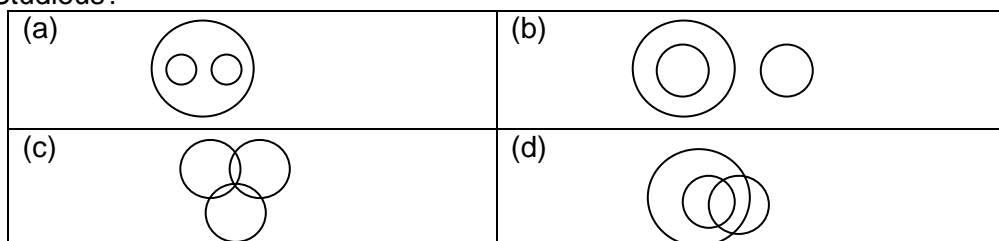

Q73. Which of the following diagrams indicates the best relation between Thief, Criminal and Police?

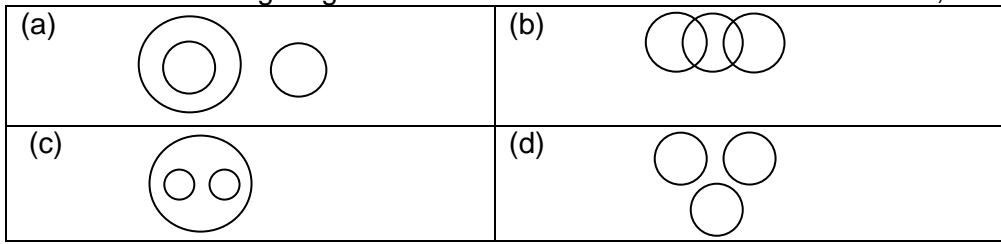

Q74. Which of the following diagrams indicates the best relation between Man, Worker and Garden?

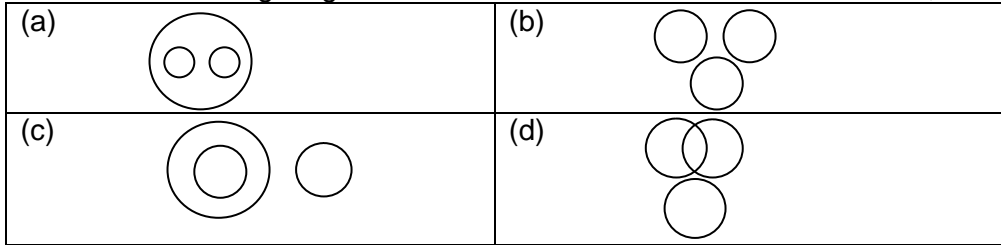

Q75. Which of the following diagrams indicates the best relation between Males, Cousins and Nephews?

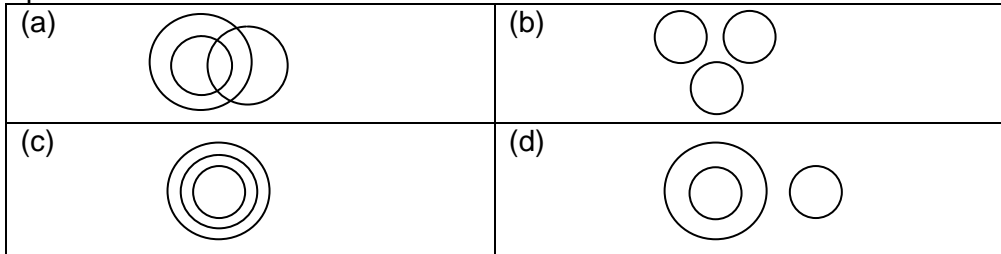

Q76-80. In each of the following questions, select a figure from amongst the four alternatives, which when placed in the blank space of figure (X) would complete the pattern.

Q76.

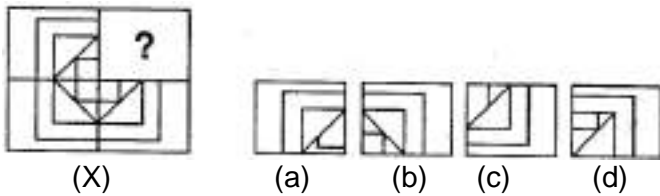

Q77.

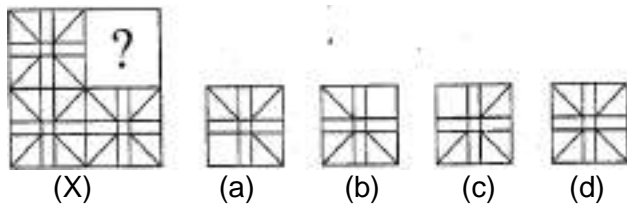

Q78.

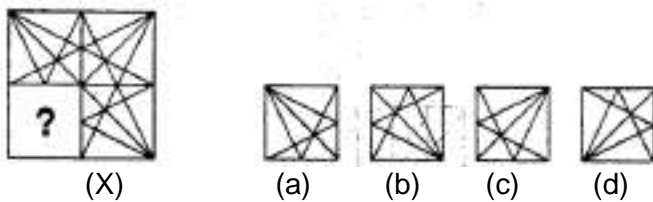

Q79.

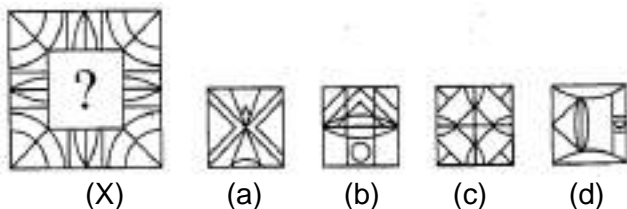

Q80.

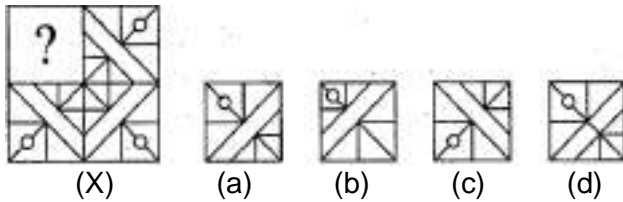

Q81-85. Each of the following questions consists of five figures marked 1,2,3,4 and 5 called the **Problem Figures** followed by four other figures marked a, b, c and d called the **Answer Figures**. Select a figure from amongst the **Answer Figures** which will continue the same series as established by the five **Problem Figures**.

Q81.

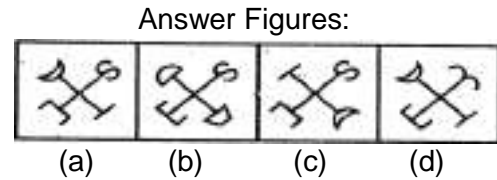
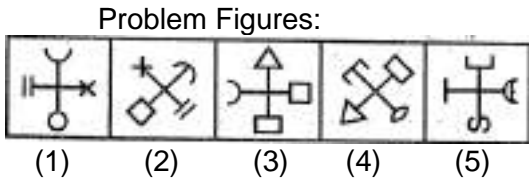

Q82.

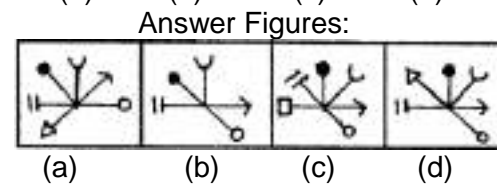
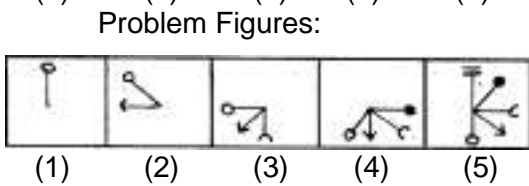

Q83.

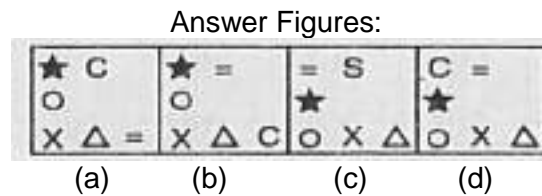
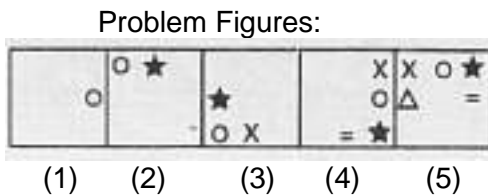

Q84.

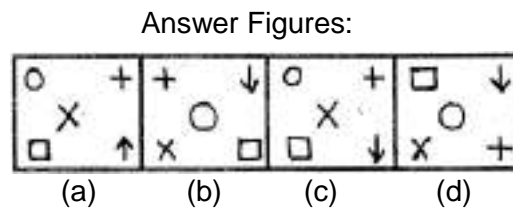
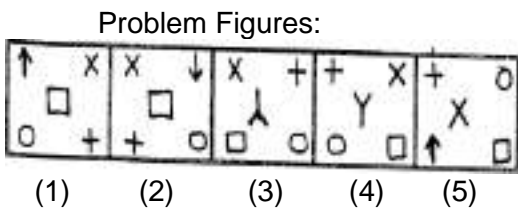

Q85.

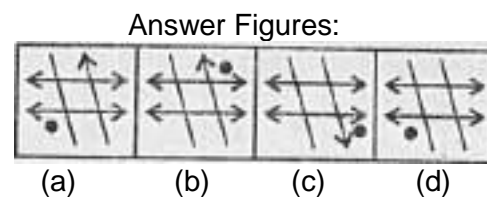
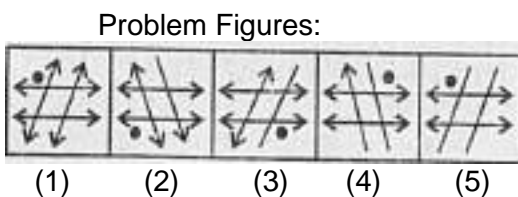

Q86-90. In each of the following questions, four words have been given out of which three are alike in some manner, while the fourth one is different. Choose the word which is different from the rest.

Q86. (a) Othello (b) King Lear (c) Oliver Twist (d) Macbeth

Q87. (a) Nimitz (b) Yamamoto (c) Nelson (d) Montgomery

Q88. (a) Blaze (b) Glint (c) Simmer (d) Shimmer

Q89. (a) Aravalli hills (b) Shivalik hills (c) Mole hills (d) Satpura hills

Q90. (a) Beaver (b) Alpaca (c) Walrus (d) Koala

Q91-95. In each problem, out of the four figures marked (a) (b) (c) and (d) three are similar in a certain manner. However, one figure is not like the other three. Choose the figure which is different from the rest.

Q91.

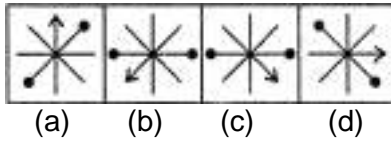

Q92.

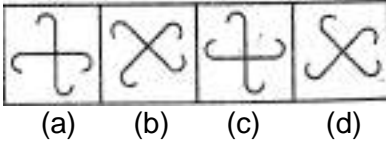

Q93.

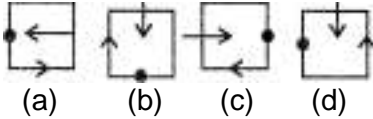

Q94.

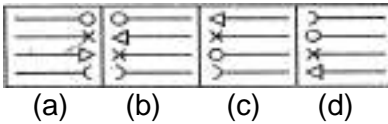

Q95.

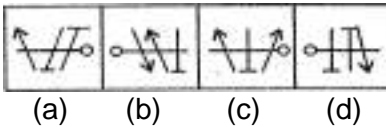

Q96-100. Each of the following questions consists of two sets of figures. Figures 1, 2, 3 and 4 constitute the Problem Set while figures a, b, c and d constitute the Answer Set. There is a definite relationship between figures (1) and (2). Establish a similar relationship between figures (3) and (4) by selecting a suitable figure from the Answer set that would replace the question mark (?) in fig.(4).

Q96.

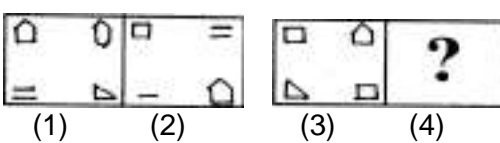

Q97.

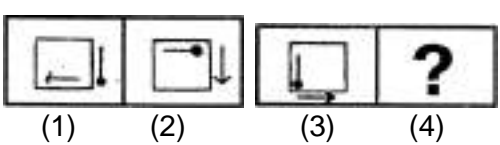

Q98.

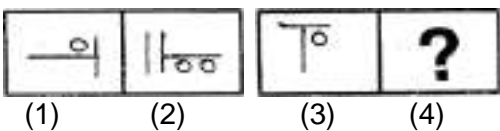

Q99.

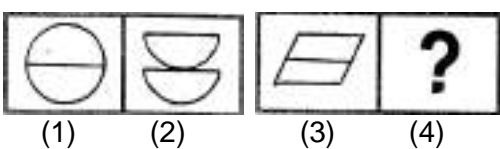

Q100.

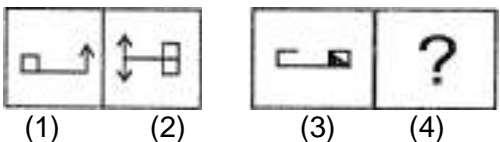

INSTRUCTIONS FOR CANDIDATES

1. Total No Of Questions-100. Each Question is of three marks.
2. One mark will be deducted for every wrong answer.
3. No mark will be deducted for un-attempted questions.
4. Do not write on the Question Paper or make any mark on it.

Q1-3. Read the following passage carefully and answer the questions given below it:-

Recently, a newspaper article mourned the total disappearance of the common house sparrow. This was a comment on the city's perceptible move towards edging out the flora and fauna of the city. In the rapid urbanization, multi-storied apartments grew and large scale felling of trees became necessary. Last week, however, seven pairs of these sparrows were spotted in a suburb. Possibly the greenery of this place has created a new habitat for these birds which like their proximity to human beings, and have made a comeback. A systematic development of trees and shrubs all over the city could woo the absentee house sparrow to our midst.

- Q1. In the passage the term "urbanisation" has been used to refer to
- (a) the destruction of the greenery in the city
 - (b) construction of concrete structures on a large scale
 - (c) a change over from the rural life to the city life
 - (d) the movement of people from villages to cities
- Q2. The phrase "absentee house sparrow" refers to
- (a) the sparrow that makes infrequent visits
 - (b) the sparrow that has forgotten its habitat
 - (c) the sparrow that has gone away from the urban areas
 - (d) the sparrow that has become extinct
- Q3. According to the passage, the birds have made a comeback to the suburb because they
- (a) have been hunted down by the village people
 - (b) Love to be amidst human beings
 - (c) get food only where human beings live
 - (d) they have been deliberately brought back by biologists

Q4-9 Select the most appropriate word from the options against each number:-

Watermelons ..(4).. to India by the 4th century A.D. Sushruta, the great Indian physician,(5)...wrote Sushruta Samhit, mentions that watermelons were grown ..(6).. the banks of the river Indus.(7)...are also mentioned in ancient books. Sushruta calls it as Kalinda or Kalinga (hence Kalingad in Marathi). It was...(8)..to China in the 10th or 11th century and ...(9)... it is grown throughout the tropics.

- Q4. (a) came (b) go (c) arrived (d) started
- Q5. (a) did (b) when (c) certainly (d) who
- Q6. (a) above (b) outside (c) from (d) along
- Q7. (a) it (b) they (c) some (d) that
- Q8. (a) took (b) gave (c) taken (d) take
- Q9. (a) also (b) though (c) now (d) tomorrow

Q10-13. Choose the word which is nearest in meaning to the given word:-

- Q10. Embellish
- (a) Employ
 - (b) Arrange
 - (c) Decorate
 - (d) Design
- Q11. Damp Squib
- (a) Insignificant happening
 - (b) An old technique
 - (c) Unsuccessful attempt
 - (d) Short, shrill cry

Q12. Sagacious
 (a) Stupid (b) Truthful (c) Lustful (d) Discerning

Q13. Pontificate
 (a) To speak authoritatively (b) To raise to higher office
 (c) To act clumsily (d) To constitute

Q14-17. Choose the word which is nearly opposite in meaning to the given word:-

Q14. Parsimonious
 (a) Generous (b) Selfish (c) Religious (d) Hereditary

Q15. Vindicate
 (a) Censure (b) Favour (c) Indicate (d) Eradicate

Q16. Sporadic
 (a) Rare (b) Frequent (c) Sharp (d) Coordinated

Q17. Exonerate
 (a) Reject (b) Contract (c) Accuse (d) Admit

Q18-21. Choose the word that best defines the given phrases:-

Q18. Cloak and dagger
 (a) To fight to a finish (b) To get into unexpected trouble
 (c) To end the hostility (d) Like a spy

Q19. To be at the end of one's tether
 (a) To feel offended (b) To draw moral attention
 (c) To have no resources left (d) To think deeply

Q20. All agog
 (a) Work helplessly (b) Lose consciousness
 (c) In a state of excitement (d) Fall flat

Q21. Espirit de Corps
 (a) Bravery (b) Loyalty (c) Subordination (d) Unity

Q22-25. Choose the correctly spelt word:-

Q22. (a) Omminous (b) Omineous (c) Ominous (d) Omenous

Q23. (a) Hindrance (b) Hinderance (c) Hindrence (d) Hinderence

Q24. (a) Perjery (b) Perjury (c) Purjury (d) Perjary

Q25. (a) Reminiscene (b) Reminiscence (c) Reminicence (d) Remeniscence

Q26-29. Which word or words explains the meaning of the following idioms:-

Q26. A blue stocking
 (a) Stocking which is blue in colour (b) A clean cheat
 (c) An unreliable person (d) a woman having literary tastes and learning

Q27. Yeoman's service
 (a) lip-service (b) to serve like a slave
 (c) to play god father (d) efficient or useful help

Q28. Lay bare
 (a) Expose (b) Take off all clothes
 (c) Destroy (d) Exploit

Q29. A wolf in sheep's clothing
 (a) A hypocrite (b) A wolf in woolen clothes
 (c) A coward (d) A proud man

Q30-65. Choose the most appropriate answer:-

- Q30. The national emblem, viz four lions standing back to back is an adaptation from which of the following:-
 (a) Sarnath lions (b) Gir lions
 (c) Khajurao (d) Ajanta caves
- Q31. Who among the following is not a recipient of the 'Bharatiya Jnanpith' Award?
 (a) Ashapurna Devi (b) MF Hussain
 (c) Raghupati Sahay (d) VK Gokak
- Q32. Global 500 awards are given for outstanding achievement in which of the following fields?
 (a) Population Control (b) Elimination of illiteracy
 (c) Campaigning against AIDS (d) Protection of environment
- Q33. Pulitzer Prize is awarded for the outstanding work in the field of
 (a) Science and Technology (b) Environmental Studies
 (c) Literature and Journalism (d) International Understanding
- Q34. Who was the founder of Nanda dynasty?
 (a) Bimbisara (b) Mahapadma Nanda
 (c) Ajatasatru (d) Dhana Nanda
- Q35. Which of the following books is written by Arnold Toynbee?
 (a) Mankind and Mother Earth (b) Tom Sawyer
 (c) The Future of Freedom (d) The Moon's Last Sigh
- Q36. The presidency of the UN Security Council rotates among the Council Members
 (a) Every 6 months (b) Every year
 (c) Every 3 months (d) Every month
- Q37. Who were the contemporaries of the Gupta Kings in the south?
 (a) Chola (b) Rashtrakutas
 (c) Satavahanas (d) Vakatkas
- Q38. Who was the person behind conversion of East India Company from a trading company into a regional power?
 (a) Lord Warren Hastings (b) Lord Clive
 (c) Lord Dalhousie (d) Lord Wellesley
- Q39. Who inscribed the name of Khalifa of Baghdad on his coins?
 (a) Ala-ud-din Khilji (b) Iltutmish
 (c) Qutub-ud-in Aibak (d) Balban
- Q40. Who among the following Sultans of Delhi assumed the title, 'Sikandar-i-Sani'?
 (a) Balban (b) Ala-ud-din Khilji
 (c) Muhammad-bin-Tughlaq (d) Sikander Lodhi
- Q41. UN General Assembly recently declared 21st June as
 (a) International Youth Day (b) International Literacy Day
 (c) International Day of Yoga (d) International Day of Peace
- Q42. The member countries of NAFTA are
 (a) USA, Canada and Mexico (b) Canada and Mexico
 (c) USA and Canada (d) Argentina and Brazil
- Q43. Sandeep Sejwal won the Bronze medal in 2014 Asian Games in which of the following events?
 (a) 200m backstroke (b) 200m freestyle
 (c) 50m breaststroke (d) 50m butterfly
- Q44. The Indian space programme began in
 (a) 1961 (b) 1962 (c) 1965 (d) 1969

- Q45. 'Bachpan Bachao Andolan (BBA)', an organisation to protect the rights of children was founded by
 (a) Amir Khan (b) Kailash Satyarthi
 (c) Om Prakash Gurjar (d) Santa Sinha
- Q46. Mangalyan, Mars Orbiter Mission (MOM) was launched in
 (a) Jan 2013 (b) Oct 2012 (c) Oct 2013 (d) Nov 2013
- Q47. "Ruhr of India" known for its rich coal deposits is in the State of
 (a) Uttar Pradesh (b) Jharkhand (c) West Bengal (d) Bihar
- Q48. Which of the following Subsonic missiles, test fired in October 2014 is considered India's answer to America's Tomahawk missile
 (a) Brahmos Mk-2 (b) Prahaar (c) Nirbhay (d) Agni-V
- Q49. Who among the following won the World Billiards Championship held in England in October 2014?
 (a) Peter Gilchrist (b) Pankaj Advani
 (c) Saurav Kothari (d) None of these
- Q50. Which country will host the XXXI Olympic Games in 2016?
 (a) Rio de Janeiro, Brazil (b) Chicago, USA
 (c) Tokyo, Japan (d) Doha, Qatar
- Q51. The book, "A China Passage" was written by
 (a) MJ Akbar (b) Jagmohan
 (c) Anees Jung (d) John Kenneth Galbraith
- Q52. A can do a piece of work in 20 days and B in 25 days. They work together for 5 days and then B goes away. In how many days will A finish the work?
 (a) 11 days (b) 9 days (c) 20 days (d) 21 days
- Q53. Two train A & B each 66 meters long run parallel to each other in the same direction. Their speeds are 50 Kmph and 30 Kmph respectively. In what time A will completely pass B.
 (a) 28 Sec (b) 28.46 Sec (c) 53.46 Sec (d) 23.76 Sec
- Q54. A train 77.5 m in length is running at the rate of 65 Kmph. Find the time taken by the train to pass the man walking in the same direction as the train @ 3 Kmph.
 (a) 2.5 Sec (b) 4.5 Sec (c) 6.5 Sec (d) 8 Sec
- Q55. Ram can row $7\frac{1}{2}$ Kmph in still water. If in a river running at 1.5 Km an hour, it takes him 50 minutes to row to a place and back, how far is the place?
 (a) 3.5 Km (b) 3 Km (c) 4.5 Km (d) 5 Km
- Q56. A motorboat with speed 15 Kmph in still water goes 30 Km downstream and comes back. It covers the distance in 4 hours and 30 minutes. The speed of the stream in Km/h is?
 (a) 4 (b) 5 (c) 6 (d) 10
- Q57. Zinc and copper are melted together in the ratio 9:11. What is the weight of the melted mixture, if 28.8 kg of zinc has been consumed in it?
 (a) 58 Kg (b) 60 Kg (c) 64 Kg (d) 70 Kg
- Q58. A sells his goods 20% cheaper than B and 20% dearer than C. How much percentage is C's goods cheaper / dearer than B.
 (a) 33.33% (b) 50% (c) 45.85% (d) None of these
- Q59. The average of 6 observations is 12. If the 7th observation is included, the average is reduced by 1. What will be the 7th observation?
 (a) 4 (b) 5 (c) 6 (d) 7
- Q60. If the incomes of Ram & Shyam are in the ratio of 3:4 and their expenditures in the ratio of 4:5, find the ratio of their savings, given that Shyam saves a third of his income.
 (a) 10:15 (b) 13:20 (c) 15:20 (d) 13:15

- Q61. The sum of ages of 4 children born at the interval of 2 years is 52. What is the age of the oldest child?
 (a) 10 years (b) 12 years (c) 14 years (d) 16 years
- Q62. A certain sum under compound interest, compounded annually, amounts to Rs. 5500/- in 5 years and Rs. 6050/- in 6 years. What is the rate of interest?
 (a) $12\frac{1}{2}\%$ (b) 15% (c) 20% (d) 10%
- Q63. Rs. 800 becomes Rs. 956 in 3 years at a certain rate of simple interest. If the rate of interest is increased by 4%, what amount will Rs. 800 becomes in 3 years?
 (a) Rs 1020.80 (b) Rs 1025 (c) Rs 1052 (d) Rs 1000
- Q64. A sum of money lent out at simple interest amounts to Rs 720 after 2 years and to Rs 1020 after a further period of 5 years. The sum is
 (a) Rs 500 (b) Rs 600 (c) Rs 700 (d) Rs 750
- Q65. Present age of X and Y are in the ratio 7:5 respectively. Four years hence, the ratio of their ages will become 11:9 respectively. What is the present age of Y?
 (a) 1 year (b) 7 year (c) 5 year (d) None of these

Q 66-70. Each of these questions given below contains three elements. These elements may or may not have some inter-linkage. Each group of elements may fit into one of these diagrams at (a), (b), (c) or (d). You have to indicate the group of elements which correctly fits into the diagrams.

- Q66. Which of the following diagrams indicates the best relation between Biology, Zoology and Physics?

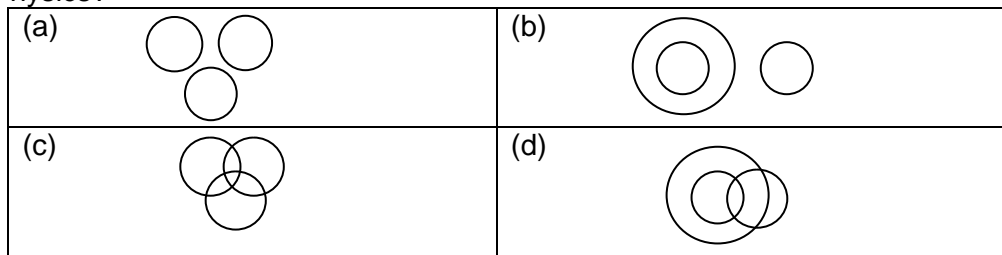

- Q67. Which of the following diagrams indicates the best relation between Stamp, Pen and Chalk?

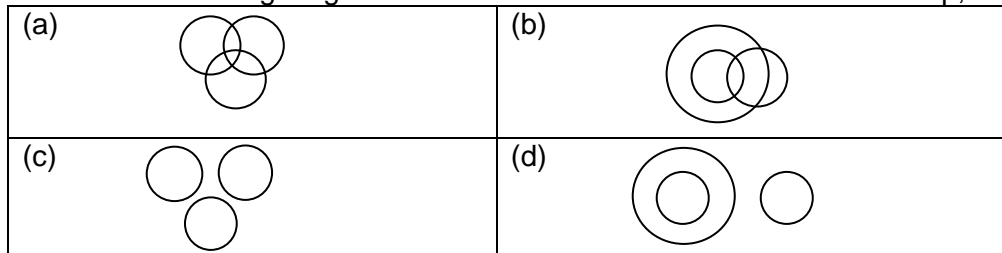

- Q68. Which of the following diagrams indicates the best relation between Singers, Athletes and Girls?

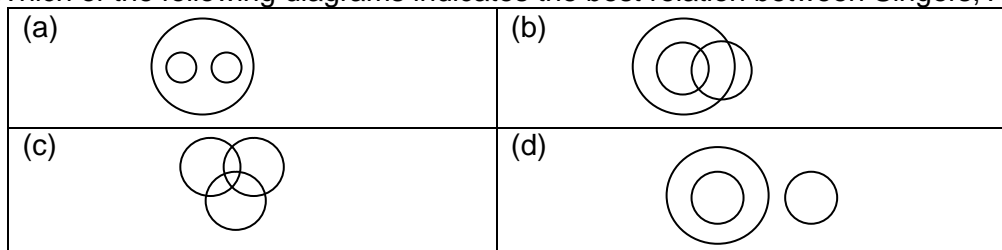

- Q69. Which of the following diagrams indicates the best relation between Teachers, Women and Doctors?

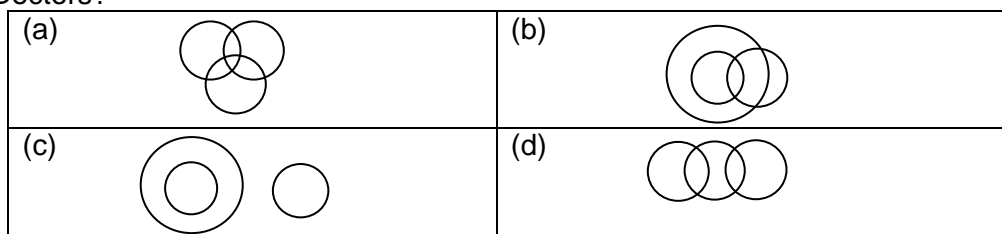

Q70. Which of the following diagrams indicates the best relation between Clothes, Flowers and White?



Q71-75 In each of the following questions find out the alternative which will replace the question mark.

Q71. Cerebrum : Brain :: ? : ?

- | | |
|-----------------------|------------------------|
| (a) Aorta : Hand | (b) Ligament : Blood |
| (c) Ventricle : Heart | (d) Country : Universe |

Q72. Monument : Cenotaph :: ? : ?

- | | |
|------------------------|----------------------|
| (a) Orifice : Opening | (b) Guide : Follower |
| (c) Protect : Protocol | (d) Sponsor : Cleave |

Q73. Meadow : Sheep :: ? : ?

- | | |
|-------------------------|----------------------|
| (a) Stable : Horse | (b) Hay : Insect |
| (c) Grass : Grasshopper | (d) Pasture : Cattle |

Q74. Sadist : Injury :: ? : ?

- | | |
|------------------------------|---------------------|
| (a) Opportunist : Generosity | (b) Priest : Church |
| (c) Dentist : Teeth | (d) Thief : Robbery |

Q75. Lecherous : Carnal :: ? : ?

- | | |
|---------------------|----------------------|
| (a) Virile : Feeble | (b) Diatribe : Abuse |
| (c) Impede : Begin | (d) Sunder : Link |

Q76-80 In each of the following questions, four words have been given out of which three are alike in some manner, while the fourth one is different. Choose the word which is different from the rest.

Q76. (a) Niger (b) Suez (c) Mississippi (d) Colorado

Q77. (a) Bang (b) Hiss (c) Whistle (d) Wink

Q78. (a) Gold (b) Silver (c) Bronze (d) Iron

Q79. (a) Mendicant (b) Ascetic (c) Pious (d) Hermit

Q80. (a) Bardoli (b) Bhadravati (c) Porbandar (d) Champaran

Q81-85. In each of the following questions, select a figure from amongst the four alternatives, which when placed in the blank space of figure (X) would complete the pattern.

Q81.

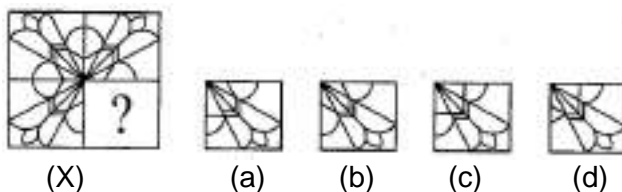

Q82.

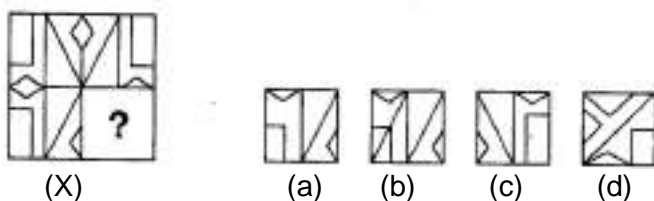

Q83.

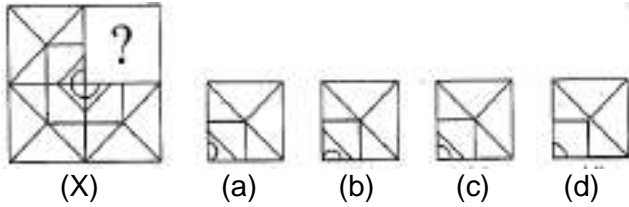

Q84.

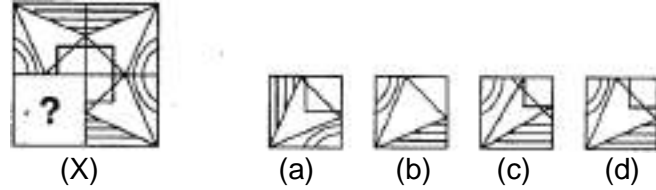

Q85.

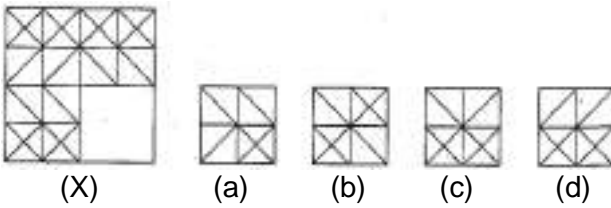

Q86-90. Each of the following questions consists of five figures marked 1,2,3,4 and 5 called the Problem Figures followed by four other figures marked a, b, c and d called the Answer Figures. Select a figure from amongst the Answer Figures which will continue the same series as established by the five Problem Figures.

Q86.



Q87.

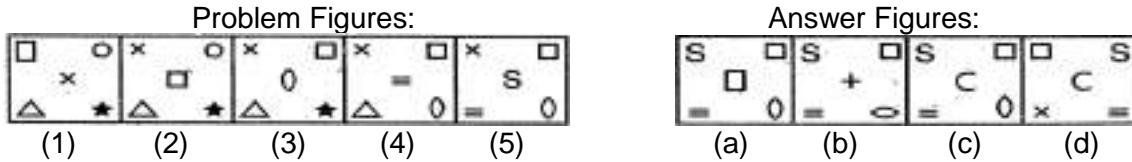

Q88.

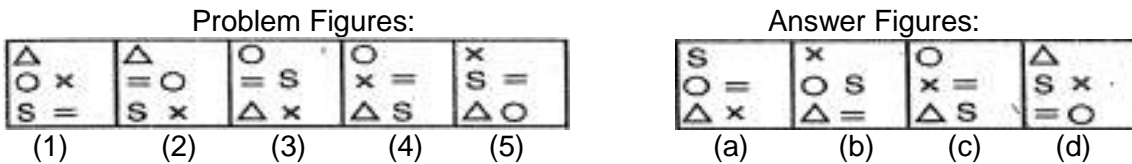

Q89.

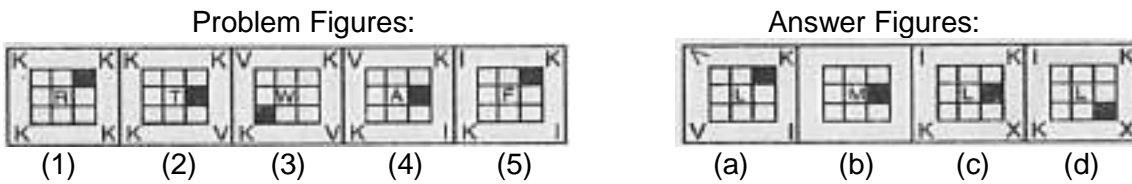

Q90.

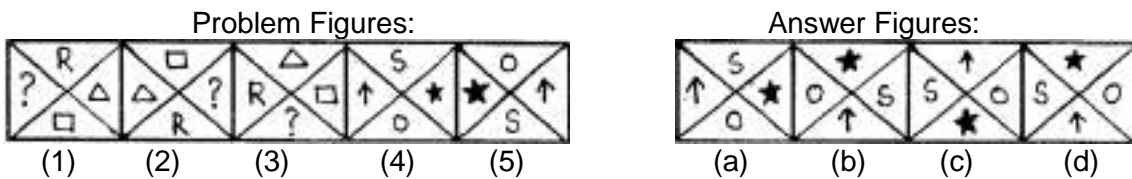

Q91-95. Each of the following questions consists of two sets of figures. Figures 1, 2, 3 and 4 constitute the Problem Set while figures a, b, c and d constitute the Answer Set. There is a definite relationship between figures (1) and (2). Establish a similar relationship between figures (3) and (4) by selecting a suitable figure from the Answer set that would replace the question mark (?) in fig (4).

Q91.

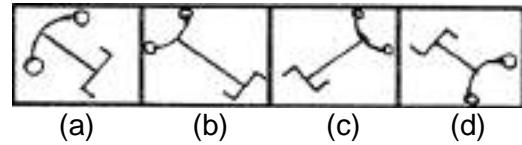
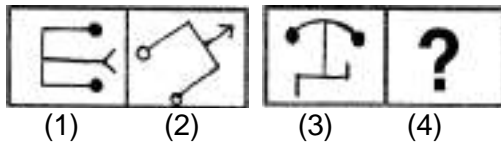

Q92.

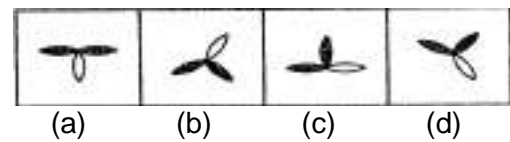
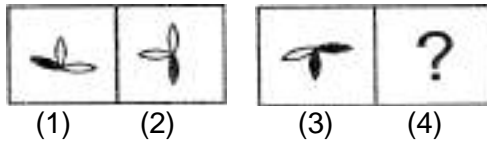

Q93.

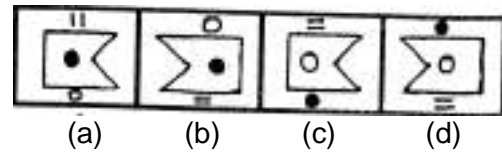
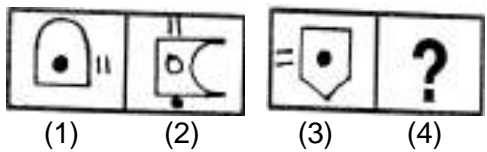

Q94.

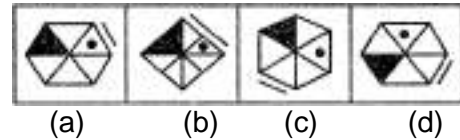
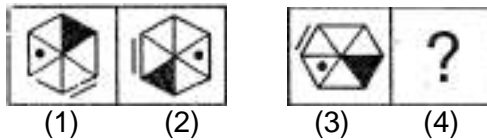

Q95.

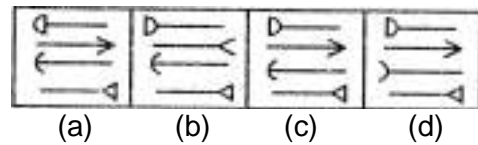
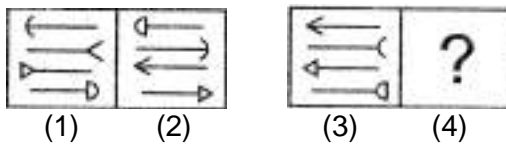

Q96-100. In each problem, out of the four figures marked (a) (b) (c) and (d) three are similar in a certain manner. However, one figure is not like the other three. Choose the figure which is different from the rest.

Q96.

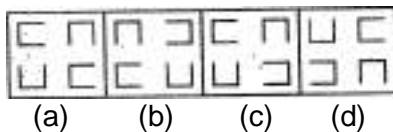

Q97.

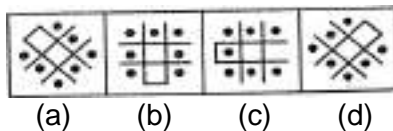

Q98.

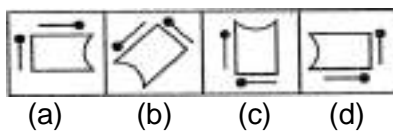

Q99.

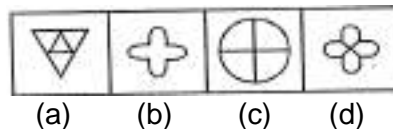

Q100.

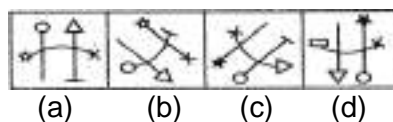

AFCAT Model Question Paper-IV

TIME ALLOTTED – 2HRS

INSTRUCTIONS FOR CANDIDATES

1. Total No Of Questions-100. Each Question is of three marks.
2. One mark will be deducted for every wrong answer.
3. No mark will be deducted for un-attempted questions.
4. Do not write on the Question Paper or make any mark on it.

Q1-4. Choose the word which is nearest in meaning to the given word:-

- Q1. Sagacious
(a) Stupid (b) Truthful (c) Lustful (d) Discerning
- Q2. Pontificate
(a) To speak authoritatively (b) To raise to higher office
(c) To act clumsily (d) To constitute
- Q3. Embellish
(a) Employ (b) Arrange
(c) Decorate (d) Design
- Q4. Damp Squib
(a) Insignificant happening (b) An old technique
(c) Unsuccessful attempt (d) Short, shrill cry

Q5-8. Choose the word that best defines the given phrases:-

- Q5. All agog
(a) Work helplessly (b) Lose consciousness
(c) In a state of excitement (d) Fall flat
- Q6. Espirit de Corps
(a) Bravery (b) Loyalty (c) Subordination (d) Unity
- Q7. Cloak and dagger
(a) To fight to a finish (b) To get into unexpected trouble
(c) To end the hostility (d) Like a spy
- Q8. To be at the end of one's tether
(a) To feel offended (b) To draw moral attention
(c) To have no resources left (d) To think deeply

Q9-12. Choose the correctly spelt word:-

- Q9. (a) Hindrance (b) Hinderance (c) Hindrence (d) Hinderence
- Q10. (a) Perjery (b) Perjury (c) Purjury (d) Perjary
- Q11. (a) Reminiscene (b) Reminiscence (c) Reminicence (d) Remeniscence
- Q12. (a) Omminous (b) Omineous (c) Ominous (d) Omenous

Q13-16. Choose the word which is nearly opposite in meaning to the given word:-

- Q13. Sporadic
(a) Rare (b) Frequent (c) Sharp (d) Coordinated
- Q14. Exonerate
(a) Reject (b) Contract (c) Accuse (d) Admit
- Q15. Parsimonious
(a) Generous (b) Selfish (c) Religious (d) Hereditary
- Q16. Vindicate
(a) Censure (b) Favour (c) Indicate (d) Eradicate

Q17-19. Read the following passage carefully and answer the questions given below it:-

Recently, a newspaper article mourned the total disappearance of the common house sparrow. This was a comment on the city's perceptible move towards edging out the flora and fauna of the city. In the rapid urbanization, multi-storied apartments grew and large scale felling of trees became necessary. Last week, however, seven pairs of these sparrows were spotted in a suburb. Possibly the greenery of this place has created a new habitat for these birds which like their proximity to human beings, and have made a comeback. A systematic development of trees and shrubs all over the city could woo the absentee house sparrow to our midst.

- Q17. According to the passage, the birds have made a comeback to the suburb because they
- have been hunted down by the village people
 - Love to be amidst human beings
 - get food only where human beings live
 - they have been deliberately brought back by biologists
- Q18. In the passage the term "urbanisation" has been used to refer to
- the destruction of the greenery in the city
 - construction of concrete structures on a large scale
 - a change over from the rural life to the city life
 - the movement of people from villages to cities
- Q19. The phrase "absentee house sparrow" refers to
- the sparrow that makes infrequent visits
 - the sparrow that has forgotten its habitat
 - the sparrow that has gone away from the urban areas
 - the sparrow that has become extinct

Q20-25 Select the most appropriate word from the options against each number:-

Watermelons ..(20).. to India by the 4th century A.D. Sushruta, the great Indian physician,(21)...wrote Sushruta Samhit, mentions that watermelons were grown ..(22).. the banks of the river Indus.(23)....are also mentioned in ancient books. Sushruta calls it as Kalinda or Kalinga (hence Kalingad in Marathi). It was...(24)..to China in the 10th or 11th century and ...(25)... it is grown throughout the tropics.

- Q20. (a) came (b) go (c) arrived (d) started
- Q21. (a) did (b) when (c) certainly (d) who
- Q22. (a) above (b) outside (c) from (d) along
- Q23. (a) it (b) they (c) some (d) that
- Q24. (a) took (b) gave (c) taken (d) take
- Q25. (a) also (b) though (c) now (d) tomorrow

Q26-29. Which word or words explains the meaning of the following idioms:-

- Q26. Lay bare
- Expose
 - Take off all clothes
 - Destroy
 - Exploit
- Q27. A wolf in sheep's clothing
- A hypocrite
 - A wolf in woolen clothes
 - A coward
 - A proud man
- Q28. A blue stocking
- Stocking which is blue in colour
 - A clean cheat
 - An unreliable person
 - a woman having literary tastes and learning
- Q29. Yeoman's service
- lip-service
 - to serve like a slave
 - to play god father
 - efficient or useful help

Q30-65. Choose the most appropriate answer:-

- Q30. Which country will host the XXXI Olympic Games in 2016?
 (a) Rio de Janeiro, Brazil (b) Chicago, USA
 (c) Tokyo, Japan (d) Doha, Qatar
- Q31. The book, 'A China Passage' was written by
 (a) MJ Akbar (b) Jagmohan
 (c) Anees Jung (d) John Kenneth Galbraith
- Q32. Who was the founder of Nanda dynasty?
 (a) Bimbisara (b) Mahapadma Nanda
 (c) Ajatasatru (d) Dhana Nanda
- Q33. Which of the following books is written by Arnold Toynbee?
 (a) Mankind and Mother Earth (b) Tom Sawyer
 (c) The Future of Freedom (d) The Moon's Last Sigh
- Q34. The national emblem, viz four lions standing back to back is an adaptation from which of the following:-
 (a) Sarnath lions (b) Gir lions
 (c) Khajurao (d) Ajanta caves
- Q35. Who was the person behind conversion of East India Company from a trading company into a regional power?
 (a) Lord Warren Hastings (b) Lord Clive
 (c) Lord Dalhousie (d) Lord Wellesley
- Q36. Who inscribed the name of Khalifa of Baghdad on his coins?
 (a) Ala-ud-din Khilji (b) Iltutmish
 (c) Qutub-ud-din Aibak (d) Balban
- Q37. Who among the following is not a recipient of the 'Bharatiya Jnanpith' Award?
 (a) Ashapurna Devi (b) MF Hussain
 (c) Raghupati Sahay (d) VK Gokak
- Q38. Global 500 awards are given for outstanding achievement in which of the following fields?
 (a) Population Control (b) Elimination of illiteracy
 (c) Campaigning against AIDS (d) Protection of environment
- Q39. Who among the following Sultans of Delhi assumed the title, 'Sikandar-i-Sani'?
 (a) Balban (b) Ala-ud-din Khilji
 (c) Muhammad-bin-Tughlaq (d) Sikander Lodhi
- Q40. UN General Assembly recently declared 21st June as
 (a) International Youth Day (b) International Literacy Day
 (c) International Day of Yoga (d) International Day of Peace
- Q41. Pulitzer Prize is awarded for outstanding work in the field of
 (a) Science and Technology (b) Environmental Studies
 (c) Literature and Journalism (d) International Understanding
- Q42. The presidency of the UN Security Council rotates among the Council Members
 (a) Every 6 months (b) Every year
 (c) Every 3 months (d) Every month
- Q43. The member countries of NAFTA are
 (a) USA, Canada and Mexico (b) Canada and Mexico
 (c) USA and Canada (d) Argentina and Brazil
- Q44. Who were the contemporaries of the Gupta Kings in the south?
 (a) Chola (b) Rashtrakutas
 (c) Satavahanas (d) Vakatakas
- Q45. Sandeep Sejwal won the Bronze medal in 2014 Asian Games in which of the following events?
 (a) 200m backstroke (b) 200m freestyle
 (c) 50m breaststroke (d) 50m butterfly

- Q46. Mangalyan, Mars Orbiter Mission (MOM) was launched in
 (a) Jan 2013 (b) Oct 2012 (c) Oct 2013 (d) Nov 2013
- Q47. "Ruhr of India" known for its rich coal deposits is in the State of
 (a) Uttar Pradesh (b) Jharkhand (c) West Bengal (d) Bihar
- Q48. The Indian space programme began in
 (a) 1961 (b) 1962 (c) 1965 (d) 1969
- Q49. 'Bachpan Bachao Andolan (BBA)', an organisation to protect the rights of children was founded by
 (a) Amir Khan (b) Kailash Satyarthi
 (c) Om Prakash Gurjar (d) Santa Sinha
- Q50. Which of the following Subsonic missiles, test fired in October 2014 is considered India's answer to America's Tomahawk missile?
 (a) Brahmos Mk-2 (b) Prahaar (c) Nirbhay (d) Agni-V
- Q51. Who among the following won the World Billiards Championship held in England in October 2014?
 (a) Peter Gilchrist (b) Pankaj Advani
 (c) Saurav Kothari (d) None of these
- Q52. The sum of ages of 4 children born at the interval of 2 years is 52. What is the age of the oldest child?
 (a) 10 years (b) 12 years (c) 14 years (d) 16 years
- Q53. A certain sum under compound interest, compounded annually, amounts to Rs. 5500/- in 5 years and Rs. 6050/- in 6 years. What is the rate of interest?
 (a) $12\frac{1}{2}\%$ (b) 15% (c) 20% (d) 10%
- Q54. Rs. 800 becomes Rs. 956 in 3 years at a certain rate of simple interest. If the rate of interest is increased by 4%, what amount will Rs. 800 becomes in 3 years?
 (a) Rs 1020.80 (b) Rs 1025 (c) Rs 1052 (d) Rs 1000
- Q55. A sum of money lent out at simple interest amounts to Rs 720 after 2 years and to Rs 1020 after a further period of 5 years. The sum is
 (a) Rs 500 (b) Rs 600 (c) Rs 700 (d) Rs 750
- Q56. Present age of X and Y are in the ratio 7:5 respectively. Four years hence, the ratio of their ages will become 11:9 respectively. What is the present age of Y?
 (a) 1 year (b) 7 year (c) 5 year (d) None of these
- Q57. A can do a piece of work in 20 days and B in 25 days. They work together for 5 days and then B goes away. In how many days will A finish the work?
 (a) 11 days (b) 9 days (c) 20 days (d) 21 days
- Q58. Two train A & B each 66 meters long run parallel to each other in the same direction. Their speeds are 50 Kmph and 30 Kmph respectively. In what time A will completely pass B.
 (a) 28 Sec (b) 28.46 Sec (c) 53.46 Sec (d) 23.76 Sec
- Q59. A train 77.5 m in length is running at the rate of 65 Kmph. Find the time taken by the train to pass the man walking in the same direction as the train @ 3 Kmph.
 (a) 2.5 Sec (b) 4.5 Sec (c) 6.5 Sec (d) 8 Sec
- Q60. Ram can row $7\frac{1}{2}$ Kmph in still water. If in a river running at 1.5 Km an hour, it takes him 50 minutes to row to a place and back, how far is the place?
 (a) 3.5 Km (b) 3 Km (c) 4.5 Km (d) 5 Km
- Q61. A motorboat with speed 15 Kmph in still water goes 30 Km downstream and comes back. It covers the distance in 4 hours and 30 minutes. The speed of the stream in Km/h is?
 (a) 4 (b) 5 (c) 6 (d) 10
- Q62. Zinc and copper are melted together in the ratio 9:11. What is the weight of the melted mixture, if 28.8 kg of zinc has been consumed in it?
 (a) 58 Kg (b) 60 Kg (c) 64 Kg (d) 70 Kg

- Q63. A sells his goods 20% cheaper than B and 20% dearer than C. How much percentage is C's goods cheaper / dearer than B.
 (a) 33.33% (b) 50% (c) 45.85% (d) None of these
- Q64. The average of 6 observations is 12. If the 7th observation is included, the average is reduced by 1. What will be the 7th observation?
 (a) 4 (b) 5 (c) 6 (d) 7
- Q65. If the incomes of Ram & Shyam are in the ratio of 3:4 and their expenditures in the ratio of 4:5, find the ratio of their savings, given that Shyam saves a third of his income.
 (a) 10:15 (b) 13:20 (c) 15:20 (d) 13:15

Q66-70 In each of the following questions find out the alternative which will replace the question mark.

- Q66. Sadist : Injury :: ??
 (a) Opportunist : Generosity (b) Priest : Church
 (c) Dentist : Teeth (d) Thief : Robbery
- Q67. Lecherous : Carnal :: ??
 (a) Virile : Feeble (b) Diatribe : Abuse
 (c) Impede : Begin (d) Sunder : Link
- Q68. Cerebrum : Brain :: ??
 (a) Aorta : Hand (b) Ligament : Blood
 (c) Ventricle : Heart (d) Country : Universe
- Q69. Monument : Cenotaph :: ??
 (a) Orifice : Opening (b) Guide : Follower
 (c) Protect : Protocol (d) Sponsor : Cleave
- Q70. Meadow : Sheep :: ??
 (a) Stable : Horse (b) Hay : Insect
 (c) Grass : Grasshopper (d) Pasture : Cattle

Q71-75. In each of the following questions, select a figure from amongst the four alternatives, which when placed in the blank space of figure (X) would complete the pattern.

Q71.

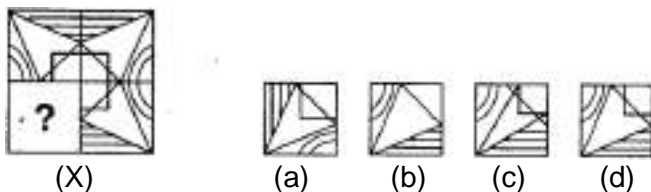

Q72.

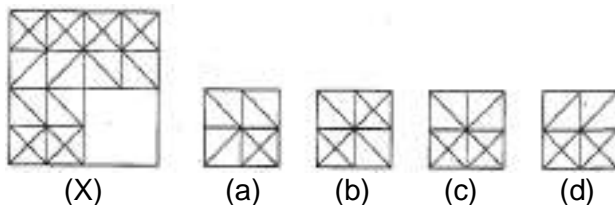

Q73.

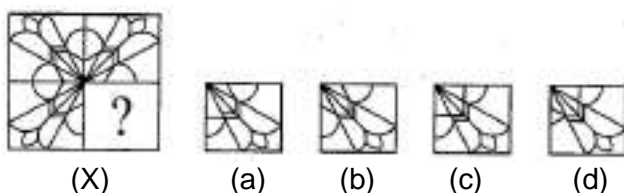

Q74.

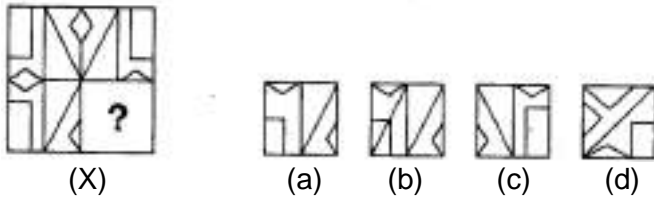

Q75.

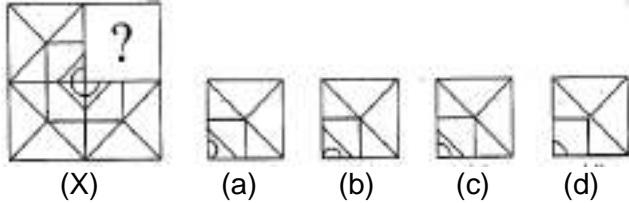

Q 76-80. Each of these questions given below contains three elements. These elements may or may not have some inter-linkage. Each group of elements may fit into one of these diagrams at (a), (b), (c) or (d). You have to indicate the group of elements which correctly fits into the diagrams.

Q76. Which of the following diagrams indicates the best relation between Biology, Zoology and Physics?

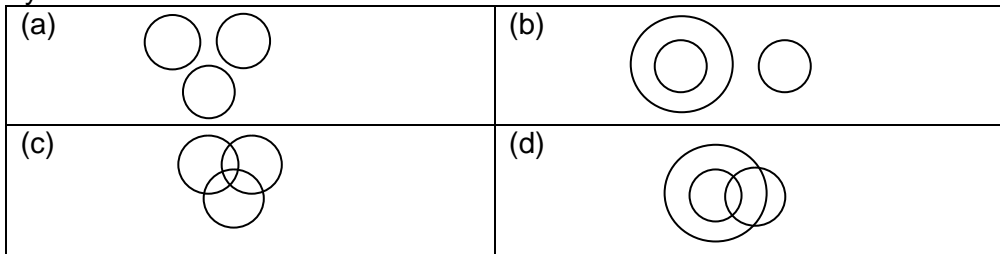

Q77. Which of the following diagrams indicates the best relation between Stamp, Pen and Chalk?

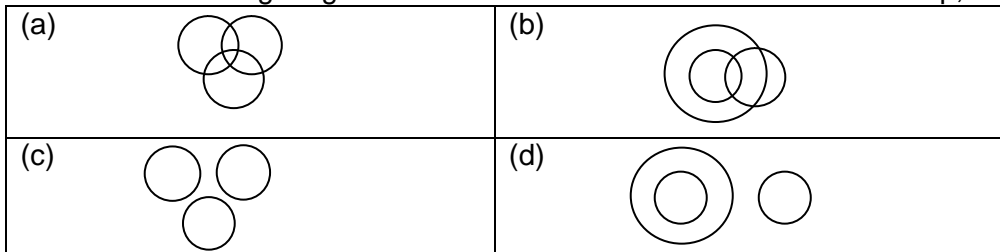

Q78. Which of the following diagrams indicates the best relation between Singers, Athletes and Girls?

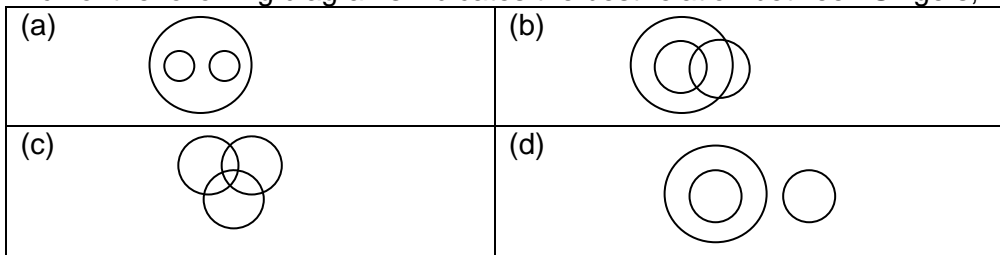

Q79. Which of the following diagrams indicates the best relation between Teachers, Women and Doctors?

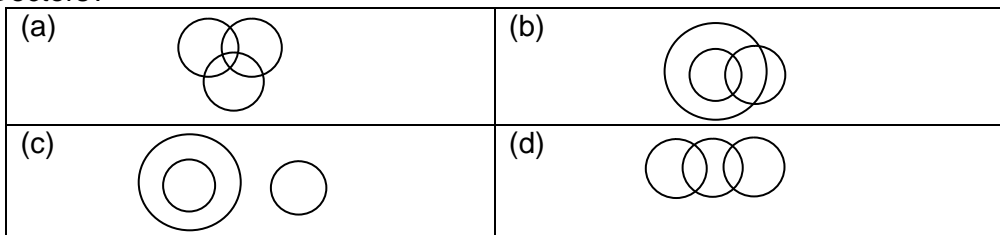

Q80. Which of the following diagrams indicates the best relation between Clothes, Flowers and White?

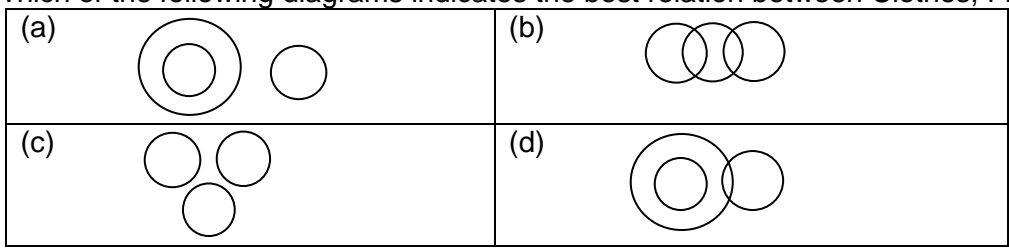

Q81-85. Each of the following questions consists of five figures marked 1,2,3,4 and 5 called the Problem Figures followed by four other figures marked a, b, c and d called the Answer Figures. Select a figure from amongst the Answer Figures which will continue the same series as established by the five Problem Figures.

Q81

Problem Figures:

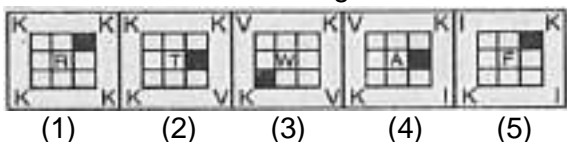

Answer Figures:

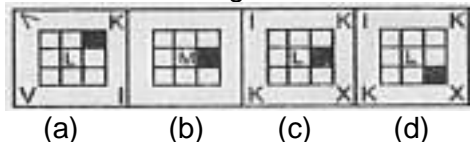

Q82.

Problem Figures:

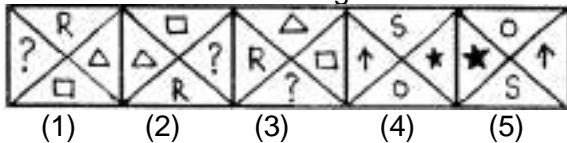

Answer Figures:

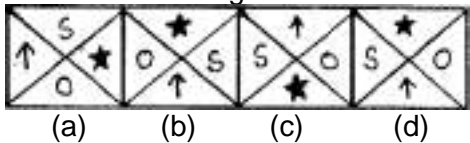

Q83.

Problem Figures:

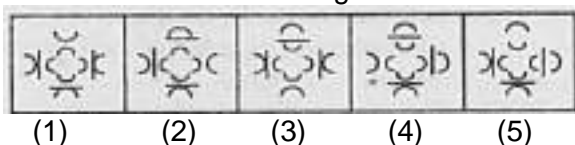

Answer Figures:

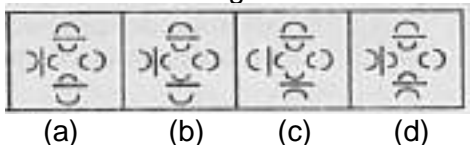

Q84.

Problem Figures:

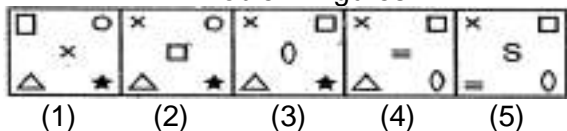

Answer Figures:

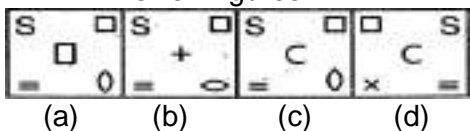

Q85.

Problem Figures:

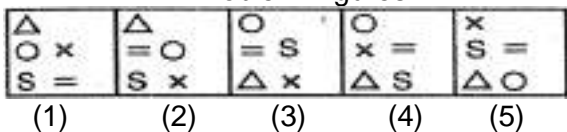

Answer Figures:

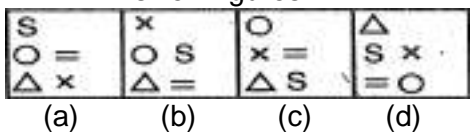

Q86-90. Each of the following questions consists of two sets of figures. Figures 1, 2, 3 and 4 constitute the Problem Set while figures a, b, c and d constitute the Answer Set. There is a definite relationship between figures (1) and (2). Establish a similar relationship between figures (3) and (4) by selecting a suitable figure from the Answer set that would replace the question mark (?) in fig (4).

Q86.



Q87.



Q88.

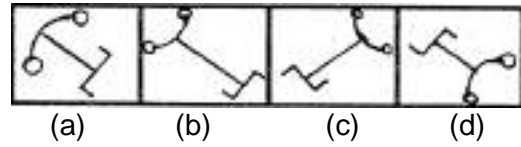
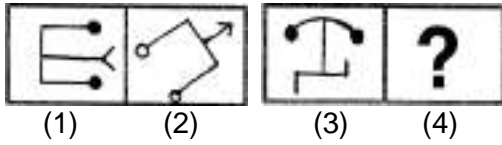

Q89.

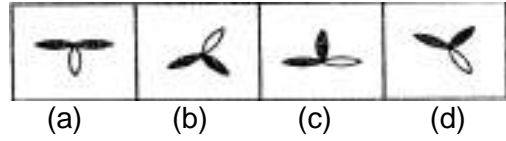
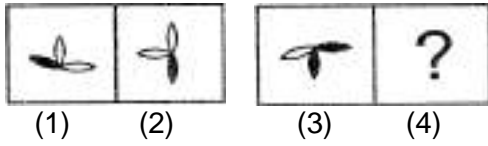

Q90.

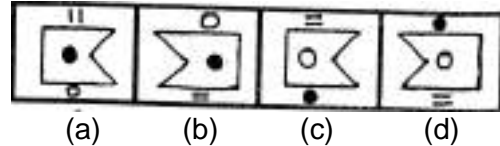
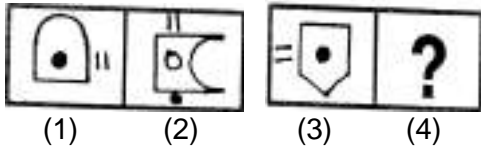

Q91-95. In each problem, out of the four figures marked (a) (b) (c) and (d) three are similar in a certain manner. However, one figure is not like the other three. Choose the figure which is different from the rest.

Q91.

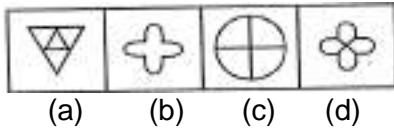

Q92.

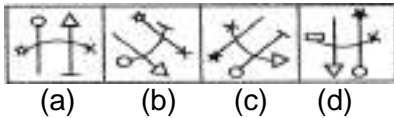

Q93.

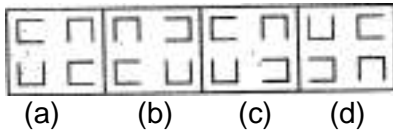

Q94.

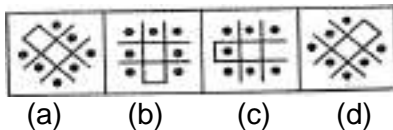

Q95.

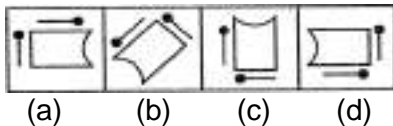

Q96-100 In each of the following questions, four words have been given out of which three are alike in some manner, while the fourth one is different. Choose the word which is different from the rest.

Q96. (a) Mendicant (b) Ascetic (c) Pious (d) Hermit

Q97. (a) Bardoli (b) Bhadravati (c) Porbandar (d) Champaran

Q98. (a) Niger (b) Suez (c) Mississippi (d) Colorado

Q99. (a) Bang (b) Hiss (c) Whistle (d) Wink

Q100. (a) Gold (b) Silver (c) Bronze (d) Iron

INSTRUCTIONS FOR CANDIDATES

1. Total Number of Questions-100. Each Question is of three marks.
2. One mark will be deducted for every wrong answer.
3. No mark will be deducted for un-attempted questions.
4. Do not write on the Question Paper or make any mark on it.

Q1-3. Read the following passage carefully and answer the questions given below it:-

In spring, polar bear mothers emerge from dens with three months old cubs. The mother bear has fasted for as long as eight months but that does not stop the young from demanding full access to her remaining reserves. If there are triplets, the most persistent stands to gain an extra meal at the expense of others. The smallest of the cubs forfeits many meals to stronger siblings. Females are protective of their cubs but tend to ignore family rivalry over food. In 21 years of photographing polar bears, I have only once seen the smallest of triplets survive till autumn.

- Q1. Female polar bears give birth during
 (a) Spring
 (b) Summer
 (c) Autumn
 (d) Winter
- Q2. Mother bear
 (a) Takes sides over cubs
 (b) Lets the cubs fend for themselves
 (c) Feeds only their favourites
 (d) Sees that all cubs get an equal share
- Q3. With reference to the passage, the following assumptions have been made:-
 I. Polar bears fast as long as eight months due to non availability of prey.
 II. Polar bears always give birth to triplets.
 Which of the assumptions given above is/ are true?
 (a) I only (b) II only (c) Both I and II (d) Neither I nor II

Q4-9 Select the most appropriate word from the options against each number:-

As home entertainment, television is rapidly becoming more (4) than any other form. A news broadcast becomes more immediate when people (5) actually see the scene (6) question and the movement of the figures. Films could be viewed in the (7) of the home and a variety of shows are also available. One of the advantages of travel programmes is the (8) of faraway places which many viewers would not (9) see.

- Q4. (a) interesting (b) popular (c) powerful (d) purposeful
 Q5. (a) could (b) would (c) might (d) shall
 Q6. (a) of (b) with (c) as (d) in
 Q7. (a) surroundings (b) assistance (c) comfort (d) privilege
 Q8. (a) glimpses (b) image (c) portrait (d) picture
 Q9. (a) possible (b) rather (c) else (d) otherwise

Q10-13. Choose the word which is nearest in meaning to the given word:-

- Q10. Intransigent
 (a) Authoritative (b) Impersonal (c) Strenuous (d) Unbending
- Q11. Intimidate
 (a) Mislead (b) Misplace (c) Frighten (d) Demoralise
- Q12. Sporadic
 (a) Epidemic (b) Whirling (c) Occasional (d) Stagnant
- Q13. Genesis
 (a) Style (b) Beginning (c) Movement (d) Relevant

Q14-17. Choose the word which is nearly opposite in meaning to the given word:-

- Q14. Malevolent
 (a) Kindly (b) Vacuous (c) Ambivalent (d) Primitive
- Q15. Purgatory
 (a) Reward (b) Celestial (c) Flawless (d) Proximity
- Q16. Clemency
 (a) Corporal (b) Intolerance (c) Compromise (d) Sensibility
- Q17. Cajole
 (a) Nestle (b) Secede (c) Bully (d) Moisten

Q18-21. Choose the word that best defines the given phrases:-

- Q18. In weal and woe
 (a) By hook or crook (b) During illness
 (c) in prosperity and adversity (d) During the operation
- Q19. Globetrotters
 (a) People against global philosophy (b) People indulging in treachery
 (c) Intelligent minds (d) Travellers around the world
- Q20. A Curtain Lecture
 (a) To speak plainly (b) Vulgar Ideas
 (c) Private scolding of a husband by his wife (d) Hate others
- Q21. Square pegs in round holes
 (a) A genuinely helpful person (b) A Clever person
 (c) People in the wrong jobs (d) To be perplexed

Q22-25. Choose the correctly spelt word:-

- Q22. (a) Equanimity (b) Equannimity (c) Equanimmisty (d) Equinimity
- Q23. (a) Vetarinary (b) Veteninary (c) Veterinary (d) Vetniary
- Q24. (a) Konnoisseur (b) Conoisisseur (c) Connoisseur (d) Konoisseur
- Q25. (a) Munifisent (b) Muneficent (c) Munificent (d) Munificent

Q26-29. Which word or words explains the meaning of the following idioms:-

- Q26. In a jiffy
 (a) Outstanding (b) Suddenly (c) In a fix (d) Appropriate
- Q27. Upto the hilt
 (a) Completely (b) Upto the mark
 (c) Upto the final decision (d) None of these
- Q28. Man of Letters
 (a) Who writes too many letters (b) An important person
 (c) A politician (d) A literary person
- Q29. Sangfroid
 (a) Composure (b) Go on leave
 (c) Changed Suddenly (d) Make an attempt

Q30-65. Choose the most appropriate answer:-

- Q30. Which country among the following has been declared Ebola-free by WHO?
 (a) Sierra Leone (b) Liberia (c) Nigeria (d) Guinea
- Q31. How many Gold medals did India win in the Incheon Asian Games held in Oct 2014?
 (a) 10 (b) 11 (c) 12 (d) 8
- Q32. Who has been appointed as the new Finance Secretary of India?
 (a) Arvind Mayaram (b) Rajiv Mehrishi
 (c) Kaushik Basu (d) Dinesh Gupta

- Q33. Which among the following is India's first long range subsonic cruise missile?
 (a) Agni II (b) Prithvi (c) Dhanush (d) Nirbhay
- Q34. The branch of science that studies cells is called
 (a) Cytology (b) Entomology (c) Homoplastic (d) Hormonology
- Q35. How many Vice Presidents are elected at the start of its each regular session of UN General Assembly?
 (a) Nine (b) Fifteen (c) Two (d) Twenty one
- Q36. The highest civilian award of India 'Bharat Ratna' has been awarded to only two foreigners so far. One of them is Nelson Mandela. The other is
 (a) Marshal Tito (b) Mikhail Gorbachev
 (c) Khan Abdul Ghaffar Khan (d) Abdul Wali Khan
- Q37. Sir CV Raman was awarded Nobel Prize for his work connected with which of the following phenomenon of radiation?
 (a) Scattering (b) Diffraction (c) Interference (d) Polarisation
- Q38. In which city is the headquarters of Asian Development Bank located?
 (a) Manila (b) Singapore (c) Bangkok (d) Jakarta
- Q39. K-15 missile is
 (a) Submarine launched Ballistic Missile (SLBM)
 (b) Inter Continental Ballistic Missile (ICBM)
 (c) Medium Range Ballistic Missile (MRBM)
 (d) Short Range Ballistic Missile (SRBM)
- Q40. India agreed to UN Chief Ban Ki-Moon's offer to remain as a member of the advisory board of one of the following recently.
 (a) UNCCT (b) UNICEF (c) UNEP (d) UNCTAD
- Q41. Kaziranga National Park is famous for
 (a) One-horned Rhinos (b) Tigers
 (c) Swamp Dears (Barasingha) (d) Elephants
- Q42. Who was the first Indian to win an individual medal in Olympics?
 (a) Milkha Singh (b) PT Usha
 (c) Karnam Malleshwari (d) KD Jadhav
- Q43. Who among the following was the Congress President at Madras Session of 1927 when it boycotted the Simon Commission?
 (a) Maulana Abul Kalam Azad (b) MA Ansari
 (c) Lala Lajpat Rai (d) Subhash Chandra Bose
- Q44. Why did Kalinga prove to be a turning point in the life of Ashoka?
 (a) Ashoka annexed Kalinga
 (b) It was the starting point of the expansion of his empire
 (c) Ashoka became a zealous Buddhist
 (d) It enabled Mauryan Empire to reach its climax
- Q45. Which of the following wings was not part of the espionage system described by Kautilya?
 (a) Crime Branch (b) Special Branch
 (c) Political Branch (d) None of these
- Q46. Alauddin Khalji did not build
 (a) Siri Fort (b) Tomb of Jalaluddin
 (c) Hauz-i-Alai (d) Jamaat Khana Masjid
- Q47. Which of the following dynasties was ruling over North India at the time of Alexander's invasion?
 (a) Nanda (b) Maurya (c) Sunga (d) Kanva
- Q48. Which of the following Intercontinental Ballistic Missiles (ICBMs) is under development in India?
 (a) Agni-I (b) Agni-II (c) Agni-IV (d) Agni-VI

- Q49. Who among the following was adjudged as the Most Valuable Player of the 17th Asian Games held at Incheon, South Korea?
 (a) Mary Kom of India (b) Kosuke Hagino of Japan
 (c) Ning Zetao of China (d) None of these
- Q50. The opposition party status is accorded to a political party in the Lok Sabha only if it captures at least
 (a) 5% Seats (b) 10% Seats (c) 15% Seats (d) 20% Seats
- Q51. Who amongst the following is the author of the book 'A Bend in the River'?
 (a) Chetan Bhagat (b) VS Naipaul
 (c) Kiran Desai (d) Anita Desai
- Q52. 'Long Walk to Freedom' is a book written by
 (a) Sonia Gandhi (b) LK Advani
 (c) Nelson Mandela (d) Benazir Bhutto
- Q53. Which sports personality has been awarded the honorary rank of Group Captain by the IAF?
 (a) Kapil Dev (b) Sania Mirza
 (c) Saina Nehwal (d) Sachin Tendulkar
- Q54. A man travelled from a point A to B at the rate of 25 Kmph and walked back at the rate of 4 Kmph. If the whole journey took 5 hrs 48 minutes, the distance between A and B is
 (a) 30 Km (b) 24 Km (c) 20 Km (d) 51.6 Km
- Q55. A Train travelling at a uniform speed clears a platform 200 m long in 10 seconds and passes a telegraph post in 5 seconds. The speed of the train is
 (a) 36 km/h (b) 39 km/h (c) 72 km/h (d) 78 km/h
- Q56. The price of sugar increases by 20% due to the festive season. By what percentage should a family reduce the consumption of sugar so that there is no change in the expenditure?
 (a) 20% (b) $18\frac{1}{3}\%$ (c) $16\frac{2}{3}\%$ (d) $16\frac{1}{3}\%$
- Q57. A's salary is 20% lower than B's salary, which is 15% lower than C's salary. By how much percent is C's salary more than A's salary?
 (a) 44.05% (b) 45.05% (c) 46.05% (d) 47.05%
- Q58. The average weight of 5 men is increased by 2 Kg when one of the men whose weight is 60 Kg is replaced by a new man. The weight of the new man is
 (a) 50 Kg (b) 65 Kg (c) 68 Kg (d) 70 Kg
- Q59. A and B can do a piece of work in 18 days; B and C can do it in 24 days, A and C can do it in 36 days. In how many days B alone can finish the work?
 (a) 48 days (b) 45 days (c) $28\frac{4}{5}$ days (d) 144 days
- Q60. A, B and C can do a piece of work in 20, 30 and 60 days respectively. In how many days can A do the work if he is assisted by B and C on every third day?
 (a) 12 days (b) 15 days (c) 16 days (d) 18 days
- Q61. A man can row $9\frac{1}{3}$ Kmph in still water and finds that it takes him thrice as much time to row up than as to row down the same distance in the river. The speed of the current is
 (a) $3\frac{1}{3}$ Kmph (b) $3\frac{1}{9}$ Kmph (c) $4\frac{2}{3}$ Kmph (d) $4\frac{1}{3}$ Kmph
- Q62. The speed of a boat in still water is 10 Kmph. If it can travel 26 Km downstream and 14 Km upstream in the same time, the speed of the stream is
 (a) 2 Kmph (b) 2.5 Kmph (c) 3 Kmph (d) 4 Kmph
- Q63. If a sum becomes double in 16 years, how many times will it be in 8 years?
 (a) $1\frac{1}{2}$ times (b) $1\frac{1}{3}$ times (c) $1\frac{3}{4}$ times (d) $1\frac{1}{4}$ times

Q64. In how many years will a sum of Rs 800 at 10% per annum compounded semi-annually become Rs 926.10?

- (a) $1\frac{1}{3}$ (b) $1\frac{1}{2}$ (c) $2\frac{1}{3}$ (d) $2\frac{1}{2}$

Q65. A sells 2 TV sets, one at a loss of 15% and another at a profit of 15%. Find the loss/gain percentage in the overall transaction?

- (a) 2.25% (b) 3% (c) 4% (d) No profit, no loss

Q 66-70. Each of these questions given below contains three elements. These elements may or may not have some inter-linkage. Each group of elements may fit into one of these diagrams at (a), (b), (c) or (d). You have to indicate the group of elements which correctly fits into the diagrams.

Q66. Which of the following diagrams indicates the best relation between Doctors, Human Beings and Married People?

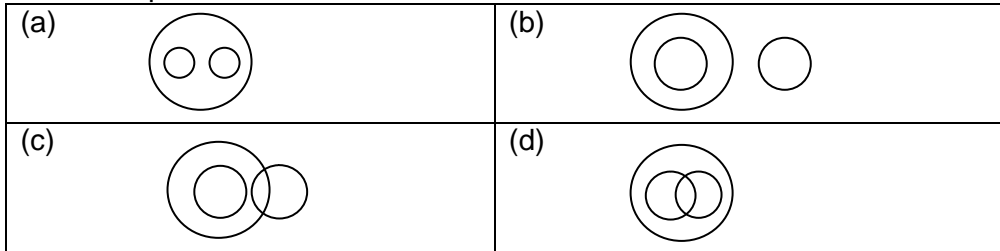

Q67. Which of the following diagrams indicates the best relation between Man, Worker and Garden?

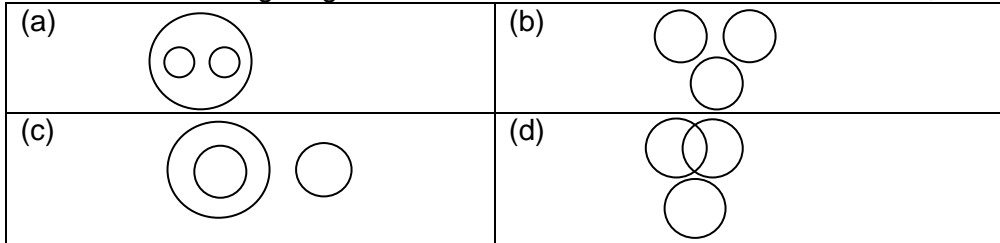

Q68. Which of the following diagrams indicates the best relation between Males, Cousins and Nephews?

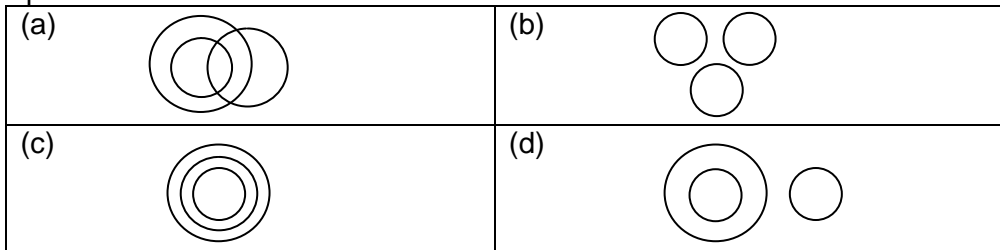

Q69. Which of the following diagrams indicates the best relation between Children, Naughty, and Studious?

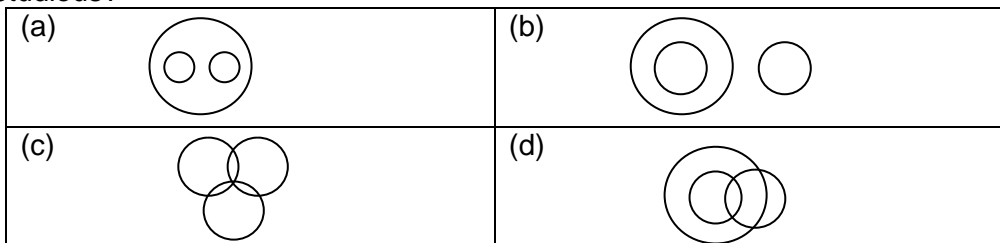

Q70. Which of the following diagrams indicates the best relation between Thief, Criminal and Police?

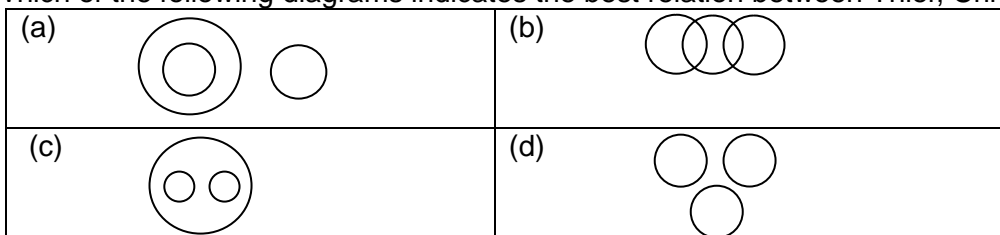

Q71-75 In each of the following questions find out the alternative which will replace the question mark.

Q71. Loath : Coercion :: ? : ?

- (a) Detest : Caressing (b) Irritate : Caressing
(c) Irate : Antagonism (d) Reluctant : Persuasion

Q72. Trilogy : Novel :: ? : ?

- (a) Rice : Husk (b) Milk : Cream
(c) Serial : Episode (d) Gun : Cartridge

Q73. Wife : Marriage :: ? : ?

- (a) Bank : Money (b) Nationality : Citizenship
(c) Service : Qualification (d) Attendance : Register

Q74. East : Orient :: ? : ?

- (a) North : Polar (b) North : Tropic
(c) South : Capricorn (d) West : Occident

Q75. Ignominy : Disloyalty :: ? : ?

- (a) Death : Victory (b) Martyr : Man
(c) Fame : Heroism (d) Destruction : Victory

Q76-80. In each of the following questions, four words have been given out of which three are alike in some manner, while the fourth one is different. Choose the word which is different from the rest.

Q76. (a) Aravalli hills (b) Shivalik hills (c) Mole hills (d) Satpura hills

Q77. (a) Beaver (b) Alpaca (c) Walrus (d) Koala

Q78. (a) Othello (b) King Lear (c) Oliver Twist (d) Macbeth

Q79. (a) Nimitz (b) Yamamoto (c) Nelson (d) Montgomery

Q80. (a) Blaze (b) Glint (c) Simmer (d) Shimmer

Q81-85. In each of the following questions, select a figure from amongst the four alternatives, which when placed in the blank space of figure (X) would complete the pattern.

Q81.

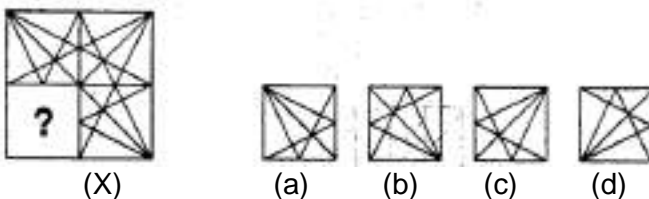

Q82.

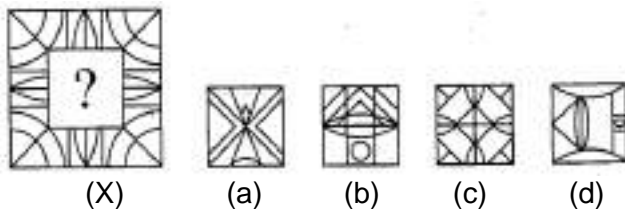

Q83.

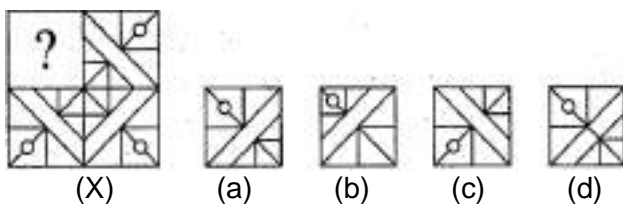

Q84.

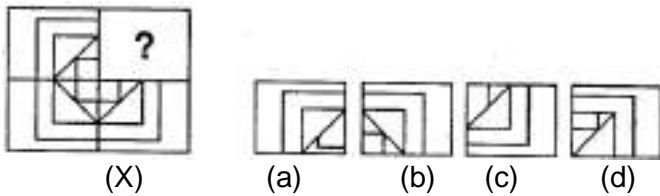

Q85.

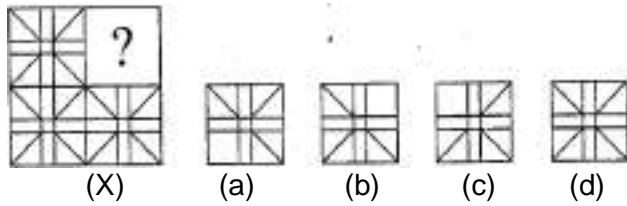

Q86-90. Each of the following questions consists of five figures marked 1,2,3,4 and 5 called the Problem Figures followed by four other figures marked a, b, c and d called the Answer Figures. Select a figure from amongst the Answer Figures which will continue the same series as established by the five Problem Figures.

Q86.



Q87.

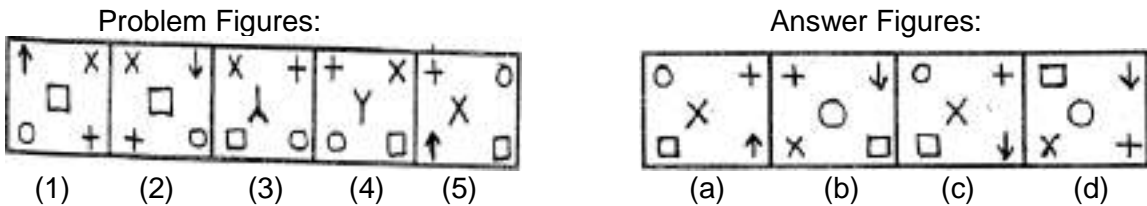

Q88.

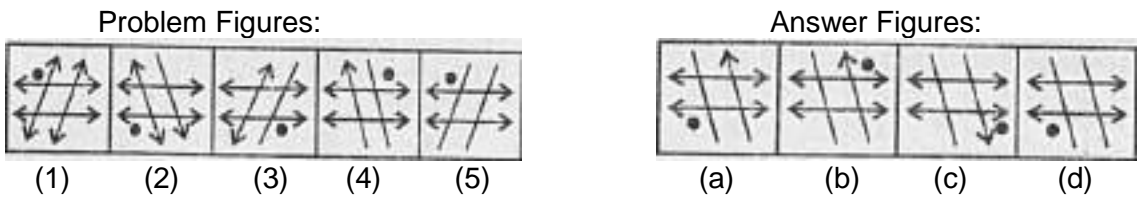

Q89.

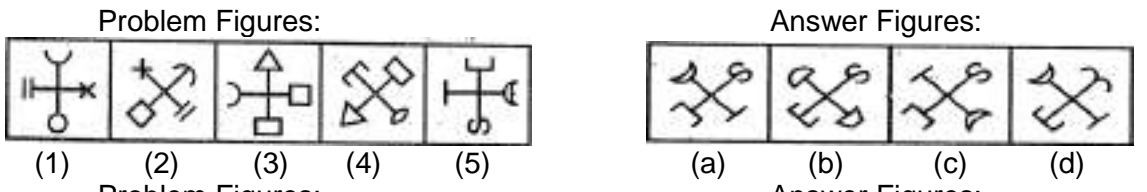

Q90.

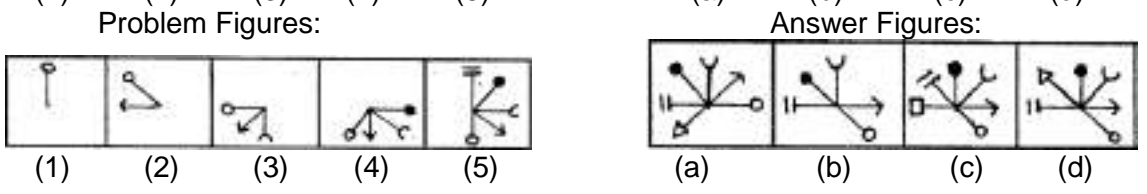

Q91-95. Each of the following questions consists of two sets of figures. Figures 1, 2, 3 and 4 constitute the Problem Set while figures a, b, c and d constitute the Answer Set. There is a definite relationship between figures (1) and (2). Establish a similar relationship between figures (3) and (4) by selecting a suitable figure from the Answer set that would replace the question mark (?) in fig.(4).

Q91.

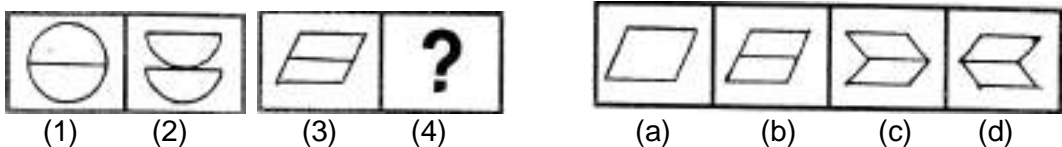

Q92.

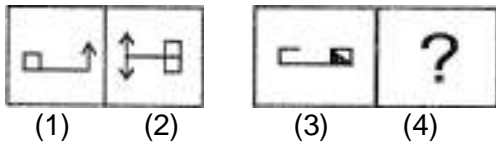

Q93.

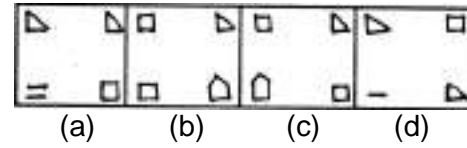
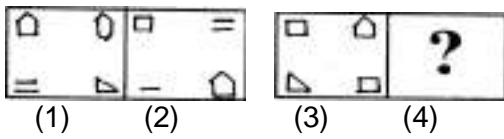

Q94.

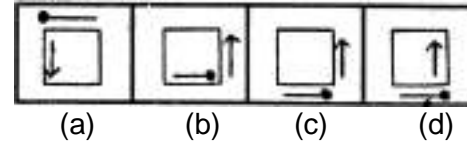
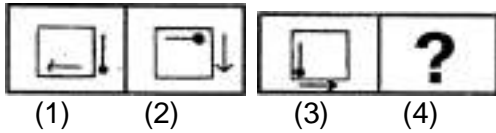

Q95.

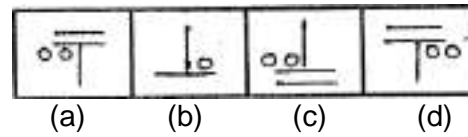
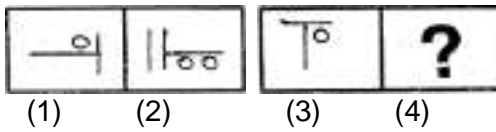

Q96-100. In each problem, out of the four figures marked (a) (b) (c) and (d) three are similar in a certain manner. However, one figure is not like the other three. Choose the figure which is different from the rest.

Q96.

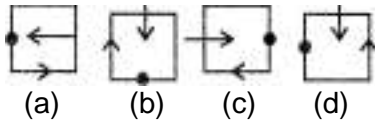

Q97.

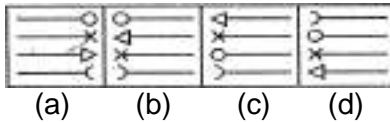

Q98.

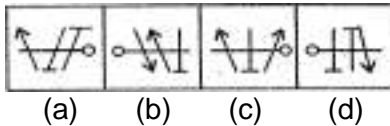

Q99.

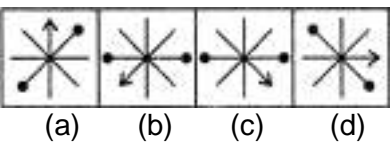

Q100.

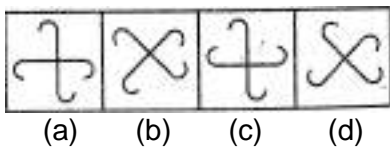

ANSWER KEYS

AFCAT Model Question Paper-I

1(d)	2(b)	3(d)	4(b)	5(a)	6(d)	7(c)	8(a)	9(d)	10(d)
11(c)	12(c)	13(b)	14(a)	15(b)	16(b)	17(c)	18(c)	19(d)	20(c)
21(c)	22(a)	23(c)	24(c)	25(c)	26(b)	27(a)	28(d)	29(a)	30(c)
31(b)	32(b)	33(d)	34(a)	35(d)	36(c)	37(a)	38(a)	39(a)	40(a)
41(a)	42(d)	43(b)	44(c)	45(c)	46(b)	47(a)	48(d)	49(b)	50(b)
51(b)	52(c)	53(d)	54(c)	55(c)	56(c)	57(d)	58(d)	59(c)	60(b)
61(c)	62(c)	63(a)	64(b)	65(a)	66(d)	67(d)	68(a)	69(c)	70(a)
71(d)	72(c)	73(c)	74(d)	75(c)	76(c)	77(c)	78(c)	79(d)	80(c)
81(d)	82(c)	83(a)	84(b)	85(d)	86(c)	87(c)	88(a)	89(d)	90(c)
91(c)	92(c)	93(a)	94(d)	95(c)	96(a)	97(b)	98(c)	99(c)	100(d)

SET – 1

Instructions for candidates

TIME ALLOTTED – 2 HRS.

1. Total No. of Questions–100. Each Question is of three marks.
2. One mark will be deducted for every wrong answer.
3. Do not write or mark on the Question Paper.
4. Question Paper to be returned before leaving the Exam Hall.

Read the following passage carefully and answer the questions given below it.

We stand poised precariously and challengingly on the razor's edge of destiny. We are now at the mercy of atom bombs and the like which would destroy us completely if we fail to control them wisely. And wisdom in this crisis means sensitiveness to the basic values of life; it means a vivid realization that we are literally living in one world where we must either swim together or sink together. We cannot afford to tamper with man's single minded loyalty to peace and international understanding. Anyone, who does it is a traitor not only to man's past and present, but also to his future, because he is mortgaging the destiny of unborn generations.

- Q1. From the tone and style of the passage it appears that the writer is-
- (a) a prose writer with a fascination for images and metaphors.
 - (b) a humanist with a clear foresight.
 - (c) a traitor who wishes to mortgage the destiny of future generations.
 - (d) unaware of the global power situation.
- Q2. The best way to escape complete annihilation in an atomic war is to-
- (a) work for international understanding and harmony.
 - (b) invent more powerful weapons.
 - (c) turn to religion.
 - (d) ban nuclear weapons.
- Q3. The phrase 'razor's edge of destiny' means a/an-
- (a) enigma that cuts through the pattern of life like the edge of a razor.
 - (b) critical situation that foreordains the future.
 - (c) sharp line of division that marks the alternative courses of action in the future.
 - (d) destiny with sharp edges.
- Q4. According to the writer, 'wisdom' on the razor's edge of destiny means:
- (a) awareness that we stand poised precariously on the razor's edge of destiny.
 - (b) determination to ban nuclear weapons.
 - (c) responsibility to the 'unborn generations'.
 - (d) awareness of the basic values of life.
- Q5. The author is concerned about the threat of nuclear weapons because he feels that-
- (a) a nuclear war will destroy human civilization.
 - (b) all countries are interlinked and one cannot escape the consequences of what happens to another country.
 - (c) the world is on the brink of disaster.
 - (d) his country is threatened by a nuclear war.

In each of the following questions, find out which part of the sentence has an error. If there is no mistake, the answer is (d) "No error".

- Q6. A person I met (a)/in the theatre (b)/was the playwright himself. (c)/No error (d).
- (a) (b) (c) (d)
- Q7. They walked (a)/besides each other (b)/in silence. (c)/No error (d).
- (a) (b) (c) (d)

- Q8. We returned to the guest house (a)/impressed by (b)/what we had seen. (c)/No error (d).
 (a) (b) (c) (d)
- Q9. The judge was convinced (a)/that neither (b)/of the five accused was guilty. (c) /No error (d).
 (a) (b) (c) (d)
- Q10. The municipality is going (a) /to built a new school (b)/near the park. (c)/ No error (d).
 (a) (b) (c) (d)

Set - 1

2

Pick out the most effective word from the given words to fill in the blank to make the sentence meaningfully complete.

- Q11. His actions had _____ pain and suffering on thousands of people.
 (a) affected (b) imposed (c) inflicted (d) deplored
- Q12. The Government will _____ all resources to fight poverty.
 (a) collect (b) exploit (c) harness (d) muster
- Q13. The children _____ crackers to celebrate the victory of their team.
 (a) burst (b) fired (c) shot (d) released
- Q14. I am _____ forward to our picnic scheduled in the next month.
 (a) seeing (b) looking (c) planning (d) thinking
- Q15. I hope you must have _____ by now that failures are the stepping stones to success.
 (a) known (b) felt (c) decided (d) realized

In each of the following choose the word most similar in meaning to the word given in capitals.

- Q16. CAUSED
 (a) Brought about (b) Brought forward (c) Brought out (d) Brought over
- Q17. PLACID
 (a) Plain (b) Clear (c) Poor (d) Calm
- Q18. AUDACIOUS
 (a) Obvious (b) Daring (c) Ardent (d) Affluent

Pick out the word that is most nearly the opposite in meaning to the word given in capitals.

- Q19. MONOLOGUE
 (a) Prologue (b) Epilogue (c) Dialogue (d) Catalogue
- Q20. DELETE
 (a) Imbibe (b) Improve (c) Insert (d) Inspire
- Q21. AMBIGUITY
 (a) Certainty (b) Clarity (c) Rationality (d) Laxity

Choose the correct answer.

- Q22. The First Battle of Panipat was fought between-
 (a) Akbar & Hemu (b) Babur and Ibrahim Lodhi
 (c) Akbar & Rana Sanga (d) Ahmad Shah Abdali & Marathas
- Q23. Fa-hien visited India during the reign of-
 (a) Chandra Gupta Maurya (b) Bindusara (c) Chandra Gupta II (d) Bimbisara

- Q24. Gandhiji's first experience with Satyagraha came up in-
(a) Dandi (b) Champaran (c) Bengal (d) Natal
- Q25. During whose tenure as the viceroy of India were the great Martyrs Bhagat Singh, Sukhdev and Rajguru hanged?
(a) Lord Curzon (b) Lord Irwin (c) Lord Minto (d) Lord Chelmsford
- Q26. The winner of the highest number of gold medals in an Olympic game is-
(a) Mark Spitz (b) Matt Biondi (c) Michael Phelps (d) Jenny Thompson
- Q27. 'Agha Khan Cup' is associated with the game of-
(a) Football (b) Hockey (c) Badminton (d) Cricket
- Q28. Usain Bolt, the 100 meters race world record holder, is from which country?
(a) Jamaica (b) U.S.A. (c) Canada (d) Nigeria
- Q29. Only two cricket players have taken 10 wickets in an innings. One is Anil Kumble. The other is-
(a) Richard Hadlee (b) Muttiah Muralidharan (c) Jim Laker (d) Andy Roberts
- Q30. 'Borlaug Award' is given every year to an Indian scientist for outstanding contribution in the field of-
(a) Medicine (b) Space (c) Applied Science (d) Agriculture
- Q31. The highest Indian gallantry award which could be given in peace time is-
(a) Ashok Chakra (b) Param Vir Chakra
(c) Kirti Chakra (d) Param Vishisht Seva Medal
- Q32. The most successful Satellite Launch Vehicle of Indian Space Programme to launch commercial satellites is known as-
(a) SLV (b) ASLV (c) PSLV (d) GSLV
- Q33. Which one of the following soils is most suitable for cotton cultivation-
(a) Red soil (b) Black soil (c) Loamy soil (d) Laterite soil
- Q34. The name of indigenously built Light Combat Aircraft is-
(a) Tejas (b) Chakra (c) Vajra (d) Trishul
- Q35. The boundary between China and India is known as-
(a) Mc Mohan Line (b) Radcliffe Line (c) Hindenberg Line (d) Line of Control
- Q36. Equinox means two days in a year when day and night are almost equal. If March 21 is an equinox which is the next?
(a) 09 October (b) 31 August (c) 23 September (d) 03 November
- Q37. UNHCR, an organisation of United Nations, was established to provide/promote-
(a) Primary Education (b) Health and Culture (c) Relief (d) Protection to refugees
- Q38. Who authored the book 'Train to Pakistan'?
(a) Salman Rushdie (b) Khushwant Singh (c) Mulk Raj Anand (d) Vikram Seth
- Q39. Vitamin necessary to prevent prolonged bleeding is-
(a) Vitamin A (b) Vitamin E (c) Vitamin D (d) Vitamin K
- Q40. The famous classical dance form of Andhra Pradesh is-
(a) Kathakali (b) Kuchipudi (c) Mohini Attam (d) Yakshaagna

- Q41. The term 'Carbon Credit' is associated with-
- (a) Coal reserve of a nation (b) Reduction of Green House Gas emissions
(c) Fossil Fuel reserve (d) Amount of CO₂ an individual emits in a year
- Q42. In a 225 meter long yard 26 trees are planted at equal distance, one tree being at each end of the yard. What is the distance between two consecutive trees?
- (a) 10 meters (b) 8 meters (c) 12 meters (d) 9 meters
- Q43. A bonus of Rs. 1000 is divided among three employees. Rohit gets twice the amount Sachin gets. Sachin gets one fifth of what Gagan gets. How much amount does Gagan get?
- (a) Rs. 500 (b) Rs. 625 (c) Rs. 750 (d) Rs. 120
- Q44. A boy was asked to multiply a number by 25. Instead, he multiplied the number by 52 and got the answer 324 more than the correct answer. The number to be multiplied was-
- (a) 12 (b) 15 (c) 25 (d) 32
- Q45. The average age of 35 students in a class is 16 years. Out of these students the average age of 21 students is 14 years. The average age of remaining students is-
- (a) 15 years (b) 17 years (c) 20 years (d) 19 years
- Q46. After replacing an old member by a new member, it was found that the average age of five members of a club is the same as it was 3 years ago. What is the difference between the age of replaced member and new member?
- (a) 2 years (b) 8 years (c) 15 years (d) 25 years
- Q47. The average salary of all the workers in a workshop is Rs. 8000. The average salary of seven technicians is Rs. 12000 and average salary of others is Rs. 6000. The total number of workers in the workshop are-
- (a) 20 (b) 21 (c) 22 (d) 23
- Q48. In an examination a candidate has to get 35% of total marks to pass. In one paper he gets 62 out of 150 and in the second 35 out of 150. How many marks should he get out of 200 marks in the third paper to pass?
- (a) 61 (b) 68 (c) 70 (d) 78
- Q49. The salary of A & B together amounts to Rs. 2000. A spends 95% of his salary and B 85% of his salary. If their savings are same what is the salary of A?
- (a) Rs. 750 (b) Rs. 1250 (c) Rs. 1500 (d) Rs. 1600
- Q50. Out of the 1000 inhabitants of a town, 60% are male of whom 20% are literate. If, amongst all the inhabitants, 25% are literate, then what percentage of the females of the town are literate?
- (a) 22.5 (b) 32.5 (c) 27.5 (d) 37.5
- Q51. A trader mixes 26 Kg of rice at Rs. 20 per kg with 30 Kg rice of another variety costing Rs. 36 per Kg. If he sells the mixture at Rs. 30 per Kg his profit will be-
- (a) -7% (b) 5% (c) 8% (d) 10%
- Q52. The difference between the cost price and sale price is Rs. 240. If the profit is 20%, the selling price is-
- (a) Rs. 1200 (b) Rs. 1440 (c) Rs. 1800 (d) Rs. 2440
- Q53. Samant bought a microwave oven and paid 10% less than Maximum Retail Price(MRP). He sold it with 30% profit on his purchase cost. What percentage of profit did he earn on MRP?
- (a) 17% (b) 20% (c) 27% (d) 32%

- Q54. The price of a scooter and a TV are in the ratio of 7:5. If the scooter costs Rs. 8000 more than a TV set, then the price of TV set is-
 (a) Rs. 20000 (b) Rs. 24000 (c) Rs. 32000 (d) Rs. 28000
- Q55. The speed of three cars is in the ratio of 5:4:6. The ratio between the time taken by them to travel the same distance is-
 (a) 5:4:6 (b) 6:4:5 (c) 10:12:15 (d) 12:15:10
- Q56. The ration between two numbers is 3:4. If each number is increased by 6 the ratio becomes 4:5. The difference between the numbers is-
 (a) 1 (b) 3 (c) 6 (d) 8
- Q57. Rs. 800 becomes Rs. 956 in 3 years at a certain rate of interest. If the rate of interest is increased by 4% what amount will Rs. 800 become in 3 years?
 (a) Rs. 1020 (b) Rs. 1052 (c) Rs. 1282 (d) Rs. 1080
- Q58. How much time will it take for an amount of Rs. 450 to gain Rs. 81 as interest, if rate of interest is 4.5% p.a on simple interest?
 (a) 4.5 years (b) 3.5 years (c) 5 years (d) 4 years
- Q59. At what rate of annual simple interest will Rs. 10000 double in 15 years?
 (a) 5.5% (b) 8% (c) 6.75% (d) 7.25%
- Q60. The value of (?) in the equation $365.089 - ? + 89.72 = 302.35$ is-
 (a) 152.456 (b) 152.459 (c) 153.456 (d) 153.459
- Q61. A sum of Rs. 312 is divided among 60 boys and some girls in such a way that each boy gets Rs. 3.60 and each girl gets Rs.2.40. The number of girls are-
 (a) 35 (b) 60 (c) 40 (d) 65

This is a test of your ability to understand words. For each question four options are given. There is only one correct answer for each question. Mark the correct answer.

- Q62. INCITE means the same as
 (a) short (b) delay (c) place (d) provoke
- Q63. SUCCUMB means the same as
 (a) aid (b) yield (c) check (d) oppose
- Q64. ANOMALOUS means the same as
 (a) disgraceful (b) formless (c) irregular (d) threatening
- Q65. FORTUITOUS means the same as
 (a) accidental (b) conclusive (c) courageous (d) prosperous
- Q66. PERMEABLE means the same as
 (a) flexible (b) variable (c) soluble (d) penetrable
- Q67. CONVOY means the same as
 (a) carry (b) flock (c) standard (d) escort
- Q68. CITE means the same as
 (a) illustrate (b) reveal (c) recollect (d) quote

- Q69. VOCATION means the same as
 (a) hobby (b) occupation (c) post (d) designation

Each of the following questions has an underlined/capitalized word. You are to indicate which one of the four choices most nearly means the same as the underlined/capitalized word.

- Q70. The benefits of the plan are likely to be transitory.
 (a) significant (b) obvious (c) temporary (d) cumulative
- Q71. The hikers found several crevices in the rocks.
 (a) cracks (b) minerals (c) canals (d) puddles
- Q72. BOOK is to CHAPTER as BUILDING is to
 (a) ELEVATOR (b) LOBBY (c) ROOF (d) STOREY
- Q73. CARROT is to VEGETABLE as
 (a) DOGWOOD is to OAK (b) FOOT is to PAW
 (c) PEPPER is to SPICE (d) SHEEP is to LAMB
- Q74. CONCAVE is to CONVEX as
 (a) CAVITY is to MOUND (b) HILL is to HOLE
 (c) OVAL is to OBLONG (d) ROUND is to POINTED
- Q75. GOWN is to GARMENT as GASOLINE is to
 (a) COOLANT (b) FUEL (c) OIL (d) LUBRICANT
- Q76. HYPER- is to HYPO- as
 (a) DIASTOLIC is to SYSTOLIC (b) OVER is to UNDER
 (c) SMALL is to LARGE (d) STALE is to FRESH
- Q77. IMMIGRATION is to EMIGRATION as
 (a) ARRIVAL is to DEPARTURE (b) FLIGHT is to VOYAGE
 (c) LEGAL is to ILLEGAL (d) MIGRATION is to TRAVEL
- Q78. OCTAGON is to SQUARE as HEXAGON is to
 (a) POLYGON (b) PYRAMID (c) RECTANGLE (d) TRIANGLE
- Q79. TELL is to TOLD as
 (a) RIDE is to RODE (b) SINK is to SANK
 (c) WEAVE is to WOVE (d) WEEP is to WEPT
- Q80. SHEEP is to LAMB as HORSE is to
 (a) COLT (b) DOE (c) FAWN (d) MARE
- Q81. IGNORE is to OVERLOOK as
 (a) AGREE is to CONSENT (b) CLIMB is to WALK
 (c) DULL is to SHARPEN (d) LEARN is to REMEMBER
- Q82. FREQUENTLY is to SELDOM as
 (a) ALWAYS is to NEVER (b) EVERYBODY is to EVERYONE
 (c) GENERALLY is to USUALLY (d) OCCASIONALLY is to CONSTANTLY

This test is designed to test your ability to visualize and manipulate objects in space. In each question, you are shown a picture of a block. To the right of the pictured block, there are five choices shown as A, B, C, D and E. Select the choice containing a block that is just like the pictured block at the left although turned in a different position.

- Q83. A B C D E

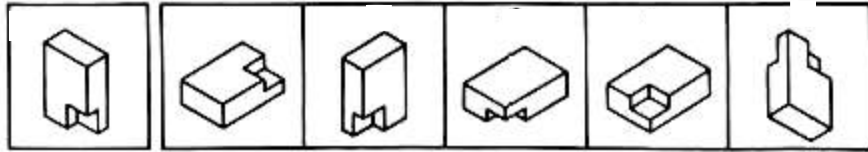

Q84.

A

B

C

D

E

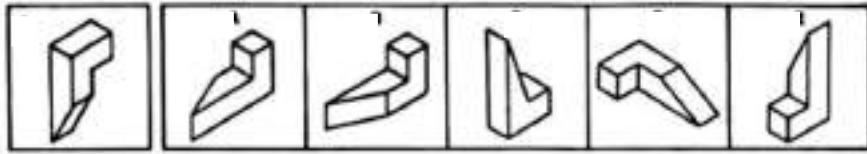

Q85.

A

B

C

D

E

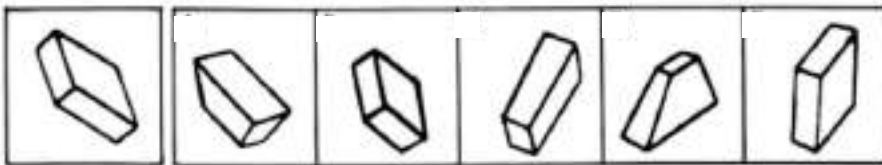

Q86.

A

B

C

D

E

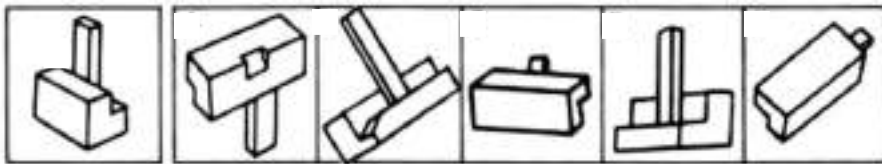

Q87.

A

B

C

D

E

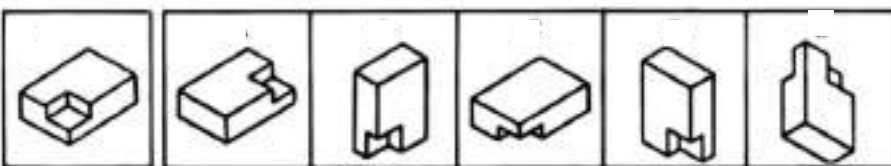

Q88.

A

B

C

D

E

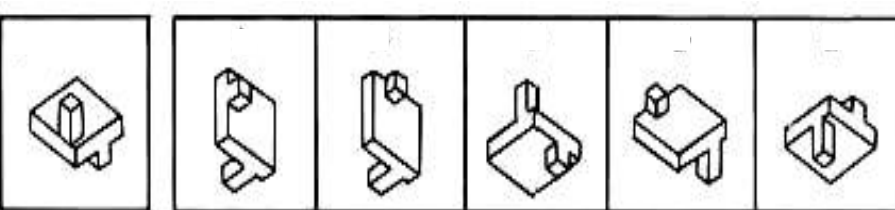

Q89.

A

B

C

D

E

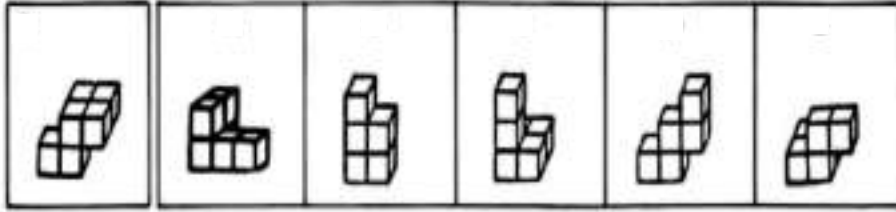

Q90.

A

B

C

D

E

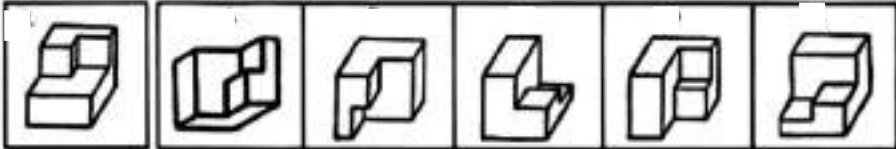

Q91.

A

B

C

D

E

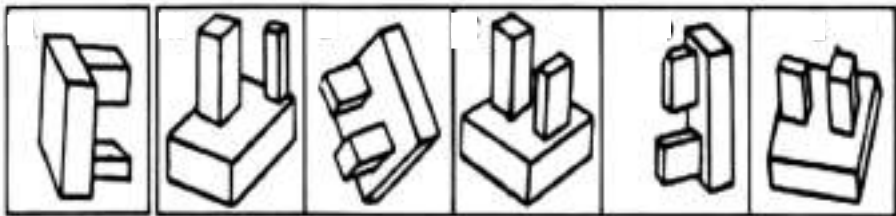

The hidden figures test is designed to perceive simple figures in complex drawings. At the top of each section are five figures lettered A, B, C, D, and E. Below these are several numbered drawings. You must determine which lettered figure is embedded in each of the numbered drawings.

A

B

C

D

E

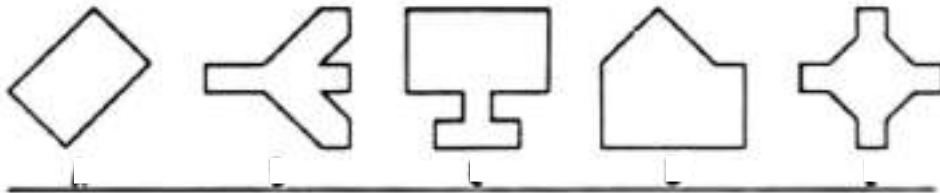

Q92.

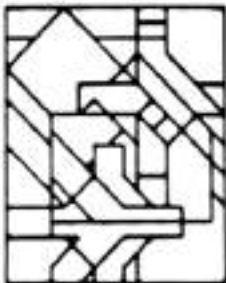

A

B

C

D

E

Q93.

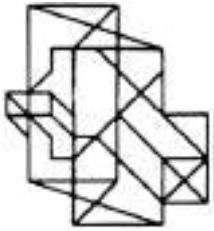

Q94.

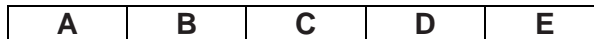
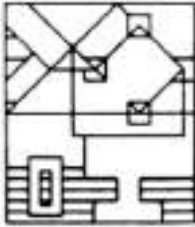

Q95.

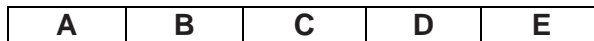
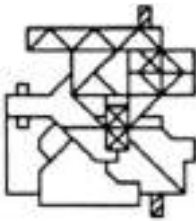

Q96.

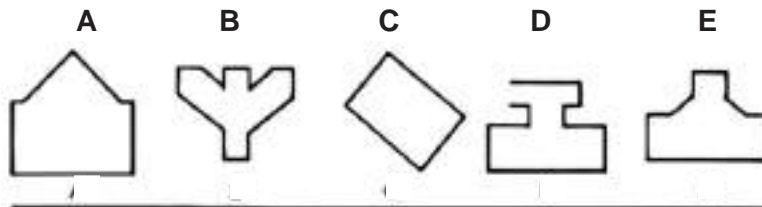
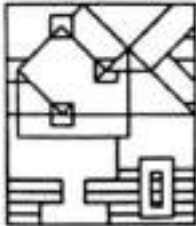

Q97.



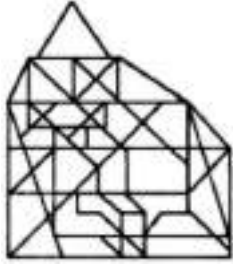

Q98.

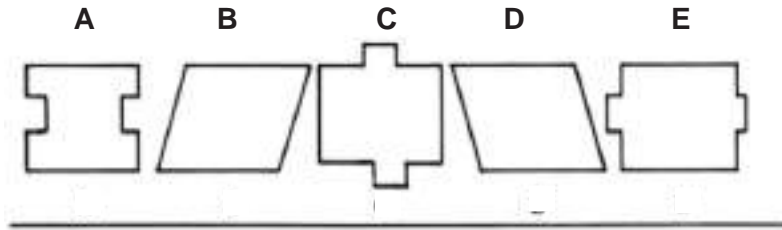
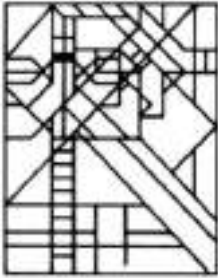

Q99.

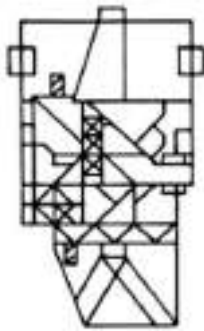

Q100.

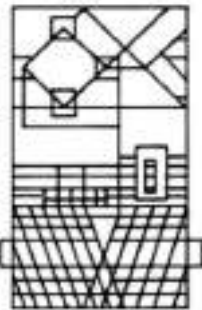

SET – 4

Instructions for candidates

TIME ALLOTTED: 2 Hrs

1. Total No. of Questions-100. Each Question is of three marks.
2. One mark will be deducted for every wrong answer.
3. Do not write or mark on the Question Paper.
4. Question Paper to be returned before leaving the Exam Hall.

Read the following passage carefully and answer the questions given below:

Pablo Picasso showed his truly exceptional talent from a very young age. His first word was lapiz (Spanish for pencil) and he learnt to draw before he could talk. He was the only son in the family and very good-looking, so he was thoroughly spoilt. He hated school and often refused to go unless his doting parents allowed him to take one of his father's pet pigeons with him.

Apart from pigeons, his great love was art and when in 1891 his father, who was an amateur artist, got a job as a drawing teacher at a college, Pablo went with him to the college. He often watched his father paint and sometimes was allowed to help. One evening his father was painting a picture of their pigeons when he had to leave the room. He returned to find that Pablo had completed the picture, and it was so amazingly beautiful and lifelike that he gave his son his own palette and brushes and never painted again. Pablo was just thirteen.

- Q1. As a boy Pablo Picasso was
(a) Ordinary looking but talented. (b) Handsome and talented.
(c) Handsome and studious. (d) Handsome and hardworking.
- Q2. He was spoilt mostly because he was
(a) A smart boy. (b) Loved by one and all.
(c) The only son in the family. (d) Always surrounded by notorious boys.
- Q3. Picasso went to school only when
(a) His friends accompanied him. (b) His father went with him.
(c) He was allowed to paint at school. (d) He was allowed to carry a pet with him.
- Q4. When his father painted in the college, Pablo
(a) Occasionally helped him. (b) Rarely helped him.
(c) Always helped him. (d) Invariably helped him.
- Q5. Pablo's father gave up painting because he
(a) Did not like the job. (b) Retired from the college.
(c) Was impressed by his son's talent. (d) Lost interest in painting.

In each of the following questions, find out which part has an error.

- Q6. The boss was irritated (a)/ by him neglecting (b)/ the duties and (c) not listening to his advice (d).
(a) (b) (c) (d)
- Q7. Each of the three (a)/ beggars were (b)/ asking for more (c)/ food to eat (d).
(a) (b) (c) (d)
- Q8. My brother sent (a)/two pairs (b)/ of shoe (c)/ from America (d).
(a) (b) (c) (d)
- Q9. The young boy said (a)/that he (b)/neither liked me (c)/nor my wife (d).
(a) (b) (c) (d)
- Q10. He was (a) /congratulated for (b)/his success in (c)/ the 100 m race (d).
(a) (b) (c) (d)

Pick up the most effective word from the given words to fill in the blanks to make the sentence meaningfully complete.

- Q11. Sanjay was _____ with divine vision to see the great battle.
(a) Demure (b) Authorized (c) Endowed (d) Uttered
- Q12. There was so much _____ material in the essay that it was difficult to get the author's message.
(a) Variegated (b) Superficial (c) Extraneous (d) Exemplary
- Q13. The world is so constructed that if you wish to enjoy its pleasures, you must also _____ its pains.
(a) Deny (b) Neglect (c) Ignore (d) Endure
- Q14. Indian press did not give _____ to the British publicity.
(a) Credence (b) Scion (c) Augury (d) Opportunity
- Q15. Travellers _____ their reservations well in advance if they want to travel during the Diwali holidays.
(a) has better to get (b) had better get (c) had to get better (d) had better got

In each of the following choose the word most similar in meaning to the word given in capitals.

- Q16. EMANCIPATE
(a) Set free (b) Exist (c) Correct morally (d) Restrain
- Q17. DECEIT
(a) Simplicity (b) Gentility (c) Sincerity (d) Dishonesty
- Q18. ADMONITION
(a) Thrash (b) Hindrance (c) Warning (d) Exhort

In each of the following choose the word most nearly opposite in meaning to the word given in capitals.

- Q19. VOCIFEROUS
(a) Laudable (b) Quiet (c) Dangerous (d) Powerful
- Q20. IMPLICATE
(a) Involve (b) Exonerate (c) Corrupt (d) Accuse

Choose the correct answer

- Q21. The person who is regarded as the greatest law giver of ancient India is
(a) Panini (b) Kautilya (c) Manu (d) Patanjali
- Q22. The immortal fame of Ashoka largely rests upon
(a) His conversion to Buddhism and its propagation.
(b) His policy for the welfare of his subjects.
(c) His work in the sphere of politics and moral teaching.
(d) His extensive conquests.
- Q23. Gandhiji started Dandi March
(a) To demonstrate against the British Empire. (b) To break the salt law.
(c) To boycott foreign goods. (d) None of the above.
- Q24. The first war of Indian Independence began on 10 May 1857 at
(a) Meerut (b) Jhansi (c) Barrackpore (d) Delhi
- Q25. The sun rises in Arunachal Pradesh two hours before it does in Dwaraka in Gujarat. This is because the former is
(a) Higher in elevation than Dwaraka and the earth rotates from West to East.
(b) Situated further North than Dwaraka and the earth rotates from West to East.
(c) Situated further East (about 30° Longitude) than Dwaraka and the earth rotates from West to East.
(d) Situated about 30° East of Dwaraka and the earth rotates from West to East.

- Q26. Srinagar is situated on the banks of the river
 (a) Ravi (b) Sutlej (c) Jhelum (d) Chenab
- Q27. The areas in India that receive approximately an average of more than 200 cms of rainfall annually are
 (a) Meghalaya, Assam, Nagaland, Arunachal Pradesh.
 (b) Orissa, Madhya Pradesh, Gujarat, Maharashtra.
 (c) Meghalaya, Assam, Rajasthan, Jammu & Kashmir.
 (d) Meghalaya, Delhi, Punjab, Rajasthan.
- Q28. Isotherms are imaginary lines drawn on a map which connect places of equal
 (a) Atmospheric pressure (b) Humidity (c) Rainfall (d) Temperature
- Q29. Jim Corbett National Park is situated in which state?
 (a) Arunachal Pradesh (b) Himachal Pradesh
 (c) Andhra Pradesh (d) Uttaranchal
- Q30. Which one of the following statement regarding the sun is correct?
 (a) The sun is composed mainly of hydrogen.
 (b) Its energy is generated by nuclear collision in its interior.
 (c) It is calculated that the sun consumes about a trillion pounds of hydrogen every second.
 (d) All of the above.
- Q31. Supersonic speed is speed greater than the speed of sound (in air at sea level) that is to say around _____ miles/hour.
 (a) 760 (b) 860 (c) 960 (d) 1060
- Q32. Yoga sutra was written by
 (a) Vatsyayana (b) Pathanjali
 (c) Bhartrihari (d) Maharshi Mahesh
- Q33. The National Institute of Oceanography is located at
 (a) Trivandrum (b) Panaji (c) Cochin (d) Mangalore
- Q34. An aeroplane rises because
 (a) Of upward reaction of air.
 (b) The density of air above the plane is less than below it.
 (c) The pressure above its wings is less than the pressure below them.
 (d) Its nose points upwards.
- Q35. Rocks formed on the solidification of molten matter are called
 (a) Metamorphic rocks (b) Sedimentary rocks
 (c) Volcanic rocks (d) Igneous rocks
- Q36. The pioneer of Atomic energy in India is
 (a) Homi J Bhabha (b) Vikram Sarabhai
 (c) C.V. Raman (d) C.K. Naidu
- Q37. Which one of the following statements regarding FIFA World Cup 2010 is not correct?
 (a) South Africa became the first host nation to fail to qualify for the tournament's second round.
 (b) The tournament was the culmination of a qualification process that began in August 2007.
 (c) This is the first time that the tournament was hosted by an African nation.
 (d) Zakumi, the official mascot for the FIFA World Cup, 2010 is an African bush elephant.
- Q38. The first Indian to win the World Amateur Snooker Championship is
 (a) Om Agarwal (b) Geet Sethi
 (c) Michael Ferreira (d) Wilson Jones
- Q39. The first person to win the Arjuna award for badminton is

- (a) Pullela Gopichand (b) Prakash Padukone
(c) Nandu Natekar (d) Farook Engineer

- Q40. The sport which requires the largest field is
(a) Football (b) Cricket (c) Hockey (d) Polo

Find the odd one out.

- Q41. (a) Advice (b) Counsel (c) Direct (d) Suggest
Q42. (a) Tumble (b) Topple (c) Crumble (d) Sprain
Q43. (a) Sobriquet (b) Alias (c) Pseudonym (d) Anonymous
Q44. (a) Mumbai (b) Goa (c) Visakhapatnam (d) Thiruvananthapuram
Q45. (a) Petrol (b) Acetone (c) Mercury (d) Kerosene

In the following questions the words given bear a certain relationship. Your task is to find out from the choices the words with the same relationship.

- Q46. Hope: Despair
(a) Work : Failure (b) Worship : Adore
(c) Cow : Milk (d) Encourage : Dishearten
- Q47. Army : Logistics
(a) War: Logic (b) Soldiers : Students
(c) Business : Strategy (d) Team : Individual
- Q48. Bouquet : Flower
(a) Skin : Body (b) Chain : Link
(c) Product : Factory (d) Page : Book
- Q49. Revenge: Vendetta
(a) Sleep: Dream (b) Sun: Moon
(c) Envy : Jealousy (d) Heaven : God
- Q50. Refine : Style
(a) Retouch : Photograph (b) Paint : Wall
(c) Compose : Song (d) Author : Book
- Q51. Fear : Tremble
(a) Hand: Shake (b) Heat : Perspire
(c) Distance : Walk (d) Evening : Star
- Q52. Condone: Offence
(a) Punish: Criminal (b) Mitigate: Penitence
(c) Overlook: Aberration (d) Ignore: Loyalty
- Q53. Plant : Flower
(a) Face : Eye (b) Stem : Tree
(c) Chair : Sofa (d) Blades : Grass
- Q54. Protoplasm : Cell
(a) Fibre : Plastic (b) Coin : Money
(c) Chemistry : Elements (d) Chain : Link
- Q55. Nalanda : Takshshila
(a) Venus : Mars (b) University : College
(c) Office : Department (d) Ship : Cargo

In the following questions (Q56-60) the first word is related to the second in the same way as the third word is related to the fourth. In the given problems either the third or the fourth word is missing and is left blank. You have to choose the correct word to fill in the blank.

- Q56. Foot is to Man as Hoof is to _____.
(a) Dog (b) Cow (c) Cat (d) Rabbit
- Q57. Broad is to Narrow as _____ is to Lane.

- Q58. Back is to Backbone as Belly is to _____.
 (a) Footpath (b) Field (c) Pavement (d) Road
 (a) Throat (b) Ribs (c) Heart (d) Navel
- Q59. Ankle is to Knee as Wrist is to _____.
 (a) Elbow (b) Finger (c) Hand (d) Foot
- Q60. Sting is to Bee as _____ is to Snake.
 (a) Slithering (b) Rats (c) Poison (d) Fangs
- Q61. Hari's income is 20% more than Madhu's income. Madhu's income is less than Hari's income by
 (a) 15% (b) 16.66 % (c) 20% (d) 22.25%
- Q62. A sum of money lent out at simple interest doubled itself in 20 years. In how many years will it triple itself?
 (a) 28 years (b) 30 yrs (c) 40 yrs (d) 35 yrs
- Q63. Which of the following fractions are in ascending order?
 (a) $\frac{2}{3}, \frac{3}{5}, \frac{7}{9}, \frac{9}{11}, \frac{8}{9}$ (b) $\frac{3}{5}, \frac{2}{3}, \frac{9}{11}, \frac{7}{9}, \frac{8}{9}$
 (c) $\frac{3}{5}, \frac{2}{3}, \frac{7}{9}, \frac{9}{11}, \frac{8}{9}$ (d) $\frac{8}{9}, \frac{9}{11}, \frac{7}{9}, \frac{2}{3}, \frac{3}{5}$
- Q64. $337.62 + 8.591 + 34.4 = ?$
 (a) 370.611 (b) 380.511 (c) 380.611 (d) 426.97
- Q65. Find the sum of :- $\frac{1}{9} + \frac{1}{6} + \frac{1}{12} + \frac{1}{72}$
 (a) $\frac{3}{5}$ (b) $\frac{3}{2}$ (c) $\frac{3}{8}$ (d) $\frac{4}{7}$
- Q66. Find the average of all the numbers between 6 and 34 which are divisible by five.
 (a) 18 (b) 20 (c) 24 (d) 30
- Q67. The average of first 80 natural numbers is
 (a) 40 (b) 41 (c) 40.5 (d) 142
- Q68. If the sum of a few numbers is 450 and their mean is 50 and if another number 100 is included, the mean would become
 (a) 55 (b) 60 (c) 75 (d) 150
- Q69. ?% of $932 + 30 = 309.6$
 (a) 25 (b) 30 (c) 35 (d) 40
- Q70. The difference between a number and its two-fifth is 510. What is 10% of that number?
 (a) 12.75 (b) 85 (c) 204 (d) None
- Q71. One litre of water is evaporated from 6 litres of a solution containing 5% salt. The percentage of salt in the remaining solution is
 (a) 16% (b) 5% (c) 4% (d) 6%
- Q72. A shopkeeper professes to sell all things at a discount of 10% but increases the Selling Price of each article by 20%. His gain on each article is
 (a) 6% (b) 8% (c) 10% (d) 12%
- Q73. If the selling price of an article is $\frac{4}{3}$ rd of its cost price, the profit in transaction is
 (a) 16.75% (b) 20.50% (c) 25.50% (d) 33.33%
- Q74. If selling price is doubled, the profit triples. Find the profit percent.
 (a) 66.66 (b) 100 (c) 105.33 (d) 120
- Q75. If $\frac{4}{5}$ th of an estate is worth ` 16,800, then the value of $\frac{3}{7}$ th of the estate is
 (a) ` 9000 (b) ` 21000 (c) ` 72000 (d) ` 90000
- Q76. If $\frac{a}{b} = \frac{3}{4}$ and $8a + 5b = 22$, then the value of 'a' is
 (a) 1 (b) $\frac{1}{2}$ (c) $\frac{3}{2}$ (d) $\frac{3}{4}$
- Q77. If (a-b) is 6 more than (c+d) and (a+b) is 3 less than (c-d), then the value of (a-c) is
 (a) 0.5 (b) 1.0 (c) 1.5 (d) 2.0

Q78. Two numbers are in the ratio 7:8. If 3 is added to each of them their ratio becomes 8:9. The numbers are

- (a) 14, 16 (b) 24, 27 (c) 21, 24 (d) 16, 18

Q79. The sum of three numbers is 98. If the ratio of the first to the second is 2:3 and that of the second to the third is 5:8, then the second number is

- (a) 20 (b) 30 (c) 48 (d) 58

Q80. A certain amount was divided between Sita and Gita in the ratio 9:8. If Sita's share was 4500 then the amount is

- (a) 9000 (b) 8500 (c) 6750 (d) 9025

Find out which of the figures (1), (2), (3) and (4) can be formed from the pieces given in figure (X) (Q81 to Q84).

Q81.



(X)

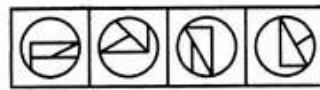

(1) (2) (3) (4)

- (a) 1 (b) 2 (c) 3 (d) 4

Q82.

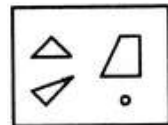

(X)

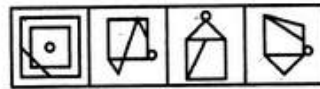

(1) (2) (3) (4)

- (a) 1 (b) 2 (c) 3 (d) 4

Q83.



(X)

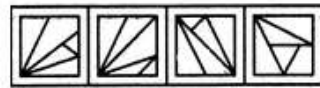

(1) (2) (3) (4)

- (a) 1 (b) 2 (c) 3 (d) 4

Q84.

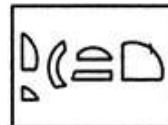

(X)



(1) (2) (3) (4)

- (a) 1 (b) 2 (c) 3 (d) 4

Q85. Find out how the key figure (X) will look like after rotation.







(X)



(1) (2) (3) (4)

- (a) 1 (b) 2 (c) 3 (d) 4





In each of the following questions (Q.86-90) select a figure from amongst the four alternatives, which when placed in the blank space of figure (X) would complete the pattern.

Q86.     

(a) 1 (b) 2 (c) 3 (d) 4

Q87.     





(a) 1 (b) 2 (c) 3 (d) 4

Q88.     

(a) 1 (b) 2 (c) 3 (d) 4





Q89.     

(a) 1 (b) 2 (c) 3 (d) 4





Q90.     

(a) 1 (b) 2 (c) 3 (d) 4





In each of the following questions (Q91-95) you are given a figure (X) followed by four alternative figures (1), (2), (3) and (4) such that figure (X) is embedded in one of them. Trace out the alternative figure which contains fig. (X) as its part.

Q91.     

(a) 1 (b) 2 (c) 3 (d) 4

Q92.     

(a) 1 (b) 2 (c) 3 (d) 4

Q93.     

(a) 1 (b) 2 (c) 3 (d) 4

Q94.



(a) 1

(b) 2

(c) 3

(d) 4

Q95.

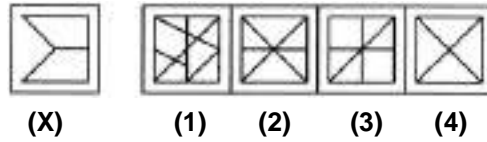

(a) 1

(b) 2

(c) 3

(d) 4

8

Set-IV

In each of the following questions (Q96-100) find out which of the answer figures (1), (2), (3) and (4) completes the figure matrix

Q96.

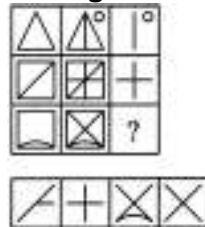

(a) 1

(b) 2

(c) 3

(d) 4

Q97.

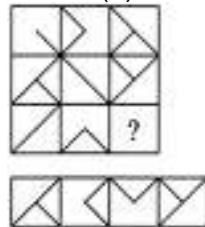

(a) 1

(b) 2

(c) 3

(d) 4

Q98.

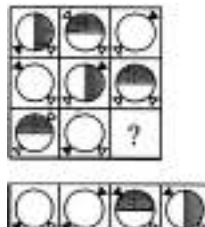

(a) 1

(b) 2

(c) 3

(d) 4

Q99.

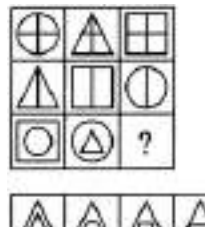

(1) (2) (3) (4)

(a) 1

(b) 2

(c) 3

(d) 4

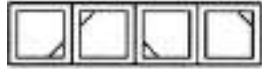
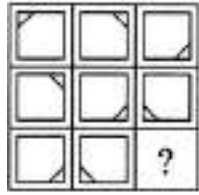

(1) (2) (3) (4)

Q100.

(a) 1

(b) 2

(c) 3

(d) 4

AFCAT VII

Instructions for candidatesTIME ALLOTTED: 2 Hrs

1. Total No. of Questions-100. Each Question is of three marks.
2. One mark will be deducted for every wrong answer.
3. Do not write or mark on the Question Paper.
4. Question Paper to be returned before leaving the Exam Hall.

Read the following passage carefully and answer the questions given below:

We shall go on to the end, we shall fight in France, we shall fight on the seas and oceans, we shall fight with the growing confidence and strength in the air, we shall defend our island whatever the cost may be, we shall fight on the beaches, we shall fight on the landing grounds, we shall fight in the fields and in the streets, we shall fight in the hills. We shall never surrender, and even if this island or a large part of it were subjugated and starving, then our empire beyond the seas would carry on the struggle, until the New World steps forth to the rescue and the liberation of the Old.

- Q1. On the basis of the passage which of the following statements may be said to be correct?
- (a) The speaker is encouraging his men for the conquest of France
 - (b) The speaker is an aggressive and maniacal war-monger
 - (c) The speaker is not satisfied with the conquest of the island
 - (d) The speaker is a patriot urging the defence of his motherland
- Q2. The speaker in the passage wants to go on fighting because:-
- (a) He is a raving lunatic
 - (b) He is in a state of utter despair
 - (c) He expects help from other quarters
 - (d) He is the leader of a suicide squad
- Q3. Which of the following pair of the phrases helps best to bring out the intention of the speaker?
- (a) "Go on to the end", "shall never surrender"
 - (b) "Growing confidence", "subjugated and starving"
 - (c) "Subjugated and starving", "fighting on the landing ground"
 - (d) "Fighting in the streets", "subjugated and starving"
- Q4. The passage consists of repetitive patterns in syntax and vocabulary. The effect of this style is that it -
- (a) Reveals the speaker's defects in giving a speech
 - (b) Produces the impression of bad poetry
 - (c) Conveys the speaker's helpless situation
 - (d) Reinforces the speaker's basic intention
- Q5. The tone of the speaker is:-
- (a) Pleading and urging
 - (b) Inspiring and encouraging
 - (c) Discouraging and gloomy
 - (d) Menacing and bullying

In each of the following, choose the word most similar in meaning to the word given in capitals.

- Q6. 'MEDDLE'
- (a) Disregard (b) Overlook (c) Interfere (d) Free

Continued 2....

- Q7 'ABJURE'
 (a) Renounce (b) Run off secretly (c) Abide (d) Discuss
- Q8 'ESTRANGE'
 (a) Endange: (b) To become puzzling (c) Miscalculate (d) Alienate

In each of the following, choose the word which is nearly opposite in meaning to the word given in capitals

- Q9 'DEROGATORY'
 (a) Conferred (b) Immoderate (c) Praising (d) Private
- Q10 'WANE'
 (a) Wider (b) Poor (c) Swell (d) Tight

In each of the following questions, find out which part has an error

- Q11 The police had re-arrested the thief (a) before he got into my house (b) last night (c)
- Q12 The man who (a) they thought to be (b) a gentleman turned out (c) to be a rogue (d)
- Q13 I told him on his face (a) that he could not hope (b) to pass the stringent (c) medical examination of the Services Selection Board. (d)
- Q14 Mohan is one of those boys (a) who has expressed (b) willingness for joining (c) the educational tour (d)
- Q15 I may spend (a) this summer vacations (b) with one of my friends (c) in the back waters of Kerala. (d)

Pick up the most effective word from the given words to fill in the blanks to make the sentence meaningfully complete

- Q16 According to the weather _____ it is going to be cloudy today
 (a) Announcement (b) Indication (c) Prediction (d) Forecast
- Q17 The villagers _____ the murder of their leader by burning the police van
 (a) Protested (b) Avenged (c) Mourned (d) Consolated
- Q18 While on a routine flight, the aircraft was hit by a missile and _____ into flames
 (a) Fired (b) Burst (c) Caught (d) Engulfed
- Q19 Hari got the company car for a _____ price as he was the senior most employee in the company
 (a) Reduced (b) Discounted (c) Fixed (d) Nominal
- Q20 The untidy behavior of the soldiers _____ their commander.
 (a) Clashed (b) Aggrieved (c) Incensed (d) Impeached
- Q21 Who accorded the title 'Mahatma' to Mah. Gandhi?
 (a) Sardar Patel (b) Nehru (c) Sarojini Naidu (d) Rajendra Prasad Tagore
- Q22 The Non-Co-operation Movement started in which year?
 (a) 1900 (b) 1921 (c) 1940 (d) 1930
- Q23 During the Middle Ages education was confined only to
 (a) Kshatriyas (b) Brahmins (c) Peasants (d) Soldiers
- Q24 Who among the following was responsible for the spread of Buddhism in Sri Lanka?
 (a) Ashoka (b) Mahaveera (c) Paravanthi (d) Chandra Gupta Maurya
- Q25 The elements which have low value of ionization potential are strong
 (a) Oxidising agents (b) Reducing agents
 (c) Corrosive and flouting agents depending upon the redox potential (d) None of these

- Q.26. Wayne Rooney, the famous footballer, hails from which country?
 (a) Italy (b) Brazil (c) Argentina (d) England
- Q.27. The official song 'WakaWaka' of FIFA World Cup held in the year 2010 at South Africa was sung by which popular singer?
 (a) Madonna (b) Destiny Child (c) Shakira (d) Rihanna
- Q.28. In the year 2011, the ace badminton player Saina Nehwal was honoured with which sports award?
 (a) Dronacharya award (b) Rajiv Gandhi Khe. Prina award
 (c) Arjun award (d) None of these
- Q.29. Term 'Visible Horizon' in astronomy is defined as -
 (a) The circle of contact of the earth and the cone of visual rays passing through the meridian of the place.
 (b) The circle of contact of the earth and the cone of visual rays not passing through the meridian of the place.
 (c) The circle of contact of the earth and the cone of visual rays passing through the point of observation.
 (d) The circle of contact of the earth and the cone of visual rays not passing through the point of observation.
- Q.30. NREGA stands for -
 (a) National Revenue Engagement Guarantee Association
 (b) National Revenue Employment Guarantee Act
 (c) National Rural Employment Guarantee Association
 (d) National Rural Employment Guarantee Act
- Q.31. River Satluj originates from -
 (a) Northern slopes of the Kailash range (b) Spring at Verinag
 (c) Rakas Lake (d) Amarkantak plateau.
- Q.32. Limonite ore is the ore of which metal?
 (a) Iron (b) Aluminium (c) Zinc (d) Cobalt
- Q.33. Black revolution relates to which of the following?
 (a) Self-dependence in foodgrains production (b) Self-dependence in milk production
 (c) Self-dependence in petroleum/crude oil (d) None of these
- Q.34. Kargil is the unmanned bomber aircraft of -
 (a) Iraq (b) Iran (c) Turkey (d) Pakistan
- Q.35. Who is the author of book 'Keeping the Faith: Memoirs of a Parliamentarian'?
 (a) David Darnold (b) Raja Shekhasah (c) Ragnav Bahl (d) Somnath Chatterjee
- Q.36. _____ is a thyroid hormone which controls the balance of calcium in the body
 (a) Calcitonin (b) Thyroxine (c) Calmodulin (d) all of these
- Q.37. The cell wall in plants is interrupted by narrow pores carrying fine strands of cytoplasm which interlink the contents of the cells. These strands are called -
 (a) Plasmahole (b) Microvilli (c) Plasmodesmata (d) Plasmalemma
- Q.38. Who is the cricketer bestowed with an honorary commission in the Territorial Army?
 (a) Sachin Tendulkar (b) Kapil Dev (c) Virendra Sehwag (d) Harbhajan Singh
- Q.39. The transport phenomenon occurs only in _____ state of a gas and is _____
 (a) Non-equilibrium, irreversible (b) Non-equilibrium, reversible
 (c) equilibrium, irreversible (d) equilibrium, reversible

- Q40. Which of the following compounds form nitrites with nitrous acid?
 (a) Primary amines (b) Secondary amines
 (c) Tertiary amines (d) All of these
- Q41. The number whose square is equal to the difference of the squares of 37 and 23 is
 (a) 45.09 (b) 28.58 (c) 47.09 (d) 28
- Q42. The average age of 8 men is increased by 4 years when one of them whose age is 30 years is replaced by a new man. What is the age of new man?
 (a) 55 Years (b) 52 Years (c) 42 Years (d) 64 Years
- Q43. A vessel, full of water, weighs 24 Kg. When the vessel is 1/4 full it weighs 9 kg. Find the weight of empty vessel
 (a) 4 Kg (b) 5 Kg (c) 8 kg (d) 3 kg
- Q44. If $a-b = 4$ and $ac = 45$ find the value of a^2-b^2 .
 (a) 604 (b) 376 (c) 253 (d) 159
- Q45. If $a/(a-b) = 5/21$, what is $(a+b)/(a-b)$ equal to?
 (a) 13/9 (b) 23/11 (c) 14/5 (d) 21/9
- Q46. $\frac{(798+579)^2 - (798-579)^2}{(798 \times 579)} = ?$
 (a) 2 (b) 6 (c) 4 (d) 8
- Q47. A man's average monthly expenditure for the first four months of the year was ₹ 231.25. For the next five months the average monthly expenditure was ₹ 22.75 more than what it was during the first four months. If the person spent ₹ 605 in all during the remaining three months of the year, find what percentage of his annual income of ₹ 3500 did he save in the year?
 (a) 10% (b) 15% (c) 20% (d) 25%
- Q48. The average age of students of a class is 15.8 years. The average age of boys in the class is 16.4 years and that of the girls is 15.4 years. The ratio of the number of boys to the number of girls in the class is:
 (a) 1:2 (b) 2:3 (c) 3:4 (d) 3:5
- Q49. 18 buckets of water fill a tank when the capacity of each bucket is 6 litres. How many buckets will be needed to fill the same tank if the capacity of the bucket is 12 litres?
 (a) 12 (b) 13.5
 (c) 24 (d) can not be determined due to insufficient data
- Q50. Srinivasan invests two equal amounts in two banks giving 8% and 12% rate of interest respectively. At the end of year the interest earned is Rs 1500. Find the sum invested in each
 (a) ₹ 8500 (b) ₹ 15000 (c) ₹ 7500 (d) ₹ 17,000
- Q51. The simple interest accrued on a sum of money at the end of four years is 1/5th of its principal. What is the rate of interest per annum?
 (a) 4% (b) 5% (c) 6% (d) Inadequate data
- Q52. A sum of ₹ 2600 is lent out into two parts: one at 9% and another at 7%. If the total annual income is ₹ 206, find the money lent at 7%.
 (a) ₹ 1400 (b) ₹ 900 (c) ₹ 1800 (d) ₹ 1200
- Q53. In an election between two candidates, 70% of the voters cast their votes, out of which 2% of the votes were declared invalid. A candidate got 7203 votes which was 60% of the total valid votes. Find the total number of voters enrolled in that election.
 (a) 18350 (b) 17500 (c) 17000 (d) 1200

- Q54. If the price of kerosene be raised by 11% find by how much percent a house holder must reduce his consumption of kerosene so as not to increase his expenditure?
 (a) 11% (b) 9.9% (c) 11.09% (d) 8.25%
- Q55. 75 pupils from a school appeared for an examination and 80% of them passed. Another school entered 10 more pupils than the first school and five pupils less than the first school passed. The pass % of in the second school was:-
 (a) 75% (b) 84% (c) 72% (d) 64.7%
- Q56. Divide ₹ 80 in the proportion of 3:6:7
 (a) ₹ 10, ₹ 35, ₹ 40 (b) ₹ 15, ₹ 30, ₹ 35
 (c) ₹ 15, ₹ 35, ₹ 30 (d) ₹ 10, ₹ 40, ₹ 35
- Q57. Calculate the amount on ₹ 1575 for 2 years at 4% per annum, compounded yearly.
 (a) ₹ 676 (b) ₹ 776 (c) ₹ 1778 (d) ₹ 2028
- Q58. If x varies as y and $x = 8$ when $y = 15$ then the value of x when $y = 10$ is -
 (a) 5 (b) $15/8$ (c) $8/15$ (d) $15/3$
- Q59. In a mixture of 60 litres, the ratio of milk and water is 2:1. What amount of water must be added to make the ratio of milk and water as 1:2?
 (a) 42 Litres (b) 56 Litres (c) 60 Litres (d) 77 Litres
- Q60. A sum of ₹ 10,000 is lent partly at 6% and the remaining at 10% p.a. If the yearly interest on the average is 9.2%, the money lent at 10% is -
 (a) ₹ 8000 (b) ₹ 3500 (c) ₹ 5000 (d) ₹ 2000

Direction:- Choose the word which is least like the other words in the group

- Q61. (a) Garo (b) Khasi (c) Kangra (d) Jayantia
 Q62. (a) Virgo (b) Pisces (c) Cancer (d) Orion
 Q63. (a) Shoulder (b) Foot (c) Finger (d) Elbow
 Q64. (a) Canoe (b) Dingy (c) Yacht (d) Igloo
 Q65. (a) Inn (b) Club (c) Motel (d) Hostel

Directions:- The following questions consist of two words that have a certain relationship to each other, followed by four alternatives. Select the best alternative that has the same relationship as the original pair of words.





- Q66. Liquor : Drink
 (a) Bread : Butter (b) Tea : Beverage
 (c) Sniff : Inhale (d) Water : Sip
- Q67. Evaporation : Cloud
 (a) Mountain : Snow (b) Book : Pages
 (c) Pressure : Atmosphere (d) Tension : Breakdown
- Q68. Barrel : Vial
 (a) Book : Pamphlet (b) Book : Reader
 (c) Brochure : Compiler (d) Length : Height
- Q69. Cream : Cosmetics
 (a) Tiger : Forest (b) Mountain : Valley
 (c) Magazine : Editor (d) Teak : Wood
- Q70. Carnivore : Herbivore
 (a) Flesh : Plant (b) Horse : Lion
 (c) Camel : Giraffe (d) Animal : Bird

Direction: Three words in bold letters are given in each question, which have something in common among themselves. Out of the four given alternatives, choose the most appropriate description about these three words.

- Q71. **Hamlet** : **Macbeth** : **Faustus**
 (a) They were Princes (b) They are plays by Shakespear.
 (c) They are characters from various dramas (d) They were romantic heroes

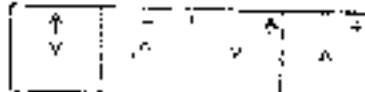
- Q72. **Vesuvius : Etna : Kilimanjaro**
 (a) These are sites of volcanoes. (b) These are island countries.
 (c) These are hills of Italy (d) These lie in polar region
- Q73. **Knot : Watt : Fathom**
 (a) The terms are used by sailors (b) The terms are used for casting dictionary
 (c) The terms are connected with rope (d) They are units of measurement.
- Q74. **Baruni : Digboi : Anikeshwar**
 (a) They are famous for oil fields. (b) They are famous religious places
 (c) They are tourist places of South India (d) They are famous for handicrafts
- Q75. **Knight : Rook : Bishop**
 (a) These are missionaries. (b) These are churchmen
 (c) These are chessmen (d) These are ranks of military
- Q76. **Abhi Bhattacharya : Utpal Dutt : Satyajit Ray**
 (a) They are character actors. (b) They are directors of Bengali movies
 (c) They are famous poets and writers. (d) These personalities belong to Bengal
- Q77. **Voodoo : Sorcery : Necromancy**
 (a) They are ancient arts found in sculptures.
 (b) They are terms connected with black magic
 (c) They are ancient scripts.
 (d) They are means of communication of pre-historic age.
- Q78. **Rourkela : Bokaro : Durgapur**
 (a) They are steel plants (b) They have coal mines
 (c) They have atomic power plants (d) They are on the sea coast
- Q79. **Spinach : Fenugreek : Celery**
 (a) These are cactus plants (c) These are wild plants
 (c) These are wild flowers (d) These are leafy vegetables
- Q80. **Yogi : Ghalib : Kabir**
 (a) They were social reformers (c) They were famous poets.
 (c) They were saints (d) They were yoga instructors

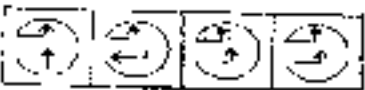
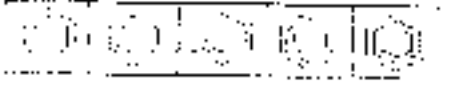
Direction: There are two sets of figures namely the Problem figures containing five figures 1, 2, 3, 4, 5 and answer figures (a), (b), (c), (d). You have to select one figure from the Answer figures which will continue the same series as given in the Problem figures.

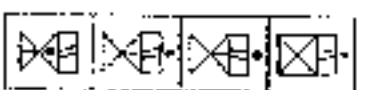
- Q81.  
 (1) (2) (3) (4) (5) (a) (b) (c) (d)
- Q82.  
 (1) (2) (3) (4) (5) (a) (b) (c) (d)
- Q83.  
 (1) (2) (3) (4) (5) (a) (b) (c) (d)
- Q84.  
 (1) (2) (3) (4) (5) (a) (b) (c) (d)

Continued.

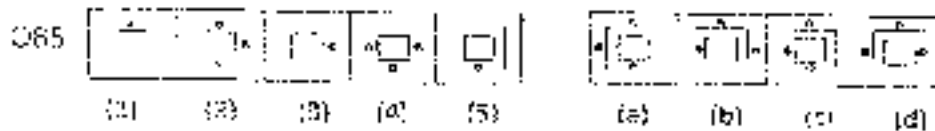

Direction: The following situations involve a cluster of three or more geometrical figures, having one or more dots placed at any point inside the cluster. This cluster is followed by a set of four alternative figures each composed of a cluster of the same type of figures. Now, for each dot we have to observe the region in which it is enclosed i.e. in which of the geometrical figure this region is common.

From amongst the figures marked (a), (b), (c) and (d), select the figure which satisfies the same conditions of placement of the dot as in fig. (X).

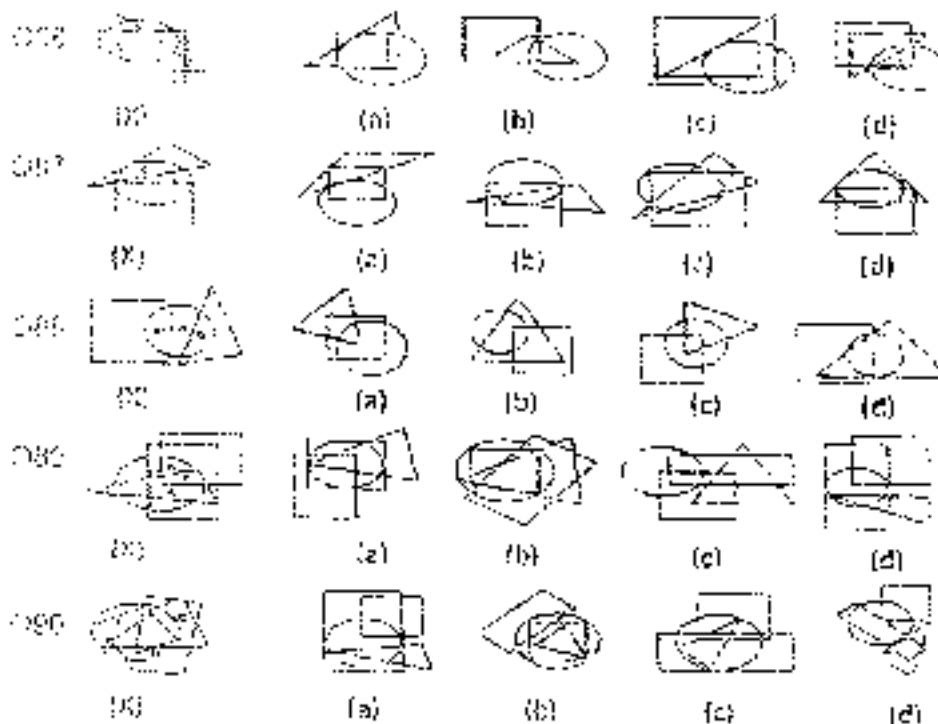

Direction: In this portion, a figure is given as an original figure (X) followed by four answer figures. The original figure is embedded or hidden in one of the answer figures (a, b, c & d). Select the alternative that carries the correct figure which clearly shows the embedded portion of the original figure.

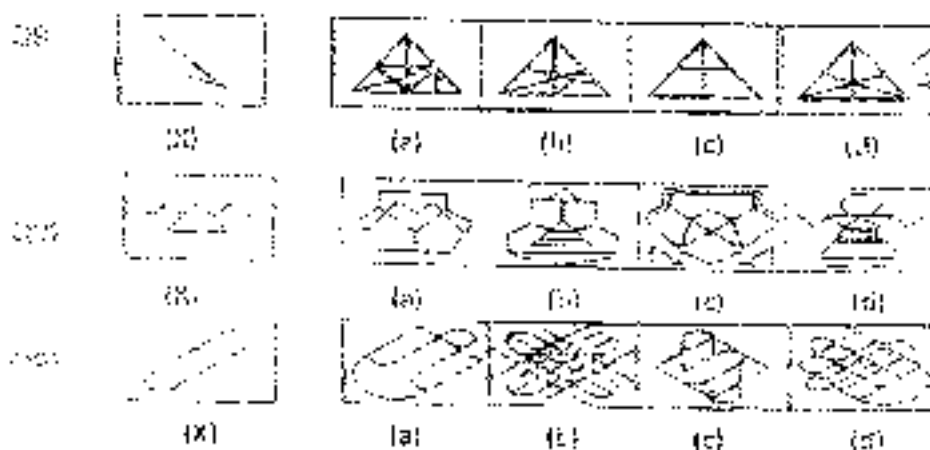

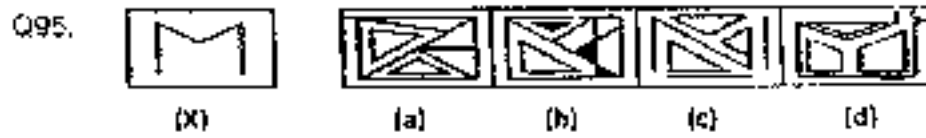
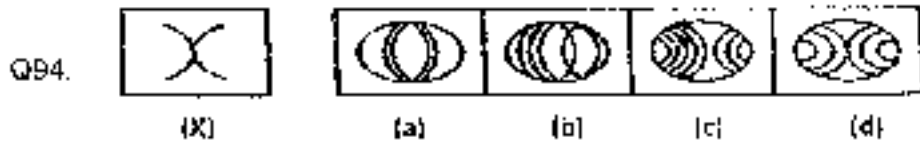

Direction: In each of the following questions, a part of the figure is missing. Find out from the given options (a), (b), (c) or (d), the right figure to fit in the missing figure (X).

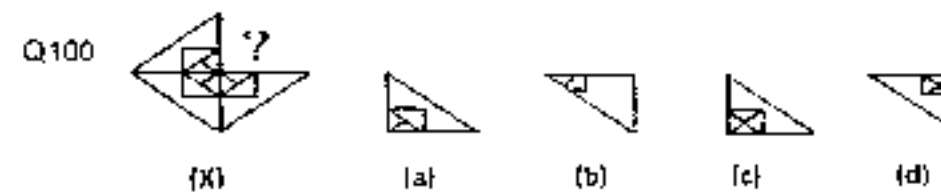
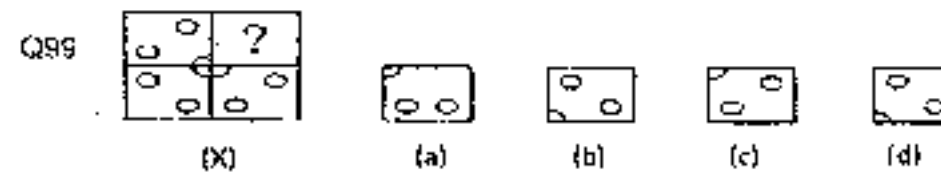
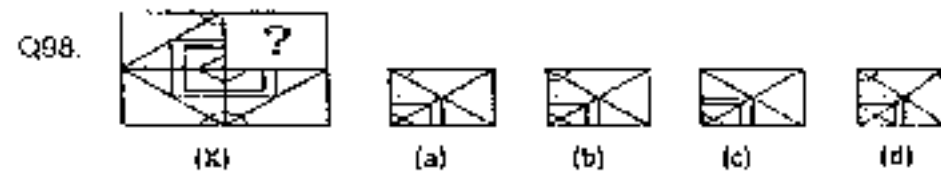
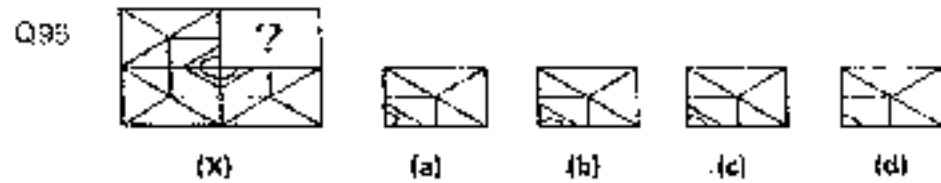

AFCAT VII

Instructions for candidates

TIME ALLOTTED: 2 Hrs

1. Total No. of Questions-100. Each Question is of three marks.
2. One mark will be deducted for every wrong answer.
3. Do not write or mark on the Question Paper.
4. Question Paper to be returned before leaving the Exam Hall.

Read the following passage carefully and answer the questions given below:

We shall go on to the end, we shall fight in France, we shall fight on the seas and oceans, we shall fight with the growing confidence and strength in the air, we shall defend our island whatever the cost may be, we shall fight on the beaches, we shall fight on the landing grounds, we shall fight in the fields and in the streets, we shall fight in the hills. We shall never surrender, and even if this island or a large part of it were subjugated and starving, then our empire beyond the seas would carry on the struggle, until the New World steps forth to the rescue and the liberation of the Old.

- Q1. On the basis of the passage which of the following statements may be said to be correct?
- (a) The speaker is encouraging his men for the conquest of France
 - (b) The speaker is an aggressive and maniacal war-monger
 - (c) The speaker is not satisfied with the conquest of the island
 - (d) The speaker is a patriot urging the defence of his motherland
- Q2. The speaker in the passage wants to go on fighting because:-
- (a) He is a raving lunatic
 - (b) He is in a state of utter despair
 - (c) He expects help from other quarters
 - (d) He is the leader of a suicide squad
- Q3. Which of the following pair of the phrases helps best to bring out the intention of the speaker?
- (a) "Go on to the end", "shall never surrender"
 - (b) "Growing confidence", "subjugated and starving"
 - (c) "Subjugated and starving", "fighting on the landing ground"
 - (d) "Fighting in the streets", "subjugated and starving"
- Q4. The passage consists of repetitive patterns in syntax and vocabulary. The effect of this style is that it -
- (a) Reveals the speaker's defects in giving a speech
 - (b) Produces the impression of bad poetry
 - (c) Conveys the speaker's helpless situation
 - (d) Reinforces the speaker's basic intention
- Q5. The tone of the speaker is:-
- (a) Pleading and urging
 - (b) Inspiring and encouraging
 - (c) Discouraging and gloomy
 - (d) Menacing and bullying

In each of the following, choose the word most similar in meaning to the word given in capitals.

- Q6. 'MEDDLE'
- (a) Disregard (b) Overlook (c) Interfere (d) Free

Continued 2....

- Q7 'ABJURE'
 (a) Renounce (b) Run off secretly (c) Abide (d) Discuss
- Q8 'ESTRANGE'
 (a) Endange: (b) To become puzzling (c) Miscalculate (d) Alienate

In each of the following, choose the word which is nearly opposite in meaning to the word given in capitals

- Q9 'DEROGATORY'
 (a) Conferred (b) Immoderate (c) Praising (d) Private
- Q10 'WANE'
 (a) Wider (b) Poor (c) Swell (d) Tight

In each of the following questions, find out which part has an error

- Q11 The police had re-arrested the thief (a) before he got into my house (b) last night (c)
- Q12 The man who (a) they thought to be (b) a gentleman turned out (c) to be a rogue (d)
- Q13 I told him on his face (a) that he could not hope (b) to pass the stringent (c) medical examination of the Services Selection Board. (d)
- Q14 Mohan is one of those boys (a) who has expressed (b) willingness for joining (c) the educational tour (d)
- Q15 I may spend (a) this summer vacations (b) with one of my friends (c) in the back waters of Kerala. (d)

Pick up the most effective word from the given words to fill in the blanks to make the sentence meaningfully complete

- Q16 According to the weather _____ it is going to be cloudy today
 (a) Announcement (b) Indication (c) Prediction (d) Forecast
- Q17 The villagers _____ the murder of their leader by burning the police van
 (a) Protested (b) Avenged (c) Mourned (d) Consolated
- Q18 While on a routine flight, the aircraft was hit by a missile and _____ into flames
 (a) Fired (b) Burst (c) Caught (d) Engulfed
- Q19 Hari got the company car for a _____ price as he was the senior most employee in the company
 (a) Reduced (b) Discounted (c) Fixed (d) Nominal
- Q20 The unruly behavior of the soldiers _____ their commander.
 (a) Clashed (b) Aggrieved (c) Incensed (d) Impeached
- Q21 Who accorded the title 'Mahatma' to Mahatma?
 (a) Sardar Patel (b) Nehru (c) Sarojini Naidu (d) Rajendra Prasad Tagore
- Q22 The Non-Co-operation Movement started in which year?
 (a) 1900 (b) 1921 (c) 1940 (d) 1930
- Q23 During the Middle Ages education was confined only to
 (a) Kshatriyas (b) Brahmins (c) Peasants (d) Soldiers
- Q24 Who among the following was responsible for the spread of Buddhism in Sri Lanka?
 (a) Ashoka (b) Mahaveera (c) Paravanthi (d) Chandra Gupta Maurya
- Q25 The elements which have low value of ionization potential are strong
 (a) Oxidising agents (b) Reducing agents
 (c) Corrosive and flouting agents depending upon the redox potential (d) None of these

- Q.26. Wayne Rooney, the famous footballer, hails from which country?
 (a) Italy (b) Brazil (c) Argentina (d) England
- Q.27. The official song 'WakaWaka' of FIFA World Cup held in the year 2010 at South Africa was sung by which popular singer?
 (a) Madonna (b) Destiny Child (c) Shakira (d) Rihanna
- Q.28. In the year 2011, the ace badminton player Saina Nehwal was honoured with which sports award?
 (a) Dronacharya award (b) Rajiv Gandhi Khel Rtna award
 (c) Arjun award (d) None of these
- Q.29. Term 'Visible Horizon' in astronomy is defined as -
 (a) The circle of contact of the earth and the cone of visual rays passing through the meridian of the place.
 (b) The circle of contact of the earth and the cone of visual rays not passing through the meridian of the place.
 (c) The circle of contact of the earth and the cone of visual rays passing through the point of observation.
 (d) The circle of contact of the earth and the cone of visual rays not passing through the point of observation.
- Q.30. NREGA stands for -
 (a) National Revenue Engagement Guarantee Association
 (b) National Revenue Employment Guarantee Act
 (c) National Rural Employment Guarantee Association
 (d) National Rural Employment Guarantee Act
- Q.31. River Satluj originates from -
 (a) Northern slopes of the Kailash range (b) Spring at Verinaq
 (c) Rakas Lake (d) Amarkantak plateau.
- Q.32. Limonite ore is the ore of which metal?
 (a) Iron (b) Aluminium (c) Zinc (d) Cobalt
- Q.33. Black revolution relates to which of the following?
 (a) Self-dependence in foodgrains production (b) Self-dependence in milk production
 (c) Self-dependence in petroleum/crude oil (d) None of these
- Q.34. Kargur is the unmanned bomber aircraft of -
 (a) Iraq (b) Iran (c) Turkey (d) Pakistan
- Q.35. Who is the author of book 'Keeping the Faith: Memoirs of a Parliamentarian'?
 (a) David Darda (b) Raja Shekhsah (c) Ragnav Bani (d) Somnath Chatterjee
- Q.36. _____ is a thyroid hormone which controls the balance of calcium in the body
 (a) Calcitonin (b) Thyroxine (c) Calmodulin (d) all of these
- Q.37. The cell wall in plants is interrupted by narrow pores carrying fine strands of cytoplasm which interlink the contents of the cells. These strands are called -
 (a) Plasmahole (b) Microvilli (c) Plasmodesmata (d) Plasmalemma
- Q.38. Who is the cricketer bestowed with an honorary commission in the Territorial Army?
 (a) Sachin Tendulkar (b) Kapil Dev (c) Virendra Sehwa (d) Harbhajan Singh
- Q.39. The transport phenomenon occurs only in _____ state of a gas and is _____
 (a) Non-equilibrium, irreversible (b) Non-equilibrium, reversible
 (c) equilibrium, irreversible (d) equilibrium, reversible

- Q40. Which of the following compounds form nitrites with nitrous acid?
 (a) Primary amines (b) Secondary amines
 (c) Tertiary amines (d) All of these
- Q41. The number whose square is equal to the difference of the squares of 37 and 23 is
 (a) 45.09 (b) 28.58 (c) 47.09 (d) 26
- Q42. The average age of 8 men is increased by 4 years when one of them whose age is 30 years is replaced by a new man. What is the age of new man?
 (a) 55 Years (b) 52 Years (c) 42 Years (d) 64 Years
- Q43. A vessel, full of water, weighs 24 Kg. When the vessel is 1/4 full it weighs 9 kg. Find the weight of empty vessel
 (a) 4 Kg (b) 5 Kg (c) 8 kg (d) 3 kg
- Q44. If $a-b = 4$ and $ac = 45$ find the value of a^2-b^2 .
 (a) 604 (b) 376 (c) 253 (d) 159
- Q45. If $a/(a-b) = 5/21$, what is $(a+b)/(a-b)$ equal to?
 (a) 13/9 (b) 23/11 (c) 14/5 (d) 21/9
- Q46. $\frac{(798+579)^2 - (798-579)^2}{(798 \times 579)} = ?$
 (a) 2 (b) 6 (c) 4 (d) 8
- Q47. A man's average monthly expenditure for the first four months of the year was ₹ 231.25. For the next five months the average monthly expenditure was ₹ 22.75 more than what it was during the first four months. If the person spent ₹ 605 in all during the remaining three months of the year, find what percentage of his annual income of ₹ 3500 did he save in the year?
 (a) 10% (b) 15% (c) 20% (d) 25%
- Q48. The average age of students of a class is 15.8 years. The average age of boys in the class is 16.4 years and that of the girls is 15.4 years. The ratio of the number of boys to the number of girls in the class is:
 (a) 1:2 (b) 2:3 (c) 3:4 (d) 3:5
- Q49. 18 buckets of water fill a tank when the capacity of each bucket is 6 litres. How many buckets will be needed to fill the same tank if the capacity of the bucket is 12 litres?
 (a) 12 (b) 13.5
 (c) 24 (d) can not be determined due to insufficient data
- Q50. Srinivasan invests two equal amounts in two banks giving 8% and 12% rate of interest respectively. At the end of year the interest earned is Rs 1500. Find the sum invested in each.
 (a) ₹ 8500 (b) ₹ 15000 (c) ₹ 7500 (d) ₹ 17,000
- Q51. The simple interest accrued on a sum of money at the end of four years is 1/5th of its principal. What is the rate of interest per annum?
 (a) 4% (b) 5% (c) 6% (d) Inadequate data
- Q52. A sum of ₹ 2600 is lent out into two parts: one at 9% and another at 7%. If the total annual income is ₹ 206, find the money lent at 7%.
 (a) ₹ 1400 (b) ₹ 900 (c) ₹ 1800 (d) ₹ 1200
- Q53. In an election between two candidates, 70% of the voters cast their votes, out of which 2% of the votes were declared invalid. A candidate got 7203 votes which was 60% of the total valid votes. Find the total number of voters enrolled in that election.
 (a) 18350 (b) 17500 (c) 17000 (d) 1200

- Q54. If the price of kerosene be raised by 11% find by how much percent a house holder must reduce his consumption of kerosene so as not to increase his expenditure?
 (a) 11% (b) 9.9% (c) 11.09% (d) 8.25%
- Q55. 75 pupils from a school appeared for an examination and 80% of them passed. Another school entered 10 more pupils than the first school and five pupils less than the first school passed. The pass % of in the second school was:-
 (a) 75% (b) 84% (c) 72% (d) 64.7%
- Q56. Divide ₹ 80 in the proportion of 3:6:7
 (a) ₹ 10, ₹ 35, ₹ 40 (b) ₹ 15, ₹ 30, ₹ 35
 (c) ₹ 15, ₹ 35, ₹ 30 (d) ₹ 10, ₹ 40, ₹ 35
- Q57. Calculate the amount on ₹ 1575 for 2 years at 4% per annum, compounded yearly.
 (a) ₹ 676 (b) ₹ 776 (c) ₹ 1778 (d) ₹ 2028
- Q58. If x varies as y and $x = 8$ when $y = 15$ then the value of x when $y = 10$ is -
 (a) 5 (b) $15/8$ (c) $8/15$ (d) $15/3$
- Q59. In a mixture of 60 litres, the ratio of milk and water is 2:1. What amount of water must be added to make the ratio of milk and water as 1:2?
 (a) 42 Litres (b) 56 Litres (c) 60 Litres (d) 77 Litres
- Q60. A sum of ₹ 10,000 is lent partly at 6% and the remaining at 10% p.a. If the yearly interest on the average is 9.2%, the money lent at 10% is -
 (a) ₹ 8000 (b) ₹ 3500 (c) ₹ 5000 (d) ₹ 2000

Direction:- Choose the word which is least like the other words in the group

- Q61. (a) Garo (b) Khasi (c) Kangra (d) Jayantia
 Q62. (a) Virgo (b) Pisces (c) Cancer (d) Orion
 Q63. (a) Shoulder (b) Foot (c) Finger (d) Elbow
 Q64. (a) Canoe (b) Dingy (c) Yacht (d) Igloo
 Q65. (a) Inn (b) Club (c) Motel (d) Hostel

Directions:- The following questions consist of two words that have a certain relationship to each other, followed by four alternatives. Select the best alternative that has the same relationship as the original pair of words.





- Q66. Liquor : Drink
 (a) Bread : Butter (b) Tea : Beverage
 (c) Sniff : Inhale (d) Water : Sip
- Q67. Evaporation : Cloud
 (a) Mountain : Snow (b) Book : Pages
 (c) Pressure : Atmosphere (d) Tension : Breakdown
- Q68. Barrel : Vial
 (a) Book : Pamphlet (b) Book : Reader
 (c) Brochure : Compiler (d) Length : Height
- Q69. Cream : Cosmetics
 (a) Tiger : Forest (b) Mountain : Valley
 (c) Magazine : Editor (d) Teak : Wood
- Q70. Carnivore : Herbivore
 (a) Flesh : Plant (b) Horse : Lion
 (c) Camel : Giraffe (d) Animal : Bird

Direction: Three words in bold letters are given in each question, which have something in common among themselves. Out of the four given alternatives, choose the most appropriate description about these three words.

- Q71. **Hamlet** : **Macbeth** : **Faust**
 (a) They were Princes (b) They are plays by Shakespear.
 (c) They are characters from various dramas (d) They were romantic heroes

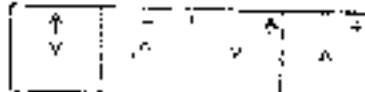
- Q72. **Vesuvius : Etna : Kilimanjaro**
 (a) These are sites of volcanoes. (b) These are island countries.
 (c) These are hills of Italy (d) These lie in polar region
- Q73. **Knot : Watt : Fathom**
 (a) The terms are used by sailors (b) The terms are used for casting dictionary
 (c) The terms are connected with rope (d) They are units of measurement.
- Q74. **Baruni : Digboi : Anikeshwar**
 (a) They are famous for oil fields. (b) They are famous religious places
 (c) They are tourist places of South India (d) They are famous for handicrafts
- Q75. **Knight : Rook : Bishop**
 (a) These are missionaries. (b) These are churchmen
 (c) These are chessmen (d) These are ranks of military
- Q76. **Abhi Bhattacharya : Utpal Dutt : Satyajit Ray**
 (a) They are character actors. (b) They are directors of Bengali movies
 (c) They are famous poets and writers. (d) These personalities belong to Bengal
- Q77. **Voodoo : Sorcery : Necromancy**
 (a) They are ancient arts found in sculptures.
 (b) They are terms connected with black magic
 (c) They are ancient scripts.
 (d) They are means of communication of pre-historic age.
- Q78. **Rourkela : Bokaro : Durgapur**
 (a) They are steel plants (b) They have coal mines
 (c) They have atomic power plants (d) They are on the sea coast
- Q79. **Spinach : Fenugreek : Celery**
 (a) These are cactus plants (c) These are wild plants
 (c) These are wild flowers (d) These are leafy vegetables
- Q80. **Yeast : Ghazib : Kabir**
 (a) They were social reformers (c) They were famous poets.
 (c) They were saints (d) They were yoga instructors

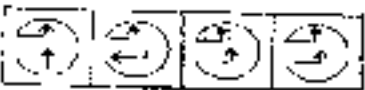
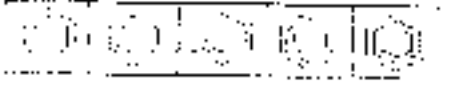
Direction: There are two sets of figures namely the Problem figures containing five figures 1, 2, 3, 4, 5 and answer figures (a), (b), (c), (d). You have to select one figure from the Answer figures which will continue the same series as given in the Problem figures.

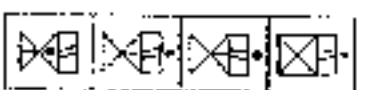
- Q81.  
 (1) (2) (3) (4) (5) (a) (b) (c) (d)
- Q82.  
 (1) (2) (3) (4) (5) (a) (b) (c) (d)
- Q83.  
 (1) (2) (3) (4) (5) (a) (b) (c) (d)
- Q84.  
 (1) (2) (3) (4) (5) (a) (b) (c) (d)

Continued.

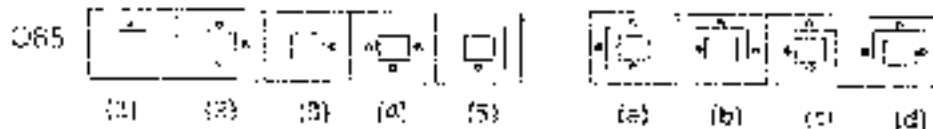

Direction: The following situations involve a cluster of three or more geometrical figures, having one or more dots placed at any point inside the cluster. This cluster is followed by a set of four alternative figures each composed of a cluster of the same type of figures. Now, for each dot we have to observe the region in which it is enclosed i.e. in which of the geometrical figure this region is common.

From amongst the figures marked (a), (b), (c) and (d), select the figure which satisfies the same conditions of placement of the dot as in fig. (X).

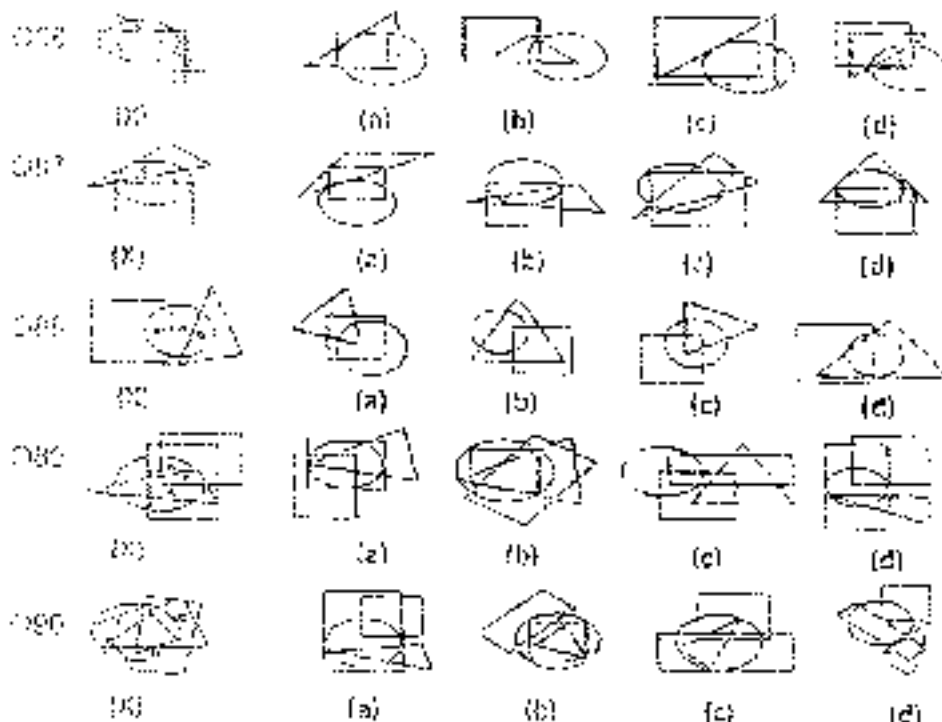

Direction: In this portion, a figure is given as an original figure (X) followed by four alternative figures. The original figure is embedded or hidden in one of the answer figures (a, b, c & d). Select the alternative that carries the correct figure which clearly shows the embedded portion of the original figure.

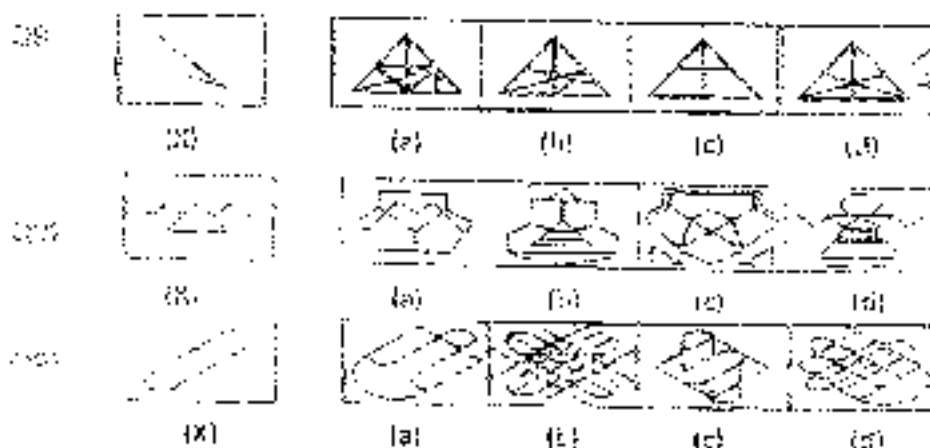

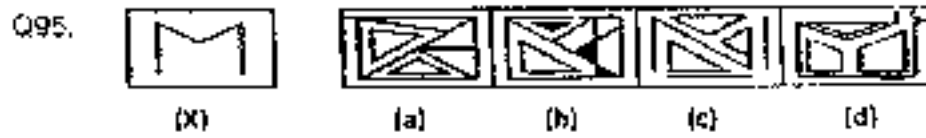
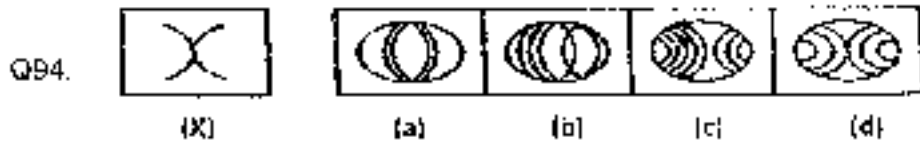

Direction: In each of the following questions, a part of the figure is missing. Find out from the given options (a), (b), (c) or (d), the right figure to fit in the missing figure (X).

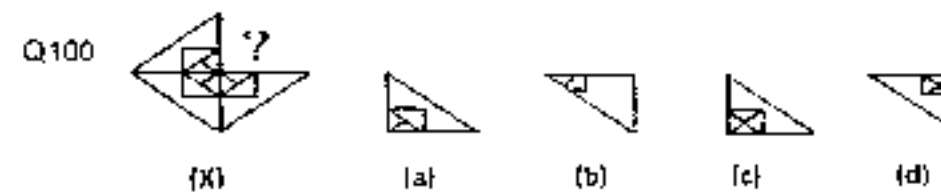
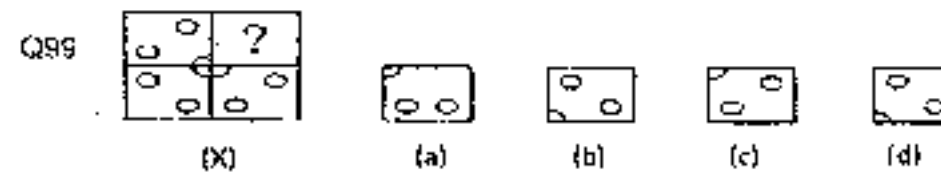
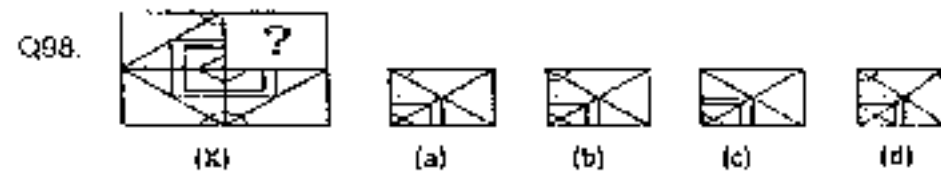
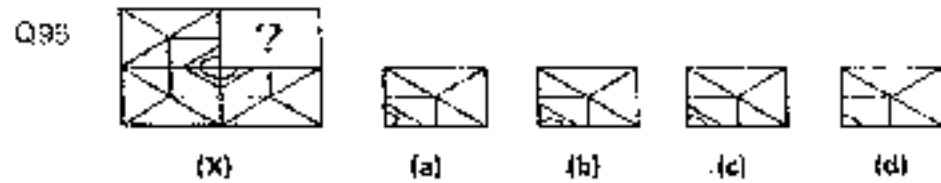

Instructions for candidates **TOTAL MARKS - 300** **TIME ALLOTTED - 2 HRS.**

1. Total No. of Questions-100. Each Question is of three marks.
 2. One mark will be deducted for every wrong answer.
 3. Do not write or mark on the Question Paper.
 4. Question Paper to be returned before leaving the Exam Hall.
-

Read the following passage carefully and answer the questions given below it.

Educational planning should aim at meeting the educational needs of the entire population of all age groups. While the traditional structure of education as a three layer hierarchy from the primary stage to the university represents the core, we should not overlook the periphery which is equally important. Under modern conditions, workers need to rewind, or renew their enthusiasm, or strike out in a new direction, or improve their skills as much as any university professor. The retired and the aged have their needs as well. Educational planning, in other words, should take care of the needs of everyone.

Our structure of education have been built up on the assumption that there is a terminal point to education. The basic defect has become all the more harmful today. A UNESCO report entitled 'Learning to Be' prepared by Edgar Faure and others in 1973 asserts that the education of children must prepare the future adult for various forms of self-learning. A viable education system of the future should consist of modules with different kind of functions serving a diversity of constituents. And performance, not the period of study, should be the basis for credentials. The writing is already on the wall.

In view of the fact that the significance of a commitment of lifelong learning and lifetime education is being discussed only in recent years even in educationally advanced countries, the possibility of the idea becoming an integral part of educational thinking seems to be a far cry. For, to move in that direction means so much more than some simple rearrangement of the present organisation of education. But a good beginning can be made by developing Open University programmes for older learners of different categories and introducing extension services in the conventional colleges and schools. Also, these institutions should learn to cooperate with numerous community organisations such as libraries, museums, municipal recreational programmes, health services etc.

- Q1. What is the main thrust of the author?
 - (a) Traditional systems should be strengthened
 - (b) Formal education is more important than non-formal.
 - (c) One should never cease to learn
 - (d) It is impossible to meet the needs of everyone.
 - Q2. What should be the major characteristic of the future educational system?
 - (a) Different modules with same function
 - (b) Same module for different groups.
 - (c) No modules but standard compulsory programme for all
 - (d) None of the above
 - Q3. According to the author, what measures should open university adopt to meet modern conditions?
 - (a) Develop various programmes for adult learners.
 - (b) Open more colleges on traditional lines
 - (c) Cater to the needs of those who represent 'core'.
 - (d) Primary education should be under the control of open universities.
 - Q4. In the context of the passage, what is the meaning of the sentence "The writing is already on the wall"?
 - (a) Everything is uncertain now-a-days
 - (b) Changes have already taken place.
 - (c) The signs of change are already visible
 - (d) You cannot change the future.
-

In each of the following questions, find out which part of the sentence has an error. If there is no mistake, the answer is (d) "No error".

- Q5. It was a year since / I received any letter / from my sister / No error
 (a) (b) (c) (d)
- Q6. His family members may arrive / at any moment / by car / No error
 (a) (b) (c) (d)
- Q7. He went to office / but returned back / home immediately / No error
 (a) (b) (c) (d)
- Q8. The two brothers amicably divided / their parents' property / among them / No error
 (a) (b) (c) (d)
- Q9. To attain a high academic standard / in his college / Sund worked hard / since morning till night / No error
 (a) (b) (c) (d)

Pick out the most effective word from the given words to fill in the blank to make the sentence meaningfully complete.

- Q10. Mohini is an independent and innovative thinker, therefore it is best to grant her a good deal of _____ with regard to the direction of her research
 (a) leverage (b) interest (c) assistance (d) money
- Q11. The _____ of meat in your refrigerator does not necessarily indicate that you are a vegetarian.
 (a) presence (b) absence (c) amount (d) colour
- Q12. Due to the rise of new media technology, many people predict newspapers will soon be _____
 (a) obsolete (b) ubiquitous (c) commonplace (d) widespread
- Q13. Attention to detail is the _____ of a fine craftsman
 (a) hallmark (b) stamp (c) authenticity (d) show
- Q14. Although the two sisters are twins, they look somewhat _____
 (a) alike (b) unique (c) different (d) related

In each of the following choose the word most similar in meaning to the word given in capitals.

- Q15. VENERATE
 (a) Reject (b) Remove (c) Love (d) Respect
- Q16. VACILLATE
 (a) Waver (b) Disintegrate (c) Relegate (d) Salvage
- Q17. FELICITY
 (a) Zeal (b) Excitement (c) Happiness (d) Expertise

Pick out the word that is most nearly the opposite in meaning to the word given in capitals.

- Q18. HYSTERIA
 (a) Disease (b) Ceremony (c) Serenity (d) Frenzy
- Q19. ABSTAIN
 (a) Indulge (b) Demiss (c) Repel (d) Acquire
- Q20. SPONTANEOUS

Choose the correct answer.

- Q21. The famous Grand Trunk (GT) Road from Peshawar to Kolkata was built by -
 (a) Akbar (b) Ashok (c) Sher Shah Suri (d) Chandragupta
- Q22. The Ashoka Pillar whose Lion Capital (Carving) was adopted by the Government of India as National Emblem is situated at -
 (a) Varanasi (b) Fun (c) Prayag (d) Sarnath
- Q23. The Preamble of the Constitution of India was prepared by -
 (a) Members of Constituent Assembly (b) BR Ambedkar
 (c) Jawaharlal Nehru (d) Dr Radhakrishnan
- Q24. The two great revolutionaries who threw a bomb in Legislative Assembly were -
 (a) Bhagat Singh & BK Dull
 (b) Bhagat Singh & Chandrashekhar Azad
 (c) Chandrashekhar Azad & Bismil
 (d) Bhagat Singh & Ashfaq Ullah Khan
- Q25. 'Duckworth Lewis Rule' is used in the game of -
 (a) Lawn Tennis (b) Cricket (c) Basketball (d) Rugby
- Q26. Dronacharya award is given for outstanding contribution in the field of -
 (a) Sports (b) Sarv Shiksha Abhyasan
 (c) Anganwadi (d) Music
- Q27. Who was the first Indian woman to climb Mount Everest?
 (a) Junko Tabei (b) Bachendri Pal
 (c) Dada Banerjee (d) Sarantacha Gheno
- Q28. The first Olympic Games were held in 1896 at -
 (a) Rome (b) Athens (c) Paris (d) London
- Q29. India tops the world in production of -
 (a) Aluminium (b) Copper (c) Chromite (d) Mica
- Q30. DPT vaccine does not give protection to a child from -
 (a) Tetanus (b) Polio
 (c) Diphtheria (d) Whooping Cough
- Q31. What will be the colour of a red rose when it is seen through green glass?
 (a) White (b) Black (c) Pink (d) Brown
- Q32. Which one of the following is the exclusive power of the Lok Sabha?
 (a) To introduce Money Bill.
 (b) To ratify declaration of Emergency.
 (c) To impeach the President
 (d) To pass No Confidence Motion against Council of Ministers.
- Q33. Indigenously built supersonic cruise missile is known as -
 (a) BrahMos (b) Prithvi (c) Nag (d) Astra
- Q34. Which one of the following crops enriches nitrogen content in the soil?
 (a) Pea (b) Sunflower (c) Potato (d) Wheat
- Q35. Which of the following periodical winds blowing from sea to land cause summer monsoon in India?
 (a) East West (b) North East (c) South West (d) South East

- Q36. India's permanent research station "Dakshin Gangotri" is situated in the -
 (a) Great Himalayas (b) Indian Ocean
 (c) Arabian Sea (d) Antarctica
- Q37. Which one of the following is the busiest ocean route in the world?
 (a) Indian Ocean (b) Pacific Ocean
 (c) North Atlantic Ocean (d) South Atlantic Ocean
- Q38. Defence Services Staff College is located at -
 (a) Khadakvasala (b) Secunderabad (c) Dehradun (d) Wellington
- Q39. The United Nations Organisation responsible to maintain international peace & security was established on 24 October in the year -
 (a) 1920 (b) 1945 (c) 1939 (d) 1942
- Q40. Who authored the book "Freedom at Midnight" ?
 (a) Salman Rushdie (b) Charles Dickens
 (c) Mahatma Gandhi (d) Larry Collins and Dominique Lapierre
- Q41. The number of girls in a class is five times the number of boys. Which of the following cannot be the total number of children in the class?
 (a) 24 (b) 30 (c) 35 (d) 54
- Q42. Ram went to a shop to buy 60 kg of rice. He bought two varieties of rice which cost him ₹ 4.50 per kg and ₹ 5 per kg. He spent a total of ₹ 240. What was the quantity of the cheaper rice purchased by him?
 (a) 20 Kg (b) 25 Kg (c) 30 Kg (d) None of these
- Q43. A man has ₹ 540 in the denominations of one rupee, five rupee and ten rupee notes. The number of each type of notes are equal. What is the total number of notes he has?
 (a) 60 (b) 150 (c) 90 (d) 120
- Q44. The average of five consecutive odd numbers is 81. What is the difference between highest and lowest number?
 (a) 2 (b) 5 (c) 8 (d) 12
- Q45. Jayesh is twice as old as Vijay and half as old as Suresh. If the sum of Vijay's age and Suresh's age is 88 years what is the age of Jayesh?
 (a) 34 years (b) 36 years (c) 88 years (d) 24 years
- Q46. A cricketer has an average of 30 runs in 14 innings. How many runs should he score in his next innings to achieve an average of 32 runs?
 (a) 85 (b) 80 (c) 55 (d) 50
- Q47. What percentage of profit should be added in the cost price of an item so as to gain a profit of 32% after allowing 5% discount to the customer?
 (a) 45 (b) 40 (c) 52 (d) 48
- Q48. If the manufacturer gains 10%, the wholesale dealer gains 15% and the retailer gains 25%. Find the cost of production of a table. The retail price of table is ₹ 1295 -
 (a) ₹ 800 (b) ₹ 1000 (c) ₹ 950 (d) ₹ 1180
- Q49. A loss of 15% on a shirt gets converted into a profit of 17% when the selling price is increased by ₹ 162. What is the cost price of the shirt?
 (a) ₹ 540 (b) ₹ 450 (c) ₹ 600 (d) ₹ 360
- Q50. In an examination 75% of the total students passed in English and 65% passed in Mathematics while 15% failed in English as well as in Mathematics. If a total of 487 candidates

- Q51. When the price of a product was increased by 15%, the number of items sold was decreased by 20%. What was the net effect?
 (a) 10% gain (b) 6% loss (c) 6% loss (d) 4% gain
- Q52. A mixture of 40 litres of milk and water contains 10% water. How much water should be added to this mixture so that the new mixture contains 20% water?
 (a) 4 litres (b) 5 litres (c) 6.5 litres (d) 7.5 litres
- Q53. The ratio of three numbers is 3:4:5 and the sum of their squares is 1260. The sum of the three numbers is -
 (a) 30 (b) 50 (c) 60 (d) 90
- Q54. The average age of three boys is 25 years and their ages are in the proportion 3:5:7. What is the age of the youngest boy?
 (a) 15 years (b) 18 years (c) 21 years (d) 13 years
- Q55. A man has few hens and cows. If the total number of heads are 46 and the total number of feet are 140, then the number of hens are -
 (a) 22 (b) 25 (c) 24 (d) 26
- Q56. A certain sum of money becomes three times of itself in 20 years at simple interest. In how many years will the initial sum become double at the same rate of simple interest?
 (a) 8 (b) 16 (c) 12 (d) 14
- Q57. Ram borrows ₹ 8000 at 12% p.a. simple interest and Mohan borrows ₹ 9100 at 10% p.a. simple interest. In how many years will their borrowed amounts (debt) be equal?
 (a) 18 (b) 20 (c) 22 (d) 24
- Q58. Reena took a loan of ₹ 1200 with simple interest for a certain number of years. The number of years are same as the interest rate. If she has paid ₹ 432 as interest at the end of the loan period, what was the rate of interest?
 (a) 3% (b) 6% (c) 12% (d) None of these
- Q59. A student was asked to divide a number by 3. But instead of dividing it he multiplied it by 3 and got 297 as the answer. What was the correct answer had he not made the mistake?
 (a) 33 (b) 93 (c) 9.8 (d) 9.9
- Q60. Which of the following fraction is the smallest?
 (a) $9/13$ (b) $17/26$ (c) $28/39$ (d) $33/52$

Each question consist of two words which have a certain relationship to each other, followed by four pairs of related words. Select the pair which has the same relationship.

- Q61. STORY : NOVEL
 (a) Sea : Ocean (b) School : University
 (c) Book : Dictionary (d) Poetry : Drama
- Q62. GRAIN : SALT
 (a) Shard : Pottery (b) Shred : Wood
 (c) Blade : Grass (d) Chip : Glass
- Q63. WAITER : TIP
 (a) Student : Marks (b) Worker : Bonus
 (c) Employee : Wages (d) Clerk : Bribe
- Q64. PAIN : SEDATIVE
 (a) Comfort : Stimulant (b) Grief : Consolation
 (c) Trance : Narcotic (d) Ache : Extraction
- Q65. DIRECT : VOICE
 (a) Direct : Voice (b) Language : Less
 (c) Tongue : Sound (d) Voice : Vibration

- Q66. WAN : COLOUR
 (a) Copulent : Weight (b) Imped : Flavour
 (c) Pallid : Complexion (d) Enigmatic : Puzzle
- Q67. PORK : PIG
 (a) Rooster : Chicken (b) Mutton : Sheep
 (c) Steer : Beef (d) Lobster : Crustacean
- Q68. AFTER : BEFORE
 (a) First : Second (b) Present : Past
 (c) Contemporary : Historic (d) Successor : Predecessor
- Q69. EAST : ORIENT
 (a) North : Polar (b) South : Capricorn
 (c) West : Indian (d) West : Occident
- Q70. DISTANCE : MILE
 (a) Liquid : Litre (b) Bushel : Corn
 (c) Weight : Scale (d) Fame : Television
- Q71. TEN : DECIMAL
 (a) Seven : Septet (b) Four : Quartet
 (c) Two : Binary (d) Five : Quintet
- Q72. MUNDANE : SPIRITUAL
 (a) Common : Ghostly (b) Worldly : Unworldly
 (c) Routine : Novel (d) Secular : Clerical
- Q73. LAWYER : COURT
 (a) Businessman : Market (b) Chemist : Laboratory
 (c) Labourer : Factory (d) Athlete : Olympics
- Q74. ARMY : LOGISTICS
 (a) Business : Strategy (b) Soldier : Students
 (c) War : Logic (d) Team : Individual
- Q75. GRAVITY : PULL
 (a) Iron : Metal (b) North pole : Directions
 (c) Magnetism : Attraction (d) Dust : Desert
- Q76. FILTER : WATER
 (a) Curtail : Activity (b) Expunge : Book
 (c) Edit : Text (d) Censor : Play
- Q77. HOPE : ASPIRES
 (a) Love : Elevates (b) Film : Flair
 (c) Fib : Lie (d) Fake : Ordinary
- Q78. GADGET : PAIN
 (a) Killer : Death (b) Teacher : Pupil
 (c) Injury : Bandage (d) Alcohol : Diploamat
- Q79. SYMPHONY : COMPOSER
 (a) Leonardo : Music (b) Fresco : Painter
 (c) Colours : Artist (d) Art : Appreciation
- Q80. CURATOR : MUSEUM
 (a) Wit : Wisdom (b) Bank : Teller
 (c) Manager : Office (d) Doctor : Patient
- Q81. Which word in each set of four is the odd one out ?
 (a) Look (b) See (c) Watch (d) Face

- Q82. This test requires you to identify the relationship between two words. Shoe is to foot as sock is to -
 (a) wind (b) hand (c) foot (d) leg
- Q83. Relaxed means the same as the opposite of -
 (a) calm (b) angry (c) tense (d) sleep
- Q84. Which number comes next in the series?
 1 4 7 10 13 16
 (a) 17 (b) 19 (c) 21 (d) None of these
- Q85. Which number comes next in this series?
 0 1 3 6 10 15
 (a) 19 (b) 21 (c) 26 (d) 32
- Q86. Look at this series: 36, 34, 30, 28, 24. What number should come next?
 (a) 20 (b) 22 (c) 23 (d) 26
- Q87. Look at this series: 22, 21, 23, 22, 24, 23, ... What number should come next?
 (a) 22 (b) 24 (c) 25 (d) 26
- Q88. Look at this series: 53, 53, 40, 40, 27, 27, ... What number should come next?
 (a) 12 (b) 14 (c) 27 (d) 53
- Q89. Look at this series: 8, 22, 8, 29, 8, ... What number should come next?
 (a) 9 (b) 34 (c) 29 (d) 32
- Q90. Look at this series: 31, 29, 24, 22, 17. What number should come next?
 (a) 15 (b) 14 (c) 13 (d) 12

This set of questions is based upon the continuation of figures in a logical manner. There is a sequence of figures depicting a change step by step. Select one of figure from the four choices shown as (a), (b), (c) & (d) which will continue the sequence.

Q81

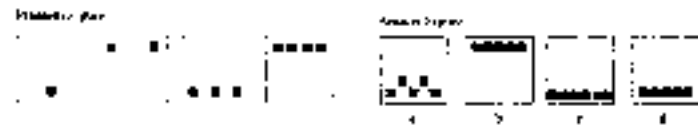

Q82



Q83

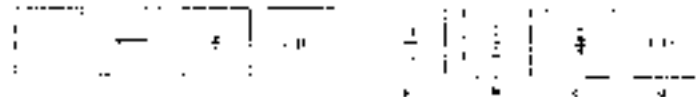

Q84



Which symbol in the Answer Figures completes the sequence in the problem figure –
Q95.

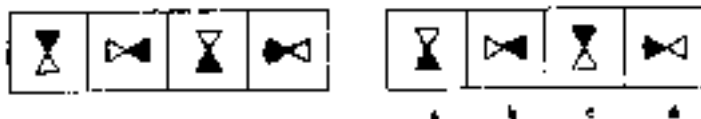

There are certain common characteristics/properties between the two problem figures. Select a figure from amongst the Answer Figures which shows similar characteristics/properties as shown by the problem figures.

Q96.

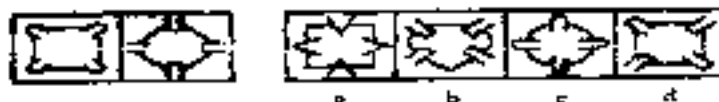

Your task here is to look at the target figure and decide which of the rotated figures below is identical to it. If you do not think any of the figures is the same as the target shape then choose the answer option (a) 'none of these'.

Q97.

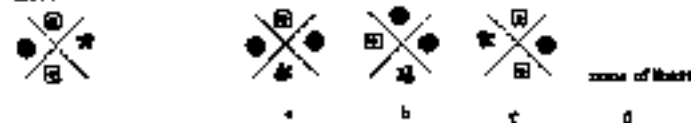

Q98.



Q99.



Your task here is to look at the series of four figures and work out the rule which links them all. Choose which of the three following figures obey that rule and identify the one which does not.

Q100.

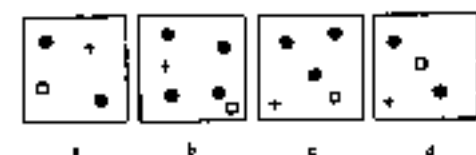

S 16 H 111 19

ANSWER KEYS

AFCAT Model Question Paper-I

1(d)	2(b)	3(d)	4(b)	5(a)	6(d)	7(c)	8(a)	9(d)	10(d)
11(c)	12(c)	13(b)	14(a)	15(b)	16(b)	17(c)	18(c)	19(d)	20(c)
21(c)	22(a)	23(c)	24(c)	25(c)	26(b)	27(a)	28(d)	29(a)	30(c)
31(b)	32(b)	33(d)	34(a)	35(d)	36(c)	37(a)	38(a)	39(a)	40(a)
41(a)	42(d)	43(b)	44(c)	45(c)	46(b)	47(a)	48(d)	49(b)	50(b)
51(b)	52(c)	53(d)	54(c)	55(c)	56(c)	57(d)	58(d)	59(c)	60(b)
61(c)	62(c)	63(a)	64(b)	65(a)	66(d)	67(d)	68(a)	69(c)	70(a)
71(d)	72(c)	73(c)	74(d)	75(c)	76(c)	77(c)	78(c)	79(d)	80(c)
81(d)	82(c)	83(a)	84(b)	85(d)	86(c)	87(c)	88(a)	89(d)	90(c)
91(c)	92(c)	93(a)	94(d)	95(c)	96(a)	97(b)	98(c)	99(c)	100(d)

ANSWER KEYS

AFCAT Model Question Paper-II

1(b)	2(a)	3(d)	4(a)	5(b)	6(a)	7(d)	8(c)	9(a)	10(d)
11(c)	12(b)	13(d)	14(c)	15(b)	16(c)	17(a)	18(b)	19(d)	20(d)
21(b)	22(c)	23(c)	24(c)	25(d)	26(c)	27(c)	28(a)	29(c)	30(b)
31(c)	32(c)	33(a)	34(b)	35(a)	36(c)	37(c)	38(c)	39(d)	40(d)
41(c)	42(b)	43(b)	44(c)	45(d)	46(c)	47(b)	48(b)	49(d)	50(a)
51(d)	52(c)	53(a)	54(a)	55(a)	56(a)	57(a)	58(d)	59(b)	60(c)
61(c)	62(b)	63(a)	64(d)	65(b)	66(d)	67(c)	68(d)	69(c)	70(c)
71(d)	72(c)	73(a)	74(d)	75(a)	76(b)	77(d)	78(d)	79(c)	80(a)
81(d)	82(c)	83(c)	84(c)	85(a)	86(c)	87(d)	88(c)	89(c)	90(c)
91(c)	92(d)	93(a)	94(b)	95(c)	96(a)	97(d)	98(c)	99(c)	100(c)

ANSWER KEYS

AFCAT Model Question Paper-III

1(d)	2(c)	3(b)	4(a)	5(d)	6(d)	7(b)	8(c)	9(c)	10(c)
11(c)	12(d)	13(a)	14(a)	15(a)	16(b)	17(c)	18(d)	19(c)	20(c)
21(d)	22(c)	23(a)	24(b)	25(b)	26(d)	27(d)	28(a)	29(a)	30(a)
31(b)	32(d)	33(c)	34(b)	35(a)	36(d)	37(d)	38(a)	39(b)	40(b)
41(c)	42(a)	43(c)	44(b)	45(b)	46(d)	47(b)	48(c)	49(b)	50(a)
51(d)	52(a)	53(d)	54(b)	55(b)	56(b)	57(c)	58(a)	59(b)	60(b)
61(d)	62(d)	63(c)	64(b)	65(c)	66(b)	67(c)	68(c)	69(d)	70(b)
71(c)	72(a)	73(d)	74(d)	75(b)	76(b)	77(d)	78(c)	79(c)	80(b)
81(a)	82(c)	83(c)	84(d)	85(d)	86(b)	87(c)	88(b)	89(c)	90(d)
91(b)	92(d)	93(d)	94(a)	95(c)	96(a)	97(c)	98(d)	99(b)	100(d)

ANSWER KEYS

AFCAT Model Question Paper-IV

1(d)	2(a)	3(c)	4(c)	5(c)	6(d)	7(d)	8(c)	9(a)	10(b)
11(b)	12(c)	13(b)	14(c)	15(a)	16(a)	17(b)	18(d)	19(c)	20(a)
21(d)	22(d)	23(b)	24(c)	25(c)	26(a)	27(a)	28(d)	29(d)	30(a)
31(d)	32(b)	33(a)	34(a)	35(a)	36(b)	37(b)	38(d)	39(b)	40(c)
41(c)	42(d)	43(a)	44(d)	45(c)	46(d)	47(b)	48(b)	49(b)	50(c)
51(b)	52(d)	53(d)	54(c)	55(b)	56(c)	57(a)	58(d)	59(b)	60(b)
61(b)	62(c)	63(a)	64(b)	65(b)	66(d)	67(b)	68(c)	69(a)	70(d)
71(d)	72(d)	73(a)	74(c)	75(c)	76(b)	77(c)	78(c)	79(d)	80(b)
81(c)	82(d)	83(b)	84(c)	85(b)	86(a)	87(c)	88(b)	89(d)	90(d)
91(b)	92(d)	93(a)	94(c)	95(d)	96(c)	97(b)	98(b)	99(d)	100(c)

**EKT Model Question Paper (Computer
Science)-I**

Instructions for Candidates

Time Allotted: 45Minutes

1. **Total No. of Questions 50. Each Question is of three marks.**
2. **One mark will be deducted for every wrong answer.**
3. **No mark will be deducted for un-attempted questions**
4. **Do not write or make any mark on Question Paper.**

-
- Q1. If the centre of a circle is (-6,8) and it passes through the origin, then equation to its tangent at the origin is
(a) $2y=x$ (b) $4y=3x$ (c) $3y=4x$ (d) $3x+4y=0$
- Q2. The liquid is flowing separately through each of two pipes whose diameters are in the ratio of 2:1, if the ratio of the velocities of flow in the two pipes by 1:2, then the ratio of the amounts of the liquid flowing per sec through the pipe will be
(a) 2:1 (b) 1:1 (c) 4:1 (d) 1:8
- Q3. If $f(x) = x + |x^2 - 8|$ then the derivative of $f(x)$ at $x=3$ is
(a) 6 (b) 7 (c) 8 (d) -8
- Q4. Given $P(A) = 1/4$, $P(B)=1/3$ and $P(A \cup B)= 1/2$. Value of $P(A/B)$ is
(a) $1/4$ (b) $1/3$ (c) $1/6$ (d) $1/7$
- Q5. The angle between two vectors $a = i+2j-k$ and $b=2i+j+k$ is
(a) 30 deg (b) 45 deg (c) 60 deg (d) 90 deg
- Q6. Newton is unit of force. It is the unit in
(a) MKS system (b) CGS system
(c) FPS system (d) None of these
- Q7. A Farad is defined as
(a) stat coulomb /volt (b) coulomb/volt
(c) coulomb x volt (d) stat coulomb x volt
- Q8. Permeance of a magnetic circuit corresponds to the following quantity in electrical circuit
(a) conductivity (b) resistivity (c) conductance (d) resistance
- Q9. Hydrometer is an instrument for measuring
(a) relative humidity (b) pressure of water
(c) volume of liquids (d) specific gravity
- Q10. Radioactivity is a property of
(a) atomic nuclei (b) excited electron
(c) gamma rays (d) ultraviolet light
- Q11. If a plane is parallel to the plane of projection, it appears
(a) true size (b) as a line or edge
(c) foreshortened (d) as an oblique surface
- Q12. How is a J-K Flip Flop made to toggle
(a) $J=0, K=0$ (b) $J=1, K=0$ (c) $J=0, K=1$ (d) $J=1, K=1$
- Q13. No. of flip-flops used in decade counter
(a) 3 (b) 2 (c) 4 (d) None of these

- Q14. The decimal equivalent of the hexadecimal number E5 is
(a) 279 (b) 229 (c) 427 (d) 3000
- Q15. Which part of the computer is used for calculating and comparing?
(a) Disk unit (b) Control unit (c) ALU (d) Modem
- Q16. A CPU's processing power is measured in
(a) IPS (b) CIPS (c) MIPS (d) nano-seconds
- Q17. Which computer memory is volatile?
(a) RAM (b) ROM (c) EPROM (d) PROM
- Q18. The computer code for the interchange of information between terminals is
(a) ASCII (b) BCD (c) EBCDIC (d) All of these
- Q19. Which of the following is not a sequential storage device?
(a) Magnetic disk (b) Magnetic tape (c) Paper tape (d) All of these
- Q20. The data recording area between the blank gaps on magnetic tape is called a/an:
(a) record (b) block (c) field (d) database
- Q21. On a systems flowchart, the online manual keeping of input data is identified by using the
(a) online storage symbol (b) online keyboard symbol
(c) keeping operation symbols (d) manual operation symbols
- Q22. An example of a hierarchical data structure is
(a) array (b) link list (c) tree (d) ring
- Q23. Which of the following system software does the job of merging the records from two files into one?
(a) security software (b) utility program
(c) networking software (d) documentation system
- Q24. Virtual Memory
(a) is a method of memory allocation by which the program is subdivided into equal portions, or pages and core is subdivided into equal portions or blocks
(b) consists of those addresses that may be generated by a processor during execution of a computation
(c) is a method of allocating processor time
(d) allows multiple programs to reside in separate areas of core at the time
- Q25. Which is a permanent database in the general model of compiler?
(a) literal Table (b) identifier Table
(c) terminal Table (d) source code
- Q26. Operating system functions may include
(a) input/output control (b) virtual storage
(c) multi-programming (d) all of these
- Q27. Moving process from main memory to disk is called
(a) scheduling (b) caching (c) swapping (d) spooling

- Q28. In which addressing mode the contents of a register specified in the instruction are first decremented, and these contents are used as the effective address of the operands?
- (a) index addressing (b) indirect addressing
(c) auto increment (d) auto decrement
- Q29. In order to allow only one process to enter its critical section, binary semaphore are initialized to
- (a) 0 (b) 1 (c) 2 (d) 3
- Q30. The outstanding Invoice file should be stored on a Pardon Access Storage Device if
- (a) invoice data entry is on-line
(b) payment recording is done in a batch mode
(c) inquiries concerning payable are to be answered on-line
(d) last record points to the first record
- Q31. In SQL, which command(s) is/are used to enable/disable a database trigger?
- (a) ALTER TRIGGER (b) ALTER DATABASE
(c) ALTER TABLE (d) MODIFY TRIGGER
- Q32. The modify operation is likely to be done after
- (a) Delete (b) Look-up (c) Insert (d) all of these
- Q33. Which of the following is not a logical data-base structure?
- (a) tree (b) relational (c) network (d) chain
- Q34. Which of the following tools is not used in modelling the new system?
- (a) decision tables (b) data dictionary
(c) data-flow diagrams (d) all of these
- Q35. Difference between Decision-Tables and Decision Tree is (are) :
- (a) value to end user
(b) form of representation
(c) one shows the logic while other shows the process
(d) all of the above
- Q36. The reservation system of Indian railways is an example of
- (a) transaction processing system
(b) interactive decision support system
(c) management controls system
(d) expert system
- Q37. The network layer, in reference to the OSI model, provide
- (a) data link procedures that provide for the exchange of data via frames that can be sent and received
(b) the interface between the X.25 network and packet mode device
(c) the virtual circuit interface to packet-switched service
(d) all of the above

- Q38. Which of the following is an important characteristic of LAN?
- (a) application independent interfaces
 - (b) unlimited expansion
 - (c) low cost access for low bandwidth channels
 - (d) parallel transmission
- Q39. Which of the following TCP/IP protocol is used for transferring electronic mail messages from one machine to another?
- (a) FTP
 - (b) SNMP
 - (c) SMTP
 - (d) RPC
- Q40. The slowest transmission speeds are those of
- (a) twisted-pair wire
 - (b) coaxial cable
 - (c) fiber-optic cable
 - (d) microwaves
- Q41. How many digits of the Network User Address are known as the DNIC (Data Network Identification Code)?
- (a) first three
 - (b) first four
 - (c) first five
 - (d) first seven
- Q42. The most flexibility in how devices are wired together is provided by
- (a) bus networks
 - (b) ring networks
 - (c) star networks
 - (d) T-switched networks
- Q43. An FM signal contains intelligence in
- (a) it's frequency variations
 - (b) it's amplitude variations
 - (c) both amplitude and frequency variations
 - (d) none of these
- Q44. In PCM system
- (a) a large bandwidth is required
 - (b) the biggest disadvantage is its incompatibility with TDM
 - (c) companding is used to overcome quantising noise
 - (d) none of the above
- Q45. The all-day efficiency of a transformer depends on
- (a) its copper loss
 - (b) its iron loss
 - (c) both (a) & (b)
 - (d) None of these
- Q46. Slip rings for induction motor are made of
- (a) copper
 - (b) aluminium
 - (c) carbon
 - (d) phosphor bronze
- Q47. One of the characteristic of single phase motor is that it
- (a) is self-starting
 - (b) is not self-starting
 - (c) requires only one winding
 - (d) can rotate in one direction only
- Q48. If the input to a differentiating ckt is saw -tooth wave then output will be-----wave
- (a) Square
 - (b) Rectangular
 - (c) Triangular
 - (d) Saw-tooth
- Q49. Which gate acts as universal gate?
- (a) AND
 - (b) NAND
 - (c) OR
 - (d) EX-OR
- Q50. A 32 bit microprocessor has word length equal to
- (a) 1 byte
 - (b) 2 byte
 - (c) 4 byte
 - (d) 8 byte

**EKT Model Question Paper (Computer
Science)-II**

Instructions for Candidates

Time Allotted: 45 Minutes

1. **Total No. of Questions 50. Each Question is of three marks.**
 2. **One mark will be deducted for every wrong answer.**
 3. **No mark will be deducted for un-attempted questions**
 4. **Do not write or make any mark on Question Paper.**
-

- Q1. If a plane is parallel to the plane of projection, it appears
- (a) true size (b) as a line or edge
(c) foreshortened (d) as an oblique surface
- Q2. How is a J-K Flip Flop made to toggle
- (a) J=0, K=0 (b) J=1, K=0 (c) J=0, K=1 (d) J=1, K=1
- Q3. No. of flip-flops used in decade counter
- (a) 3 (b) 2 (c) 4 (d) None of these
- Q4. The decimal equivalent of the hexadecimal number E5 is
- (a) 279 (b) 229 (c) 427 (d) 3000
- Q5. Which part of the computer is used for calculating and comparing?
- (a) Disk unit (b) Control unit (c) ALU (d) Modem
- Q6. Difference between Decision-Tables and Decision Tree is (are) :
- (a) value to end user
(b) form of representation
(c) one shows the logic while other shows the process
(d) all of the above
- Q7. The reservation system of Indian railways is an example of
- (a) transaction processing system
(b) interactive decision support system
(c) management controls system
(d) expert system
- Q8. The network layer, in reference to the OSI model, provide
- (a) data link procedures that provide for the exchange of data via frames that can be sent and received
(b) the interface between the X.25 network and packet mode device
(c) the virtual circuit interface to packet-switched service
(d) all of the above
- Q9. Which of the following is an important characteristic of LAN?
- (a) application independent interfaces
(b) unlimited expansion
(c) low cost access for low bandwidth channels
(d) parallel transmission

- Q10. Which of the following TCP/IP protocol is used for transferring electronic mail messages from one machine to another?
- (a) FTP (b) SNMP (c) SMTP (d) RPC
- Q11. The slowest transmission speeds are those of
- (a) twisted-pair wire (b) coaxial cable
(c) fiber-optic cable (d) microwaves
- Q12. A CPU's processing power is measured in
- (a) IPS (b) CIPS (c) MIPS (d) nano-seconds
- Q13. Which computer memory is volatile?
- (a) RAM (b) ROM (c) EPROM (d) PROM
- Q14. The computer code for the interchange of information between terminals is
- (a) ASCII (b) BCD (c) EBCDIC (d) All of these
- Q15. Which of the following is not a sequential storage device?
- (a) Magnetic disk (b) Magnetic tape (c) Paper tape (d) All of these
- Q16. The data recording area between the blank gaps on magnetic tape is called a/an:
- (a) record (b) block (c) field (d) database
- Q17. On a systems flowchart, the online manual keeping of input data is identified by using the
- (a) online storage symbol (b) online keyboard symbol
(c) keeping operation symbols (d) manual operation symbols
- Q18. An example of a hierarchical data structure is
- (a) array (b) link list (c) tree (d) ring
- Q19. Which of the following system software does the job of merging the records from two files into one?
- (a) security software (b) utility program
(c) networking software (d) documentation system
- Q20. Virtual Memory
- (a) is a method of memory allocation by which the program is subdivided into equal portions, or pages and core is subdivided into equal portions or blocks
(b) consists of those addresses that may be generated by a processor during execution of a computation
(c) is a method of allocating processor time
(d) allows multiple programs to reside in separate areas of core at the time
- Q21. Which is a permanent database in the general model of compiler?
- (a) literal Table (b) Identifier Table
(c) terminal Table (d) source code
- Q22. Operating system functions may include
- (a) input/output control (b) virtual storage
(c) multi-programming (d) All of these
- Q23. Moving process from main memory to disk is called
- (a) scheduling (b) caching (c) swapping (d) spooling

- Q24. In which addressing mode the contents of a register specified in the instruction are first decremented, and these contents are used as the effective address of the operands?
- (a) index addressing (b) indirect addressing
(c) auto increment (d) auto decrement
- Q25. In order to allow only one process to enter its critical section, binary semaphore are initialized to
- (a) 0 (b) 1 (c) 2 (d) 3
- Q26. The outstanding Invoice file should be stored on a Pardon Access Storage Device if
- (a) invoice data entry is on-line
(b) payment recording is done in a batch mode
(c) inquiries concerning payable are to be answered on-line
(d) last record points to the first record
- Q27. In SQL, which command(s) is/are used to enable/disable a database trigger?
- (a) ALTER TRIGGER (b) ALTER DATABASE
(c) ALTER TABLE (d) MODIFY TRIGGER
- Q28. The modify operation is likely to be done after
- (a) Delete (b) Look-up (c) Insert (d) all of these
- Q29. Which of the following is not a logical data-base structure?
- (a) tree (b) relational (c) network (d) chain
- Q30. Which of the following tools is not used in modelling the new system?
- (a) decision tables (b) data dictionary
(c) data-flow diagrams (d) all of these
- Q31. How many digits of the Network User Address are known as the DNIC (Data Network Identification Code)?
- (a) first three (b) first four (c) first five (d) first seven
- Q32. The most flexibility in how devices are wired together is provided by
- (a) bus networks (b) ring networks (c) star networks (d) T-switched networks
- Q33. An FM signal contains intelligence in
- (a) it's frequency variations (b) it's amplitude variations
(c) both amplitude and frequency variations (d) none of these
- Q34. In PCM system
- (a) a large bandwidth is required
(b) the biggest disadvantage is its incompatibility with TDM
(c) companding is used to overcome quantising noise
(d) none of the above
- Q35. The all-day efficiency of a transformer depends on
- (a) its copper loss (b) its iron loss
(c) both (a) & (b) (d) None of these
- Q36. Slip rings for induction motor are made of
- (a) copper (b) aluminium (c) carbon (d) phosphor bronze

- Q37. One of the characteristic of single phase motor is that it
 (a) is self-starting (b) is not self-starting
 (c) requires only one winding (d) can rotate in one direction only
- Q38. If the input to a differentiating ckt is saw-tooth wave then output will be-----wave
 (a) Square (b) Rectangular (c) Triangular (d) Saw-tooth
- Q39. Which gate acts as universal gate?
 (a) AND (b) NAND (c) OR (d) EX-OR
- Q40. A 32 bit microprocessor has word length equal to
 (a) 1 byte (b) 2 byte (c) 4 byte (d) 8 byte
- Q41. If the centre of a circle is (-6,8) and it passes through the origin, then equation to its tangent at the origin is
 (a) $2y=x$ (b) $4y=3x$ (c) $3y=4x$ (d) $3x+4y=0$
- Q42. The liquid is flowing separately through each of two pipes whose diameters are in the ratio of 2:1, if the ratio of the velocities of flow in the two pipes by 1:2, then the ratio of the amounts of the liquid flowing per sec through the pipe will be
 (a) 2:1 (b) 1:1 (c) 4:1 (d) 1:8
- Q43. If $f(x) = x + |x^2 - 8|$ then the derivative of $f(x)$ at $x=3$ is
 (a) 6 (b) 7 (c) 8 (d) -8
- Q44. Given $P(A) = 1/4$, $P(B)=1/3$ and $P(A \cup B)= 1/2$. Value of $P(A/B)$ is
 (a) $1/4$ (b) $1/3$ (c) $1/6$ (d) $1/7$
- Q45. Permeance of a magnetic circuit corresponds to the following quantity in electrical circuit
 (a) conductivity (b) resistivity (c) conductance (d) resistance
- Q46. Hydrometer is an instrument for measuring
 (a) relative humidity (b) pressure of water
 (c) volume of liquids (d) specific gravity
- Q47. Radioactivity is a property of
 (a) atomic nuclei (b) excited electron
 (c) gamma rays (d) ultraviolet light
- Q48. The angle between two vectors $a = i+2j-k$ and $b=2i+j+k$ is
 (a) 30 deg (b) 45 deg (c) 60 deg (d) 90 deg
- Q49. Newton is unit of force. It is the unit in
 (a) MKS system (b) CGS system
 (c) FPS system (d) None of these
- Q50. A Farad is defined as
 (a) stat coulomb /volt (b) coulomb/volt
 (c) coulomb x volt (d) stat coulomb x volt

EKT Model Question Paper (Electrical & Electronics)-I

Instructions for Candidates

Time Allotted: 45 Minutes

1. Total No. of Questions 50. Each Question is of three marks.
2. One mark will be deducted for every wrong answer.
3. No mark will be deducted for un-attempted questions.
4. Do not write on the Question Paper or make any mark on it.

- Q1. If $x=a(\cos t + t \sin t)$, $y=a(\sin t - t \cos t)$. The value of $\frac{dy}{dx}$ is
(a) $\cos t$ (b) $\sin t$ (c) $\tan t$ (d) $\sec^2 t$
- Q2. The area of three faces of a cuboid are in the ratio 2:3:4 and its volume is 9000 cm^3 . The length of the shortest edge is
(a) 15 cm (b) 30 cm (c) 20 cm (d) 60 cm
- Q3. $\int \frac{dx}{x \log x}$ is equal to
(a) $\log x + x + c$ (b) $\log(\log x) + c$ (c) $x \log x + c$ (d) $\frac{\log x}{x} + c$
- Q4. Tickets numbered 1 to 20 are mixed up and then a ticket is drawn at random. What is the probability that the ticket drawn has a number which is a multiple of 3 or 5?
(a) $\frac{8}{2}$ (b) $\frac{9}{20}$ (c) $\frac{8}{15}$ (d) $\frac{2}{20}$
- Q5. The projection of a vector on another vector is
(a) Scalar (b) Vector
(c) neither vector nor scalar (d) either scalar or vector
- Q6. In MKS system, we measure
(a) mass in kilogram (b) distance in meter
(c) time in second (d) all of these
- Q7. When the separation between two charges is made four times, the force between them
(a) increases four times (b) decreases four times
(c) increases sixteen times (d) decreases sixteen times
- Q8. When a conductor cuts magnetic flux, an emf is induced in the conductor. This is known as
(a) Joule's law (b) Faraday's law
(c) Coulomb's law (d) Ampere's law
- Q9. X-rays are used for the study of crystal structure because
(a) X-rays are completely absorbed by the crystal
(b) the wavelength of X-ray is of the same order of magnitude in the inter-atomic spacing in crystals
(c) the wavelength of X-rays is very small in comparison with the inter-atomic spacing in crystals
(d) the crystals are completely transparent to X-rays

- Q10. A radioactive isotope has a half-life of 10 days. If today there are 125 g of it left, what was its original weight 40 days earlier
(a) 600 g (b) 1000 g (c) 1250 g (d) 2000 g
- Q11. Angles project true size only when the plane containing the angle and plane of projection are
(a) Aligned (b) Adjacent (c) Perpendicular (d) Parallel
- Q12. Tesla is a measure of
(a) magnetic flux density (b) electric flux density
(c) magnetic potential (d) electric potential
- Q13. Admittance is reciprocal of
(a) susceptance (b) impedance (c) reactance (d) conductance
- Q14. _____ is an active filter
(a) RC filter (b) notch filter (c) Butterworth filter (d) band pass filter
- Q15. For transmission line load matching over a range of frequencies, it is best to use a
(a) Balun (b) broadband directional coupler
(c) double stub (d) single stub
- Q16. Emitter follower is used for
(a) reducing the gain (b) increasing the distortion
(c) impedance matching (d) none of these
- Q17. Binary equivalent of $(45)_{10}$ is
(a) $(11101)_2$ (b) $(11110)_2$ (c) $(101101)_2$ (d) $(110101)_2$
- Q18. In Computer memory size K indicates Kilo, which is equal to
(a) 1000 (b) 1024 (c) 100 (d) 10000
- Q19. An astable multivibrator has
(a) no stable state (b) one stable state (c) three stable states (d) two stable states
- Q20. An ideal Op Amp has
(a) infinite input and output impedance
(b) very low input and output impedance
(c) low input impedance and very high output impedance
(d) infinite input impedance and zero output impedance
- Q21. An instruction used to set the carry flag in a computer can be classified as a
(a) data transfer instruction (b) arithmetic instruction
(c) logical instruction (d) program control instruction
- Q22. An FET is a
(a) bipolar semiconductor device (b) unipolar semiconductor device
(c) non semiconductor device (d) both (a) and (c)
- Q23. For Gunn diodes, semiconductor material preferred is
(a) Silicon (b) Germanium (c) Gallium Arsenide (d) all of these
- Q24. In a JFET drain current is maximum when V_{GS} is
(a) zero (b) negative (c) positive (d) equal to V_p

- Q25. The output of Laser is
 (a) Infrared (b) polarised (c) narrow beam (d) coherent
- Q26. As compared to a closed loop system an open loop system is
 (a) more stable as well as more accurate
 (b) less stable as well as less accurate
 (c) more stable but less accurate
 (d) less stable but more accurate
- Q27. Transfer function of a system is used to calculate
 (a) the steady state gain (b) the time constant
 (c) the order of the system (d) the output for a given input
- Q28. In a closed loop control system
 (a) control action depends upon the output and also on the input command
 (b) output signal is fed back to be compared with the reference signal
 (c) the accuracy is better than in the open loop system
 (d) all of the above
- Q29. The difference of the reference input and the actual output signal is called
 (a) error signal (b) controlling signal (c) actuating signal (d) transfer function
- Q30. If the transfer function of a system is $\frac{1}{Ts+1}$, the steady state error to unit step input is
 (a) T (b) zero (c) infinite (d) none of these
- Q31. In a PID controller, the values of proportional, integral and derivative are dependent on
 (a) future, past and present errors respectively
 (b) present, past and future errors respectively
 (c) past, present and future errors respectively
 (d) present, future and past errors respectively
- Q32. The inverse Laplace transform of $\frac{2}{s+1}$ is
 (a) $2(t+1)$ (b) $2e^{-t}$ (c) $2e^t$ (d) e^{-2t}
- Q33. The signal is extended from 96KHz to 100KHz, so the minimum sampling frequency required is
 (a) 8KHz (b) 200KHz (c) 4KHz (d) 100KHz
- Q34. A differentiation circuit has a
 (a) very high time constant (b) very low time constant
 (c) infinite time constant (d) zero time constant
- Q35. Ideally Voltage Standing Wave Ratio (VSWR) should be
 (a) as large as possible (b) as small as possible
 (c) as close to unity as possible (d) infinity
- Q36. Following is/are a property/properties of quantization
 (a) it is an nonlinear process (b) it is an irreversible process
 (c) it maps a larger set of input values to a smaller set (d) all of these

- Q37. Most commonly used filter in SSB generation are
(a) mechanical filters (b) RC filters (c) LC filters (d) low pass filters
- Q38. If the antenna diameter in a radar system is increased by a factor of 4, the maximum range will be increased by a factor of
(a) 2 (b) 4 (c) 8 (d) 16
- Q39. Following type of multiplexing cannot be used for analog signalling
(a) FDM (b) TDM (c) CDM (d) None of these
- Q40. In TDM systems, channel separation is done with the use of
(a) AND gates (b) band-pass filters (c) differentiator circuit (d) integrator circuit
- Q41. Data-link layer of the OSI model specifies
(a) data link procedures that provide for the exchange of data via frames that can be sent and received
(b) the interface between the X.25 network and packet mode device
(c) the virtual circuit interface to packet-switched service
(d) all of the above
- Q42. FDDI is a
(a) ring network (b) star network (c) mesh network (d) bus based network
- Q43. Which of the following TCP/IP protocol allows an application program on one machine to send a datagram to an application program on another machine?
(a) UDP (b) VMTP (c) X.25 (d) SMTP
- Q44. The main difference between synchronous and asynchronous transmission is that
(a) the clocking is derived from the data in synchronous transmission
(b) the clocking is mixed with the data in asynchronous transmission
(c) the pulse height is different
(d) the bandwidth required is different
- Q45. Transducer is a device which
(a) converts one form of power in to the other (b) is similar to transformer
(c) converts one form of energy in to other (d) helps in measuring electricity
- Q46. Principle of hysteresis is not used in
(a) electrical water geyser (b) electrical motor (c) multi-vibrators (d) Schmitt trigger
- Q47. Which of the following motors would not be suitable for use as servomotors?
(a) AC induction motor (b) brushless AC motor
(c) stepper motor (d) permanent magnet DC motor
- Q48. The stator of an induction motor is made of
(a) carbon (b) wood (c) copper stampings (d) silicon steel laminators
- Q49. An ideal DC generator is one that has _____ voltage regulation
(a) low (b) high (c) zero (d) positive
- Q50. Commutator is used in
(a) DC generator (b) AC generator (c) invertors (d) convertors

**EKT Model Question Paper (Electrical &
Electronics)-II**

Instructions for Candidates

Time Allotted: 45 Minutes

- 1. Total No. of Questions 50. Each Question is of three marks.**
 - 2. One mark will be deducted for every wrong answer.**
 - 3. No mark will be deducted for un-attempted questions.**
 - 4. Do not write on the Question Paper or make any mark on it.**
-

- Q1. When a conductor cuts magnetic flux, an emf is induced in the conductor. This is known as
- (a) Joule's law (b) Faraday's law
(c) Coulomb's law (d) Ampere's law
- Q2. X-rays are used for the study of crystal structure because
- (a) X-rays are completely absorbed by the crystal
(b) the wavelength of X-ray is of the same order of magnitude in the inter atomic spacing in crystals
(c) the wavelength of X-rays is very small in comparison with the inter atomic spacing in crystals
(d) the crystals are completely transparent to X-rays
- Q3. Emitter follower is used for
- (a) reducing the gain (b) increasing the distortion
(c) impedance matching (d) none of these
- Q4. Binary equivalent of $(45)_{10}$ is
- (a) $(11101)_2$ (b) $(11110)_2$ (c) $(101101)_2$ (d) $(110101)_2$
- Q5. In Computer memory size K indicates Kilo, which is equal to
- (a) 1000 (b) 1024 (c) 100 (d) 10000
- Q6. An astable multivibrator has
- (a) no stable state (b) one stable state (c) three stable states (d) two stable states
- Q7. An ideal Op Amp has
- (a) infinite input and output impedance
(b) very low input and output impedance
(c) low input impedance and very high output impedance
(d) infinite input impedance and zero output impedance
- Q8. An instruction used to set the carry flag in a computer can be classified as a
- (a) data transfer instruction (b) arithmetic instruction
(c) logical instruction (d) program control instruction
- Q9. An FET is a
- (a) bipolar semiconductor device (b) unipolar semiconductor device
(c) non semiconductor device (d) both (a) and (c)
- Q10. For Gunn diodes, semiconductor material preferred is
- (a) Silicon (b) Germanium (c) Gallium Arsenide (d) all of these

- Q11. In a JFET drain current is maximum when V_{GS} is
 (a) zero (b) negative (c) positive (d) equal to V_p
- Q12. The output of Laser is
 (a) Infrared (b) polarised (c) narrow beam (d) coherent
- Q13. As compared to a closed loop system an open loop system is
 (a) more stable as well as more accurate
 (b) less stable as well as less accurate
 (c) more stable but less accurate
 (d) less stable but more accurate
- Q14. Transfer function of a system is used to calculate
 (a) the steady state gain (b) the time constant
 (c) the order of the system (d) the output for a given input
- Q15. In a closed loop control system
 (a) control action depends upon the output and also on the input command
 (b) output signal is fed back to be compared with the reference signal
 (c) the accuracy is better than in the open loop system
 (d) all of the above
- Q16. The difference of the reference input and the actual output signal is called
 (a) error signal (b) controlling signal (c) actuating signal (d) transfer function
- Q17. If the transfer function of a system is $\frac{1}{Ts+1}$, the steady state error to unit step input is
 (a) T (b) zero (c) infinite (d) none of these
- Q18. In a PID controller, the values of proportional, integral and derivative are dependent on
 (a) future, past and present errors respectively
 (b) present, past and future errors respectively
 (c) past, present and future errors respectively
 (d) present, future and past errors respectively
- Q19. The inverse Laplace transform of $\frac{2}{s+1}$ is
 (a) $2(t+1)$ (b) $2e^{-t}$ (c) $2e^t$ (d) e^{-2t}
- Q20. The signal is extended from 96KHz to 100KHz, so the minimum sampling frequency required is
 (a) 8KHz (b) 200KHz (c) 4KHz (d) 100KHz
- Q21. A differentiation circuit has a
 (a) very high time constant (b) very low time constant
 (c) infinite time constant (d) zero time constant
- Q22. Ideally Voltage Standing Wave Ratio (VSWR) should be
 (a) as large as possible (b) as small as possible
 (c) as close to unity as possible (d) infinity

- Q23. Following is/are a property/properties of quantization
(a) it is an nonlinear process (b) it is an irreversible process
(c) it maps a larger set of input values to a smaller set (d) all of these
- Q24. Most commonly used filter in SSB generation are
(a) mechanical filters (b) RC filters (c) LC filters (d) low pass filters
- Q25. If the antenna diameter in a radar system is increased by a factor of 4, the maximum range will be increased by a factor of
(a) 2 (b) 4 (c) 8 (d) 16
- Q26. Following type of multiplexing cannot be used for analog signalling
(a) FDM (b) TDM (c) CDM (d) None of these
- Q27. In TDM systems, channel separation is done with the use of
(a) AND gates (b) bandpass filters (c) differentiator circuit (d) integrator circuit
- Q28. A radioactive isotope has a half-life of 10 days. If today there are 125 g of it left, what was its original weight 40 days earlier
(a) 600 g (b) 1000 g (c) 1250 g (d) 2000 g
- Q29. Angles project true size only when the plane containing the angle and plane of projection are
(a) Aligned (b) Adjacent (c) Perpendicular (d) Parallel
- Q30. Tesla is a measure of
(a) magnetic flux density (b) electric flux density
(c) magnetic potential (d) electric potential
- Q31. Admittance is reciprocal of
(a) susceptance (b) impedance (c) reactance (d) conductance
- Q32. _____ is an active filter
(a) RC filter (b) notch filter (c) Butterworth filter (d) band pass filter
- Q33. For transmission line load matching over a range of frequencies, it is best to use a
(a) Balun (b) broadband directional coupler
(c) double stub (d) single stub
- Q34. Data-link layer of the OSI model specifies
(a) data link procedures that provide for the exchange of data via frames that can be sent and received
(b) the interface between the X.25 network and packet mode device
(c) the virtual circuit interface to packet-switched service
(d) all of the above
- Q35. FDDI is a
(a) ring network (b) star network (c) mesh network (d) bus based network
- Q36. Which of the following TCP/IP protocol allows an application program on one machine to send a datagram to an application program on another machine?
(a) UDP (b) VMTP (c) X.25 (d) SMTP
- Q37. The main difference between synchronous and asynchronous transmission is that
(a) the clocking is derived from the data in synchronous transmission
(b) the clocking is mixed with the data in asynchronous transmission
(c) the pulse height is different
(d) the bandwidth required is different

- Q38. Transducer is a device which
 (a) converts one form of power in to the other (b) is similar to transformer
 (c) converts one form of energy in to other (d) helps in measuring electricity
- Q39. Principle of hysteresis is not used in
 (a) electrical water geyser (b) electrical motor (c) multi-vibrators (d) Schmitt trigger
- Q40. Which of the following motors would not be suitable for use as servomotors?
 (a) AC induction motor (b) brushless AC motor
 (c) stepper motor (d) permanent magnet DC motor
- Q41. The stator of an induction motor is made of
 (a) carbon (b) wood (c) copper stampings (d) silicon steel laminators
- Q42. An ideal DC generator is one that has _____ voltage regulation
 (a) low (b) high (c) zero (d) positive
- Q43. Commutator is used in
 (a) DC generator (b) AC generator (c) invertors (d) convertors
- Q44. If $x=a(\cos t + t \sin t)$, $y=a(\sin t - t \cos t)$. The value of $\frac{dy}{dx}$ is
 (a) $\cos t$ (b) $\sin t$ (c) $\tan t$ (d) $\sec^2 t$
- Q45. The area of three faces of a cuboid are in the ratio 2:3:4 and its volume is 9000 cm^3 . The length of the shortest edge is
 (a) 15 cm (b) 30 cm (c) 20 cm (d) 60 cm
- Q46. $\int \frac{dx}{x \log x}$ is equal to
 (a) $\log x + x + c$ (b) $\log(\log x) + c$ (c) $x \log x + c$ (d) $\frac{\log x}{x} + c$
- Q47. Tickets numbered 1 to 20 are mixed up and then a ticket is drawn at random. What is the probability that the ticket drawn has a number which is a multiple of 3 or 5?
 (a) $\frac{8}{2}$ (b) $\frac{9}{20}$ (c) $\frac{8}{15}$ (d) $\frac{2}{20}$
- Q48. The projection of a vector on another vector is
 (a) Scalar (b) Vector
 (c) neither vector nor scalar (d) either scalar or vector
- Q49. In MKS system, we measure
 (a) mass in kilogram (b) distance in meter
 (c) time in second (d) all of these
- Q50. When the separation between two charges is made four times, the force between them
 (a) increases four times (b) decreases four times
 (c) increases sixteen times (d) decreases sixteen times

EKT Model Question Paper (Mechanical)-I

Instructions for Candidates**Time Allotted: 45 Minutes**

1. Total number of Questions 50. Each Question is of three marks.
 2. One mark will be deducted for every wrong answer.
 3. No mark will be deducted for un-attempted Question.
 4. Do not write or make any mark on Question Paper.
-

- Q1. If the centre of a circle is $(-6,8)$ and it passes through the origin, then equation to its tangent at the origin is
(a) $2y = x$ (b) $4y = 3x$ (c) $3y = 4x$ (d) $3x + 4y = 0$
- Q2. The liquid is flowing separately through each of two pipes whose diameters are in the ratio of 2:1, if the ratio of the velocities of flow in the two pipes by 1:2, then the ratio of the amounts of the liquid flowing per sec through the pipe will be
(a) 2:1 (b) 1:1 (c) 4:1 (d) 1:8
- Q3. If $f(x) = x + |x^2 - 8|$ then the derivative of $f(x)$ at $x=3$ is
(a) 6 (b) 7 (c) 8 (d) -8
- Q4. Given $P(A) = 1/4$, $P(B)=1/3$ and $P(A \cup B)= 1/2$. Value of $P(A/B)$ is
(a) $1/4$ (b) $1/3$ (c) $1/6$ (d) $1/7$
- Q5. The angle between two vectors $a = i+2j-k$ and $b=2i+j+k$ is
(a) 30 deg (b) 45 deg (c) 60 deg (d) 90 deg
- Q6. Newton is unit of force. It is the unit in
(a) MKS system (b) CGS system (c) FPS system (d) none of these
- Q7. A Farad is defined as
(a) stat coulomb /volt (b) coulomb/volt (c) coulomb x volt (d) stat coulomb x volt
- Q8. Permeance of a magnetic circuit corresponds to the following quantity in electrical circuit
(a) conductivity (b) resistivity (c) conductance (d) resistance
- Q9. Hydrometer is an instrument for measuring
(a) relative humidity (b) pressure of water (c) volume of liquids (d) specific gravity
- Q10. Radioactivity is a property of
(a) atomic nuclei (b) excited electron (c) gamma rays (d) ultraviolet light
- Q11. A bar of length ' L ' meters extends by ' l ' mm under a tensile force of ' P '. The strain produced in the bar is
(a) l/L (b) $0.1 l/L$ (c) $0.01 l/L$ (d) $0.001 l/L$
- Q12. A rod is enclosed centrally in a tube and the assembly is tightened by rigid washers. If the assembly is subjected to a compressive load, then
(a) rod is under compression (b) tube is under compression
(c) both rod and tube are under compression (d) tube is under tension and rod is under compression

- Q13. The shear force and bending moment are zero at the free end of a cantilever beam, if it carries a
(a) point load at the free end (b) point load at the middle of its length
(c) uniformly distributed load over the whole length (d) none of the above
- Q14. The moment of resistance of a balanced reinforced concrete beam is based on the stresses in
(a) steel only (b) concrete only (c) steel and concrete both (d) none of these
- Q15. In a flange coupling, the flanges are coupled together by means of
(a) bolts and nuts (b) studs (c) headless taper bolts (d) none of these
- Q16. A transmission shaft includes
(a) counter shaft (b) line shaft (c) over head shaft (d) all of these
- Q17. A locking device in which the bottom cylindrical portion is recessed to receive the tip of the locking set screw, is called
(a) castle nut (b) jam nut (c) ring nut (d) sawn nut
- Q18. In a venturiflume, the flow takes place at
(a) atmospheric pressure (b) gauge pressure
(c) absolute pressure (d) none of these
- Q19. The total pressure on the top of a closed cylindrical vessel completely filled up with a liquid is
(a) directly proportional to (radius)² (b) inversely proportional to (radius)²
(c) directly proportional to (radius)⁴ (d) inversely proportional to (radius)⁴
- Q20. When the Mach number is more than 6, the flow is called
(a) subsonic flow (b) sonic flow
(c) super-sonic flow (d) hyper-sonic flow
- Q21. The discharge through a convergent mouthpiece is _____ the discharge through an internal mouthpiece of the same diameter and head of water.
(a) equal to (b) one-half (c) three fourth (d) double
- Q22. Which of the following statement is wrong?
(a) The spheroidising process is usually applied to high carbon tool steels which are difficult to machine
(b) In spheroidising process, the cementite in the granular form is produced in the structure of steel
(c) The annealing process causes complete recrystallisation in steels which have been severely cold worked and a new grain structure is formed
(d) none of the above
- Q23. Duplex process of steel making is a combination of
(a) basic bessemer and acid open hearth processes
(b) acid bessemer and basic open hearth processes
(c) acid bessemer and acid open hearth processes
(d) basic bessemer and basic open hearth processes
- Q24. The property of a material necessary for forgings, in stamping images on coins and in ornamental work, is
(a) elasticity (b) plasticity (c) ductility (d) malleability

- Q25. A ladder is resting on a smooth ground and leaning against a rough vertical wall. The force of friction will act
(a) towards the wall at its upper end (b) away from the wall at its upper end
(c) downward at its upper end (d) upward at its upper end
- Q26. The slope on the road surface generally provided on the curves is known as
(a) angle of friction (b) angle of repose (c) angle of banking (d) none of these
- Q27. For any system of coplanar forces, the condition of equilibrium is that the
(a) algebraic sum of the horizontal components of all the forces should be zero
(b) algebraic sum of the vertical components of all the forces should be zero
(c) algebraic sum of moments of all the forces about any point should be zero
(d) all of the above
- Q28. An open cycle gas turbine works on
(a) Carnot cycle (b) Otto cycle (c) Joule's cycle (d) Stirling cycle
- Q29. When the gas is cooled at constant pressure,
(a) its temperature increases but volume decreases
(b) its volume increases but temperature decreases
(c) both temperature and volume increases
(d) both temperature and volume decreases
- Q30. As per Charles' law, the volume of a given mass of a perfect gas varies _____ as its absolute temperature, when the absolute pressure remains constant.
(a) directly (b) indirectly (c) no relation (d) none of the above
- Q31. In an extensive property of a thermodynamic system
(a) extensive heat is transferred (b) extensive work is done
(c) extensive energy is utilised (d) none of these
- Q32. Rotary compressors are used for delivering
(a) small quantities of air at high pressures
(b) large quantities of air at high pressures
(c) small quantities of air at low pressures
(d) large quantities of air at low pressures
- Q33. A rotary compressor is driven by an
(a) electric motor (b) engine (c) either (a) or (b) (d) none of these
- Q34. In a centrifugal compressor, an increase in speed at a given pressure ratio causes
(a) increase in flow (b) decrease in flow
(c) increase in efficiency (d) increase in flow and decrease in efficiency
- Q35. A large clearance Volume in a reciprocating compressor results in
(a) reduced volume flow rate (b) increased volume flow rate
(c) lower suction pressure (d) lower delivery pressure
- Q36. The effect of having excess camber is
(a) excessive steering alignment torque (b) hard steering
(c) too much traction (d) uneven tyre wear
- Q37. If the air-fuel mixture ignites before the spark takes place at spark plug, the condition is called
(a) detonation (b) ignition (c) pre-ignition (d) rumble

- Q38. The diagram which shows the correct crank positions corresponding to the opening and closing of the valves, is known as
 (a) indicator diagram (b) axial force diagram
 (c) valve timing diagram (d) none of these
- Q39. In value engineering, the term value refers to
 (a) manufacturing cost of the product (b) selling price of the product
 (c) total cost of the product (d) utility of the product
- Q40. Production cost refers to prime cost plus
 (a) factory overheads
 (b) factory and administration overheads
 (c) factory, administration and sales overheads
 (d) factory, administration, sales overheads and profit
- Q41. A systematic job improvement sequence will consist of
 (a) motion study (b) time study (c) job enrichment (d) all of these
- Q42. Cast iron during machining produces
 (a) continuous chips (b) discontinuous chips
 (c) continuous chips with built-up-edge (d) none of these
- Q43. A single point thread cutting tool should ideally have
 (a) zero rake angle (b) positive rake angle
 (c) negative rake angle (d) point angle
- Q44. The cutting tool in a milling machine is mounted on
 (a) spindle (b) arbor (c) column (d) knee
- Q45. One quick way to view the entire drawing area is to use the Zoom command by typing _____.
 (a) type Z enter A enter (b) type Z enter E enter
 (c) type SHOWALL enter (d) type ALL enter
- Q46. When setting up a mechanical drawing in AutoCAD the drafter should set the units to _____.
 (a) fractional (b) decimal (c) architectural (d) metric
- Q47. In a class B push-pull amplifier, the transistors are biased slightly above cut-off to avoid
 (a) crossover distortion (b) unusually high efficiency
 (c) negative feedback (d) a low input impedance
- Q48. The depletion-mode MOSFET
 (a) can operate with only positive gate voltages
 (b) can operate with only negative gate voltages
 (c) cannot operate in the ohmic region
 (d) can operate with positive as well as negative gate voltages
- Q49. Ailerons are used to control
 (a) Yaw of aircraft (b) pitch (c) roll (d) None of these
- Q50. Stalling of the aerofoil occurs
 (a) When the angle of attack is beyond critical angle of attack.
 (b) When the angle of attack is less than critical angle of attack.
 (c) Both A and B
 (d) None of the above

EKT Model Question Paper (Mechanical)-II

Instructions for Candidates

Time Allotted: 45 Minutes

1. **Total number of Questions 50. Each Question is of three marks.**
 2. **One mark will be deducted for every wrong answer.**
 3. **No mark will be deducted for un-attempted Question.**
 4. **Do not write or make any mark on Question Paper.**
-

- Q1. One quick way to view the entire drawing area is to use the Zoom command by typing _____.
- (a) type Z enter A enter (b) type Z enter E enter
(c) type SHOWALL enter (d) type ALL enter
- Q2. When setting up a mechanical drawing in AutoCAD the drafter should set the units to _____.
- (a) fractional (b) decimal (c) architectural (d) metric
- Q3. In a class B push-pull amplifier, the transistors are biased slightly above cut-off to avoid
- (a) crossover distortion (b) unusually high efficiency
(c) negative feedback (d) a low input impedance
- Q4. The depletion-mode MOSFET
- (a) can operate with only positive gate voltages
(b) can operate with only negative gate voltages
(c) cannot operate in the ohmic region
(d) can operate with positive as well as negative gate voltages
- Q5. Ailerons are used to control
- (a) Yaw of aircraft (b) pitch (c) roll (d) None of these
- Q6. Stalling of the aerofoil occurs
- (a) When the angle of attack is beyond critical angle of attack.
(b) When the angle of attack is less than critical angle of attack.
(c) Both A and B
(d) None of the above
- Q7. As per Charles' law, the volume of a given mass of a perfect gas varies _____ as its absolute temperature, when the absolute pressure remains constant.
- (a) directly (b) indirectly (c) no relation (d) none of the above
- Q8. In an extensive property of a thermodynamic system
- (a) extensive heat is transferred (b) extensive work is done
(c) extensive energy is utilised (d) none of these
- Q9. Rotary compressors are used for delivering
- (a) small quantities of air at high pressures
(b) large quantities of air at high pressures
(c) small quantities of air at low pressures
(d) large quantities of air at low pressures
- Q10. A rotary compressor is driven by an
- (a) electric motor (b) engine (c) either (a) or (b) (d) none of these

- Q11. In a centrifugal compressor, an increase in speed at a given pressure ratio causes
(a) increase in flow (b) decrease in flow
(c) increase in efficiency (d) increase in flow and decrease in efficiency
- Q12. A large clearance Volume in a reciprocating compressor results in
(a) reduced volume flow rate (b) increased volume flow rate
(c) lower suction pressure (d) lower delivery pressure
- Q13. Newton is unit of force. It is the unit in
(a) MKS system (b) CGS system (c) FPS system (d) none of these
- Q14. A Farad is defined as
(a) stat coulomb /volt (b) coulomb/volt (c) coulomb x volt (d) stat coulomb x volt
- Q15. Permeance of a magnetic circuit corresponds to the following quantity in electrical circuit
(a) conductivity (b) resistivity (c) conductance (d) resistance
- Q16. Hydrometer is an instrument for measuring
(a) relative humidity (b) pressure of water (c) volume of liquids (d) specific gravity
- Q17. Radioactivity is a property of
(a) atomic nuclei (b) excited electron (c) gamma rays (d) ultraviolet light
- Q18. A bar of length ' L ' meters extends by ' l ' mm under a tensile force of ' P '. The strain produced in the bar is
(a) l/L (b) $0.1 l/L$ (c) $0.01 l/L$ (d) $0.001 l/L$
- Q19. A rod is enclosed centrally in a tube and the assembly is tightened by rigid washers. If the assembly is subjected to a compressive load, then
(a) rod is under compression (b) tube is under compression
(c) both rod and tube are under compression (d) tube is under tension and rod is under compression
- Q20. The shear force and bending moment are zero at the free end of a cantilever beam, if it carries a
(a) point load at the free end (b) point load at the middle of its length
(c) uniformly distributed load over the whole length (d) none of the above
- Q21. The moment of resistance of a balanced reinforced concrete beam is based on the stresses in
(a) steel only (b) concrete only (c) steel and concrete both (d) none of these
- Q22. In a flange coupling, the flanges are coupled together by means of
(a) bolts and nuts (b) studs (c) headless taper bolts (d) none of these
- Q23. A transmission shaft includes
(a) counter shaft (b) line shaft (c) over head shaft (d) all of these
- Q24. A locking device in which the bottom cylindrical portion is recessed to receive the tip of the locking set screw, is called
(a) castle nut (b) jam nut (c) ring nut (d) sawn nut
- Q25. In a venturiflume, the flow takes place at
(a) atmospheric pressure (b) gauge pressure
(c) absolute pressure (d) none of these

- Q26. The total pressure on the top of a closed cylindrical vessel completely filled up with a liquid is
(a) directly proportional to (radius)² (b) inversely proportional to (radius)²
(c) directly proportional to (radius)⁴ (d) inversely proportional to (radius)⁴
- Q27. When the Mach number is more than 6, the flow is called
(a) subsonic flow (b) sonic flow
(c) super-sonic flow (d) hyper-sonic flow
- Q28. The discharge through a convergent mouthpiece is _____ the discharge through an internal mouthpiece of the same diameter and head of water.
(a) equal to (b) one-half (c) three fourth (d) double
- Q29. Which of the following statement is wrong?
(a) The spheroidising process is usually applied to high carbon tool steels which are difficult to machine
(b) In spheroidising process, the cementite in the granular form is produced in the structure of steel
(c) The annealing process causes complete recrystallisation in steels which have been severely cold worked and a new grain structure is formed
(d) none of the above
- Q30. Duplex process of steel making is a combination of
(a) basic bessemer and acid open hearth processes
(b) acid bessemer and basic open hearth processes
(c) acid bessemer and acid open hearth processes
(d) basic bessemer and basic open hearth processes
- Q31. The property of a material necessary for forgings, in stamping images on coins and in ornamental work, is
(a) elasticity (b) plasticity (c) ductility (d) malleability
- Q32. A ladder is resting on a smooth ground and leaning against a rough vertical wall. The force of friction will act
(a) towards the wall at its upper end (b) away from the wall at its upper end
(c) downward at its upper end (d) upward at its upper end
- Q33. The slope on the road surface generally provided on the curves is known as
(a) angle of friction (b) angle of repose (c) angle of banking (d) none of these
- Q34. For any system of coplanar forces, the condition of equilibrium is that the
(a) algebraic sum of the horizontal components of all the forces should be zero
(b) algebraic sum of the vertical components of all the forces should be zero
(c) algebraic sum of moments of all the forces about any point should be zero
(d) all of the above
- Q35. An open cycle gas turbine works on
(a) Carnot cycle (b) Otto cycle (c) Joule's cycle (d) Stirling cycle
- Q36. When the gas is cooled at constant pressure,
(a) its temperature increases but volume decreases
(b) its volume increases but temperature decreases
(c) both temperature and volume increases
(d) both temperature and volume decreases

- Q37. The effect of having excess camber is
 (a) excessive steering alignment torque (b) hard steering
 (c) too much traction (d) uneven tyre wear
- Q38. If the air-fuel mixture ignites before the spark takes place at spark plug, the condition is called
 (a) detonation (b) ignition (c) pre-ignition (d) rumble
- Q39. The diagram which shows the correct crank positions corresponding to the opening and closing of the valves, is known as
 (a) indicator diagram (b) axial force diagram
 (c) valve timing diagram (d) none of these
- Q40. In value engineering, the term value refers to
 (a) manufacturing cost of the product (b) selling price of the product
 (c) total cost of the product (d) utility of the product
- Q41. Production cost refers to prime cost plus
 (a) factory overheads
 (b) factory and administration overheads
 (c) factory, administration and sales overheads
 (d) factory, administration, sales overheads and profit
- Q42. A systematic job improvement sequence will consist of
 (a) motion study (b) time study (c) job enrichment (d) all of these
- Q43. Cast iron during machining produces
 (a) continuous chips (b) discontinuous chips
 (c) continuous chips with built-up-edge (d) none of these
- Q44. A single point thread cutting tool should ideally have
 (a) zero rake angle (b) positive rake angle
 (c) negative rake angle (d) point angle
- Q45. The cutting tool in a milling machine is mounted on
 (a) spindle (b) arbor (c) column (d) knee
- Q46. If the centre of a circle is $(-6,8)$ and it passes through the origin, then equation to its tangent at the origin is
 (a) $2y = x$ (b) $4y = 3x$ (c) $3y = 4x$ (d) $3x + 4y = 0$
- Q47. The liquid is flowing separately through each of two pipes whose diameters are in the ratio of 2:1, if the ratio of the velocities of flow in the two pipes by 1:2, then the ratio of the amounts of the liquid flowing per sec through the pipe will be
 (a) 2:1 (b) 1:1 (c) 4:1 (d) 1:8
- Q48. If $f(x) = x + |x^2 - 8|$ then the derivative of $f(x)$ at $x=3$ is
 (a) 6 (b) 7 (c) 8 (d) -8
- Q49. Given $P(A) = 1/4$, $P(B)=1/3$ and $P(A \cup B)= 1/2$. Value of $P(A/B)$ is
 (a) $1/4$ (b) $1/3$ (c) $1/6$ (d) $1/7$
- Q50. The angle between two vectors $a = i+2j-k$ and $b=2i+j+k$ is
 (a) 30 deg (b) 45 deg (c) 60 deg (d) 90 deg

ANSWER KEYS: EKT Model Question
Paper (Mechanical)-I

Question Number	Answer	Question Number	Answer
1	B	26	C
2	A	27	D
3	B	28	C
4	A	29	D
5	C	30	A
6	C	31	D
7	B	32	D
8	C	33	C
9	D	34	D
10	A	35	A
11	D	36	D
12	C	37	C
13	C	38	C
14	C	39	D
15	A	40	A
16	D	41	D
17	C	42	B
18	A	43	A
19	C	44	B
20	D	45	A
21	D	46	B
22	D	47	A
23	B	48	D
24	B	49	C
25	D	50	A

**ANSWER KEY: EKT Model Question
Paper (Mechanical)-II**

Question Number	Answer	Question Number	Answer
1	A	26	C
2	B	27	D
3	A	28	D
4	D	29	D
5	C	30	B
6	A	31	B
7	A	32	D
8	D	33	C
9	D	34	D
10	C	35	C
11	D	36	D
12	A	37	D
13	C	38	C
14	B	39	C
15	C	40	D
16	D	41	A
17	A	42	D
18	D	43	B
19	C	44	A
20	C	45	B
21	C	46	B
22	A	47	A
23	D	48	B
24	C	49	A
25	A	50	C

**ANSWER KEYS: EKT Model Question Paper
(Computer Science)-I**

Question Number	Answer	Question Number	Answer
1	B	26	D
2	A	27	C
3	B	28	D
4	A	29	B
5	C	30	C
6	A	31	A
7	D	32	B
8	C	33	D
9	D	34	D
10	A	35	B
11	A	36	A
12	D	37	C
13	C	38	A
14	B	39	C
15	C	40	A
16	C	41	B
17	A	42	A
18	A	43	A
19	A	44	C
20	B	45	C
21	B	46	D
22	C	47	B
23	B	48	B
24	B	49	B
25	C	50	C

ANSWER KEYS: EKT Model Question Paper
(Computer Science)-II

Question Number	Answer	Question Number	Answer
1	A	26	C
2	D	27	A
3	C	28	B
4	B	29	D
5	C	30	D
6	B	31	B
7	A	32	A
8	C	33	A
9	A	34	C
10	C	35	C
11	A	36	D
12	C	37	B
13	A	38	B
14	A	39	B
15	A	40	C
16	B	41	B
17	B	42	A
18	C	43	B
19	B	44	A
20	B	45	C
21	C	46	D
22	D	47	A
23	C	48	C
24	D	49	A
25	B	50	D

ANSWER KEYS: EKT Model Question Paper (Electrical & Electronics)-I

Question Number	Answer	Question Number	Answer
1	C	26	C
2	A	27	D
3	B	28	D
4	B	29	A
5	A	30	B
6	D	31	B
7	D	32	B
8	B	33	B
9	B	34	B
10	D	35	C
11	D	36	D
12	A	37	A
13	B	38	A
14	C	39	B
15	C	40	A
16	C	41	A
17	C	42	A
18	B	43	A
19	A	44	B
20	D	45	C
21	C	46	C
22	B	47	C
23	C	48	D
24	A	49	C
25	D	50	A

ANSWER KEYS: EKT Model Question Paper (Electrical & Electronics)-II

Question Number	Answer	Question Number	Answer
1	B	26	B
2	B	27	A
3	C	28	D
4	C	29	D
5	B	30	A
6	A	31	B
7	D	32	C
8	C	33	C
9	B	34	A
10	C	35	A
11	A	36	A
12	D	37	B
13	C	38	C
14	D	39	C
15	D	40	C
16	A	41	D
17	B	42	C
18	B	43	A
19	B	44	C
20	B	45	A
21	B	46	B
22	C	47	B
23	D	48	A
24	A	49	D
25	A	50	D